ROBE

ROBIN[®] MMX

Spot

ROBIN[®] MMX

Spot Wireless DMX

CRMX[™]

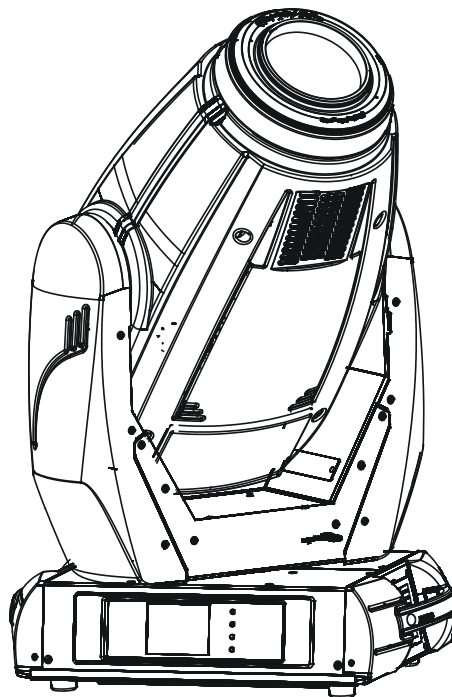

 **ROBIN[®]**
Innovative Technology

USER MANUAL

Version 2.2

ROBE[®] lighting s.r.o. • Czech Republic • www.robe.cz

Robin MMX Spot

Table of contents

1. Safety instructions	3
2. Operating determination	4
3. Fixture exterior view	5
4. Installation	6
4.1 Connection to the mains	6
4.2 Installing the lamp	7
4.3 Lamp adjustment	7
4.4 Replacing rotating gobos	8
4.5 Replacing graphic wheels	9
4.6 Rigging the fixture	10
4.7 DMX-512 connection.....	12
4.8 Ethernet connection	13
5. Remotely controllable functions	15
6. Control menu map	16
7. Control menu	19
7.1 Tab "Address"	20
7.2 Tab "Information"	21
7.3 Tab "Personality"	23
7.4 Tab "Manual Control".....	24
7.5 Tab "Stand-alone"	25
7.6 Tab "Service"	26
7.7 Icon "Lamp menu"	28
8. RDM	28
9. Wireless DMX operation	29
10. Error and information messages	30
11. Technical Specifications	33
12. Maintenance and cleaning	38
13. ChangeLog	38

CAUTION!
Keep this device away from rain and moisture!
Unplug mains lead before opening the housing!

**FOR YOUR OWN SAFETY, PLEASE READ THIS USER MANUAL CAREFULLY
BEFORE YOU INITIAL START - UP!**

1. Safety instructions

Every person involved with installation and maintenance of this device have to:

- be qualified
- follow the instructions of this manual

CAUTION!
Be careful with your operations.
With a high voltage you can suffer
a dangerous electric shock when touching the wires!

This device has left our premises in absolutely perfect condition. In order to maintain this condition and to ensure a safe operation, it is absolutely necessary for the user to follow the safety instructions and warning notes written in this manual.

Important:

The manufacturer will not accept liability for any resulting damages caused by the non-observance of this manual or any unauthorized modification to the device.

Please consider that damages caused by manual modifications to the device are not subject to warranty.

During the operation the housing becomes hot (up to 100°C). Allow the fixture to cool approximately 20 minutes prior to manipulate with it.

Make sure that the available voltage is not higher than stated on the rear panel.

Always plug in the power plug last. Make sure that the power-switch is set to off-position before you connect the device to the mains. The power plug has to be accessible after installing the device.

Make sure that the power-cord is never crimped or damaged by sharp edges. Check the device and the power-cord from time to time.

Always disconnect from the mains, when the device is not in use or before cleaning it. Only handle the power-cord by the plug. Never pull out the plug by tugging the power cord.

This device falls under protection class I. Therefore it is essential to connect the yellow/green conductor to earth.

The electric connection, repairs and servicing must be carried out by a qualified employee.
Do not connect this device to a dimmer pack.

Do not switch the fixture on and off in short intervals as this would reduce the lamp's life.

During the initial start-up some smoke or smell may arise. This is a normal process and does not necessarily mean that the device is defective.

Do not touch the device's housing bare hands during its operation (housing becomes hot)!
For replacement use lamps and fuses of same type and rating only.

CAUTION ! EYE DAMAGES !
Avoid looking directly into the light source
(meant especially for epileptics) !

2. Operating determination

This device is a moving head for creating decorative effects and was designed for indoor use only.

If the device has been exposed to drastic temperature fluctuation (e.g. after transportation), do not switch it on immediately. The arising condensation water might damage your device. Leave the device switched off until it has reached room temperature.

Never run the device without lamp!

Before switching the fixture OFF, turn the lamp OFF and allow the fixture to cool for a while.

Do not shake the device. Avoid brute force when installing or operating the device.

Never lift the fixture by holding it at the projector-head, as the mechanics may be damaged. Always hold the fixture at the transport handles.

When choosing the installation-spot, please make sure that the device is not exposed to extreme heat, moisture or dust. There should not be any cables lying around. You endanger your own and the safety of others!

The minimum distance between light output and the illuminated surface must be more than 5 meters.

Make sure that the area below the installation place is blocked when rigging, derigging or servicing the fixture.

Always fix the fixture with an appropriate safety rope. Fix the safety rope at the correct holes only.

Only operate the fixture after having checked that the housing is firmly closed and all screws are tightly fastened.

The lamp must never be ignited if the objective-lens or any housing-cover is open, as discharge lamps may explode and emit a high ultraviolet radiation, which may cause burns.

The maximum ambient temperature 45°C must never be exceeded.

CAUTION!
***The lens has to be replaced when it is obviously damaged,
so that its function is impaired, e. g. due to cracks or deep scratches!***

Operate the device only after having familiarized with its functions. Do not permit operation by persons not qualified for operating the device. Most damages are the result of unprofessional operation!

CAUTION!
***The lamp has to be replaced when it is damaged
or deformed due to the heat!***

Please use the original packaging if the device is to be transported.

Please consider that unauthorized modifications on the device are forbidden due to safety reasons!

If this device will be operated in any way different to the one described in this manual, the product may suffer damages and the guarantee becomes void. Furthermore, any other operation may lead to dangers like short-circuit, burns, electric shock, burns due to ultraviolet radiation, lamp explosion, crash etc.

3. Fixture exterior view

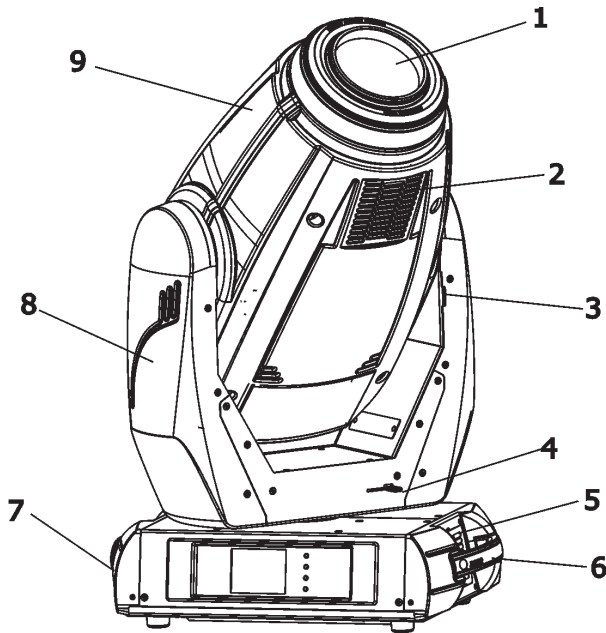

- 1 - Front lens
- 2 - Air filter
- 3 - Tilt lock
- 4 - Pan lock
- 5 - Air filter
- 6 - Arm
- 7 - Base
- 8 - Arm
- 9 - Moving head

The head should be locked for transportation- the tilt lock latch (2) and the pan lock latch (3) have to be in the locked positions. To unlock the head, move these latches to unlock positions before operating the fixture.

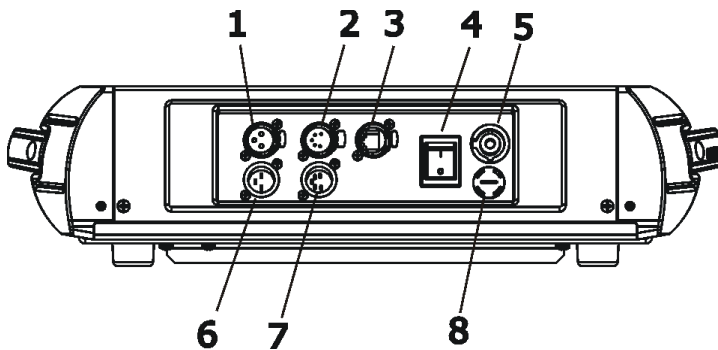

Rear panel of the base:

- 1 - DMX output (3-pin XLR)
- 2 - DMX output (5-pin XLR)
- 3 - Ethernet input (RJ45)
- 4 - Power switch
- 5 - Power input (Neutrik PowerCon)
- 6 - DMX input (3-pin XLR)
- 7 - DMX input (5-pin XLR)
- 8 - Fuse holder

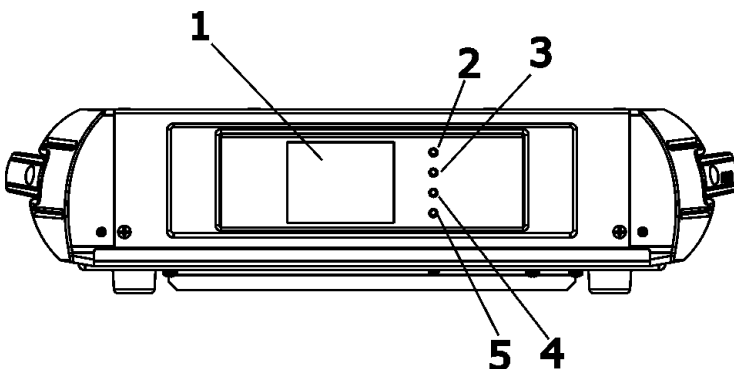

Front panel of the base:

- 1 - QVGA touch screen
- 2 - ESCAPE button
- 3 - NEXT button
- 4 - PREVIOUS button
- 5 - ENTER/DISPLAY ON button

The ENTER/DISPLAY ON button also serves for switching the display on when the fixture is disconnected from the mains.

4. Installation



Fixtures must be installed by a Qualified electrician in accordance with all national and local electrical and construction codes and regulation.

4.1 Connection to the mains

For protection from electric shock, the fixture must be earthed!

The Robin MMX Spot is equipped with auto-switching power supply that automatically adjusts to any 50/60Hz AC power source from 100-240 Volts.

For use with 100-120 V supplies, the main 8 A fuse has to be exchanged for 15 A fuse which is enclosed in the packing.

To install the 15 A fuse:

1. Disconnect the fixture from AC power.
2. Unscrew the fuse holder on the rear panel of the base with a flat-tip screwdriver from the housing (anticlockwise).
3. Remove the 8 A fuse from the fuse holder.
4. Put the 15 A fuse in the fuse holder.
5. Replace the fuse holder in the housing and screw it fully clockwise.

Install a suitable plug on the power cord, note that the cores in the power cord are coloured according to the following table. The earth has to be connected!

If you have any doubts about proper installation, consult a qualified electrician.

Core (EU)	Core (US)	Connection	Plug Terminal Marking
Brown	Black	Live	L
Light blue	White	Neutral	N
Yellow/Green	Green	Earth	

4.2 Installing the lamp

**DANGER ! Install the lamp with the device switched off only.
Unplug from mains before !**

To insert the new lamp.

1. Disconnect the fixture from power and allow it to cool at least 15 minutes.
2. Make sure that the fixture's head is in the position as shown on the picture (notices on the lamp cover are in readable position) .Loosen the two quarter-turn fasteners (1) marked "X,Y" on the lamp cover to open this cover.

3. Holding the lamp by its ceramic base, carefully turn the lamp to the left to loosen the lamp from the lamp holder.

Gently pull the lamp out of the lamp holder

4. Holding the new lamp by its ceramics base, gently insert the lamp to the lamp socket and turn the base to the right. Make sure that the lamp is installed tightly into the lamp socket.

Do not install a lamp with a higher wattage! A lamp like this generates temperatures the device is not designed for. Damages caused by non-observance are not subject to warranty.

Please follow the lamp manufacturer's notes! Do not touch the glass bulb bare hand during the installation!

5. Re-insert the lamp cover and tighten the two quarter-turn fasteners (1).
6. Switch on the fixture.
7. Align the lamp (see instructions below)
8. Reset the "Lamp On Time" and "Lamp Strikes" counters in the menu "Information".

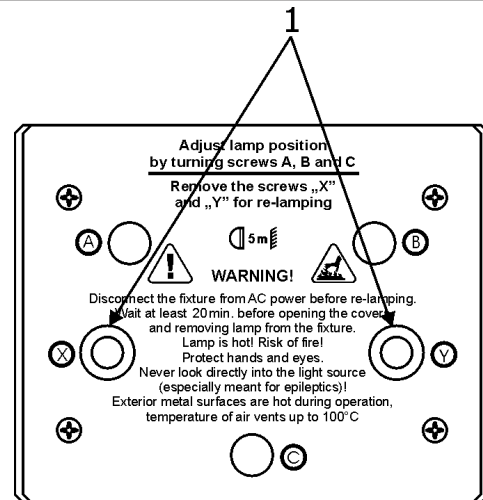

Do not operate this fixture with open lamp cover!

4.3 Lamp adjustment

The lamp holder is aligned at the factory. Due to differences between lamps, the fine adjustment may improve light performance:

To adjust the lamp in the fixture.

1. Switch on the fixture and after its reset turn on the lamp.
2. Go to the "Service" menu and select the item "Adjust Lamp" to project the light beam on the wall.
3. Use items in this menu to focus the light beam and set the item HotSpot at 0 DMX .
4. Turn adjustment screws marked "A, B, C" (2) one after another until you reach a max. light intensity (.
5. Center the hot-spot (the brightest part of the beam) using these 3 adjustment screws (2).

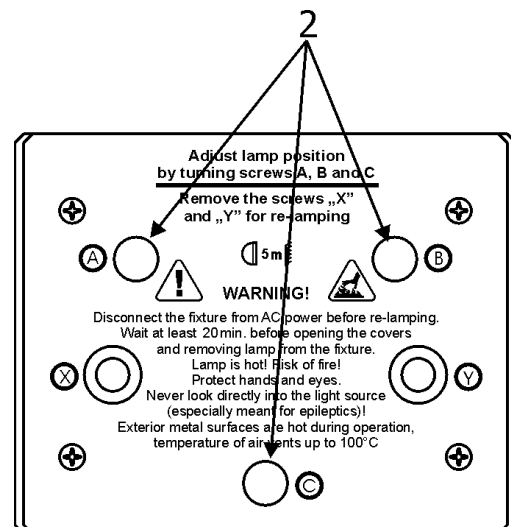

4.4 Replacing rotating gobos

***Install gobos with the device switched off only.
Unplug from mains before!***

To replace rotating gobos.

1. Disconnect the fixture from mains and allow it to cool.
2. Remove the bottom plastic cover of the head by loosening the 4 quarter-turn fasteners on the cover.
3. Gently pull up the gobo holder from the rotation gobo wheel.
4. Remove the spring gobo-lock with an appropriate tool (e.g. small-bladed screwdriver) and remove it.
Do not touch the surface of the pattern of the glass gobo with bare fingers.
5. Remove the original gobo and insert the new one (glazy side towards the lamp). Insert the spring-gobo lock to secure it in the gobo holder.
6. Insert the gobo holder back under the distance slots into rotating gobo wheel.
5. Replace the bottom cover before applying power.

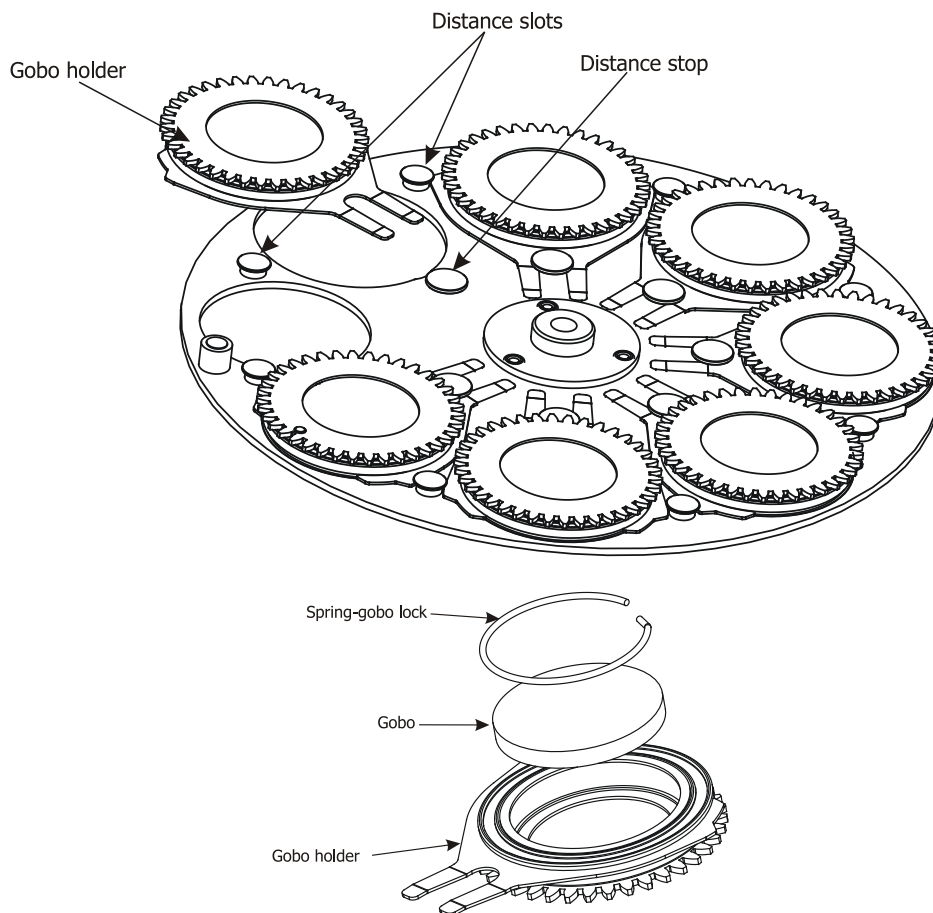

4.5 Replacing graphic wheels

***Install graphic wheels with the device switched off only.
Unplug from mains before!***

The dual graphic wheel consists of two graphic wheels. Both wheels has to be changed at the same time. To replace graphic wheels.

1. Disconnect the fixture from mains and allow it to cool.
2. Remove the bottom plastic cover of the head by loosening the 4 quarter-turn fasteners on the cover.
3. Tilt up the dual graphic wheel.
4. Remove the spring graphic wheel - lock with an appropriate tool (e.g. small-bladed screwdriver) and remove it.
5. Remove the first original graphic wheel and insert the new one (glazy side towards the lamp, black side toward the objective!). Insert the spring-gobo lock to secure it in the graphic wheel holder.
6. Use the same steps to change the second graphic wheel.
5. Put the bottom cover back before applying power.

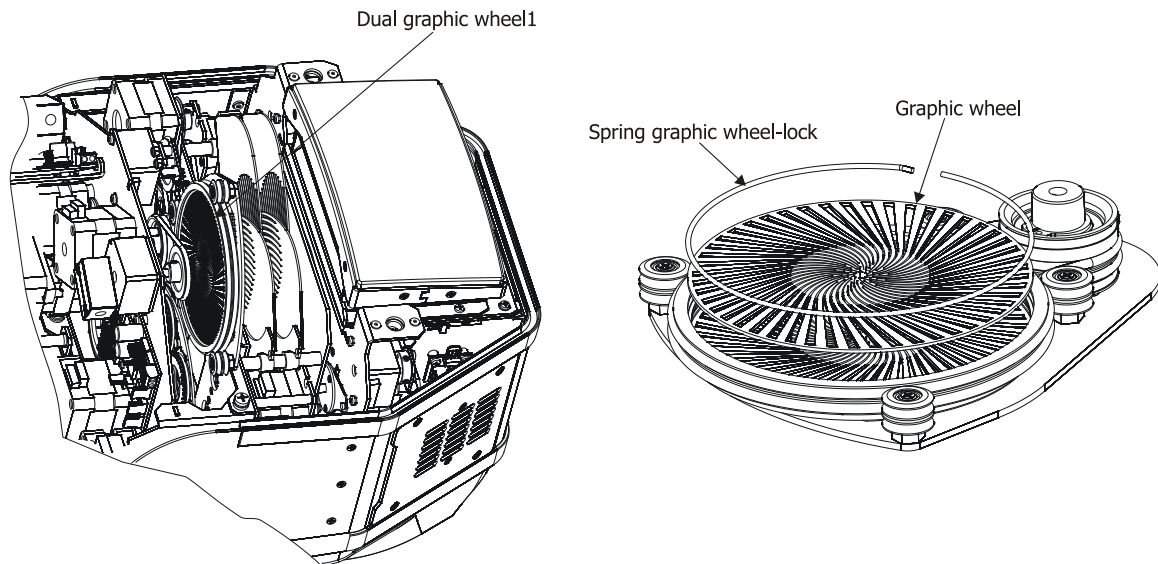

4.6 Rigging the fixture

The installation of the fixture has to be built and constructed in a way that it can hold 10 times the weight for 1 hour without any harming deformation.

The installation must always be secured with a secondary safety attachment, e.g. an appropriate catch net. This secondary safety attachment must be constructed in a way that no part of the installation can fall down if the main attachment fails.

When rigging, derigging or servicing the fixture staying in the area below the installation place, on bridges, under high working places and other endangered areas is forbidden.

The operator has to make sure that safety-relating and machine-technical installations are approved by an expert before taking into operation for the first time and after changes before taking into operation another time.

The operator has to make sure that safety-relating and machine-technical installations are approved by an expert after every four year in the course of an acceptance test.

The operator has to make sure that safety-relating and machine-technical installations are approved by a skilled person once a year.

The projector should be installed outside areas where persons may walk by or be seated.

IMPORTANT! OVERHEAD RIGGING REQUIRES EXTENSIVE EXPERIENCE, including (but not limited to) calculating working load limits, installation material being used, and periodic safety inspection of all installation material and the fixture. If you lack these qualifications, do not attempt the installation yourself, but instead use a professional structural rigger. Improper installation can result in bodily injury or damage to property.

The fixture has to be installed out of the reach of people.

If the fixture shall be lowered from the ceiling or high joists, professional trussing systems have to be used. The fixture must never be fixed swinging freely in the room.

Caution: Fixtures may cause severe injuries when crashing down! If you have doubts concerning the safety of a possible installation, do not install the moving head!

Before rigging make sure that the installation area can hold a minimum point load of 10 times the fixture's weight.

Danger of fire !
When installing the device, make sure there is no highly inflammable material (decoration articles, etc.) in a distance of min. 1 m.

CAUTION!
Use 2 appropriate clamps to rig the fixture on the truss.
Follow the instructions mentioned at the bottom of the base.
Make sure that the device is fixed properly! Ensure that the structure (truss) to which you are attaching the fixtures is secure.

The fixture can be placed directly on the stage floor or rigged in any orientation on a truss without altering its operation characteristics .

For securing a fixture to the truss install a safety wire that can hold at least 10 times the weight of the fixture. Use only safety wire with screw-on carabine. Pull the safety wire through the carrying handles and around the truss as shown on the pictures below.

Note: If the safety wire is too long, whip it several times around the trusses in order to attach the fixture tight. In case of an accident, the way of the falling fixture will be short.

Omega holders positions:

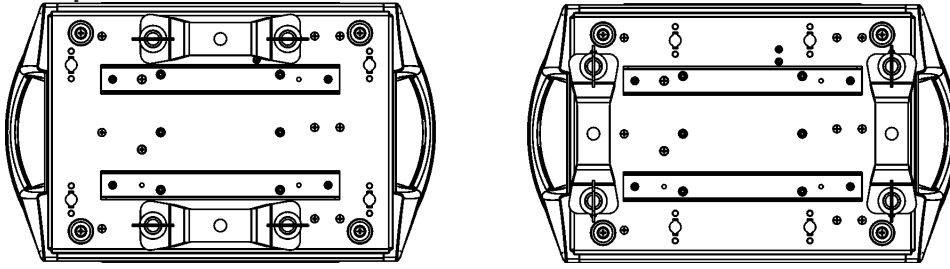

Truss installation

1. Bolt each clamp (1) to the omega holder (3) with M12 bolt and lock nut through the hole in the holder.
2. Fasten the omega holders on the bottom of the base by inserting both quick-lock fasteners (4) into the holes of the base and tighten fully clockwise.
3. Pull the safety wire (2) through the carrying handles (5) and around the truss (6) as shown on the pictures below.

Securing the fixture via one safety wire

Securing the fixture via two safety wires

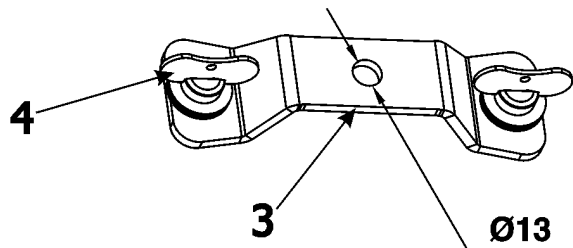
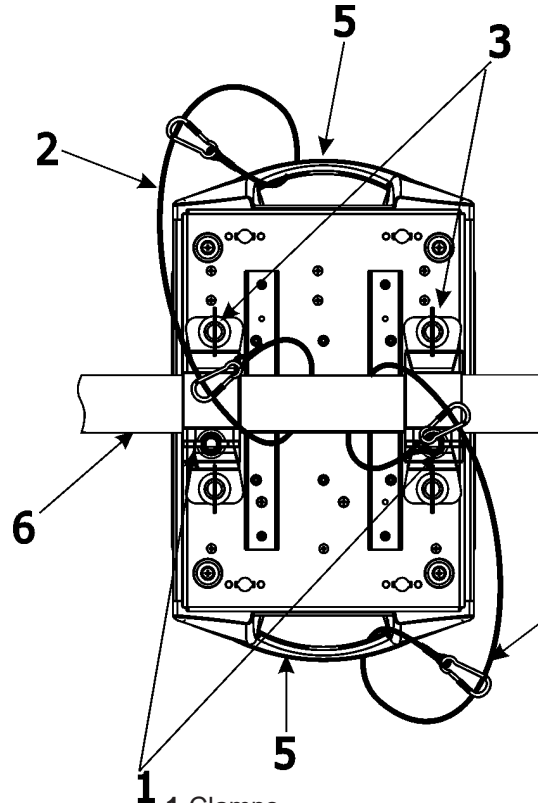
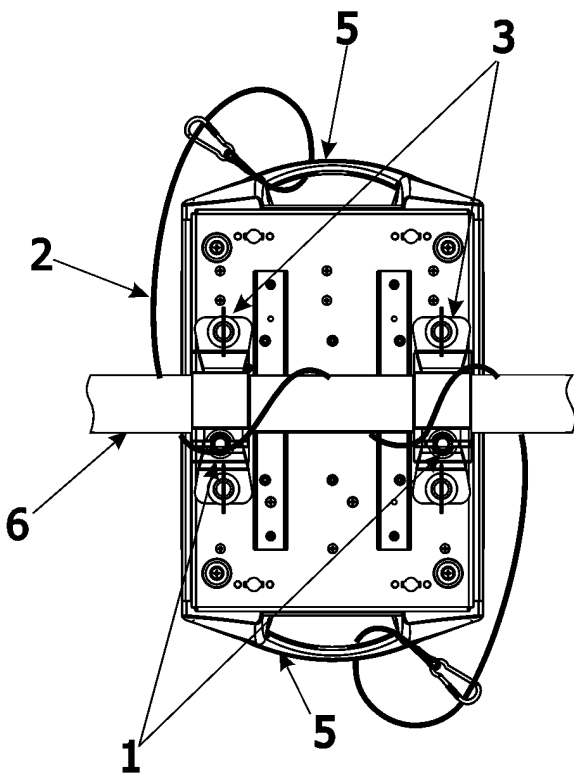

- 1-Clamps
- 2-Safety wire
- 3-Omega holders
- 4-Quick-lock fastener
- 5-Handles
- 6-Truss

**When installing fixtures side-by-side,
avoid illuminating one fixture with another!**

DANGER TO LIFE!
Before taking into operation for the first time, the installation has to be approved by an expert!

4.7 DMX-512 connection

The fixture is equipped with both 3-pin and 5-pin XLR sockets for DMX input and output. The sockets are wired in parallel.

Only use a shielded twisted-pair cable designed for RS-485 and 3-pin or 5-pin XLR-plugs and connectors in order to connect the controller with the fixture or one fixture with another.

DMX - output

XLR mounting-sockets (rear view):

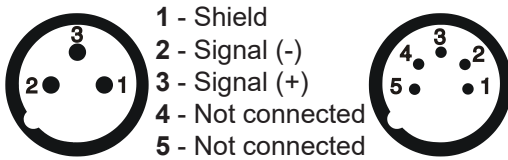

DMX-input

XLR mounting-plugs (rear view):

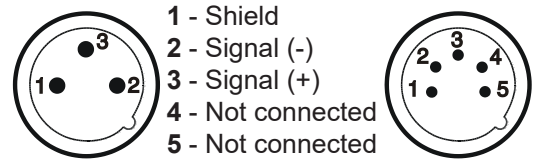

If you are using the standard DMX controllers, you can connect the DMX output of the controller directly with the DMX input of the first fixture in the DMX-chain. If you wish to connect DMX-controllers with other XLR-outputs, you need to use adapter-cables.

Building a serial DMX-chain:

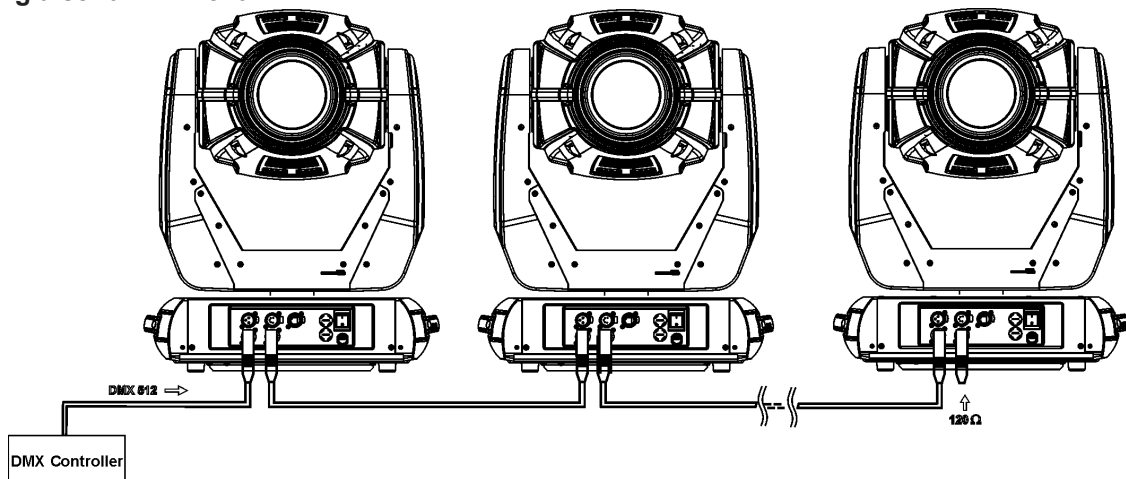

Connect the DMX-output of the first fixture in the DMX-chain with the DMX-input of the next fixture. Always connect one output with the input of the next fixture until all fixtures are connected.

Caution: At the last fixture, the DMX-cable has to be terminated with a terminator. Solder a 120 Ω resistor between Signal (-) and Signal (+) into a 3-pin XLR-plug and plug it in the DMX-output of the last fixture.

4.8 Ethernet connection

The fixtures on a data link are connected to the Ethernet with ArtNet communication protocol. The control software running on your PC (or light console) has to support Art-Net protocol.

Art-Net communication protocol is a 10 Base T Ethernet protocol based on the TCP/IP. Its purpose is to allow transfer of large amounts of DMX 512 data over a wide area using standard network technology.

IP address is the Internet protocol address. The IP uniquely identifies any node (fixture) on a network.

The Universe is a single DMX 512 frame of 512 channels.

The Robin MMX Spot is equipped with 8-pin RJ-45 socket for Ethernet input. Use a network cable category 5 (with four "twisted" wire pairs) and standard RJ-45 plugs in order to connect the fixture to the network.

RJ-45 socket (front view):

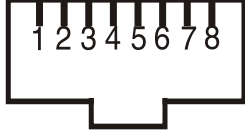

- | | |
|------------------|------------------|
| 1- TD+ | 5- Not connected |
| 2- TD- | 6- RX- |
| 3- RX+ | 7- Not connected |
| 4- Not connected | 8- Not connected |

RJ-45 plug (front view):

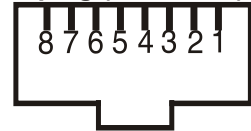

Patch cables that connect fixtures to the hubs or LAN sockets are wired 1:1, that is, pins with the same numbers are connected together:



If only the fixture and the computer are to be interconnected, no hubs or other active components are needed. A cross-cable has to be used:



If the fixture is connected with active Ethernet socket (e.g. switch) the network icon  will appear at the bottom right corner of the screen:

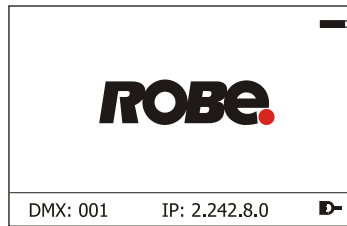

Direct Ethernet operation

Connect the Ethernet inputs of all fixtures with the Ethernet network.

Option "Artnet (gMal or gMA2)" has to be selected from "Ethernet Mode" menu on the fixture.

Set IP address (002.xxx.xxx.xxx / 010.xxx.xxx.xxx) and the Universe.

(DMX address=150)
IP address=002.168.002.004
Universe=1

(DMX address=39)
IP address=002.168.002.003
Universe=1

(DMX address=1)
IP address=002.168.002.002
Universe=1

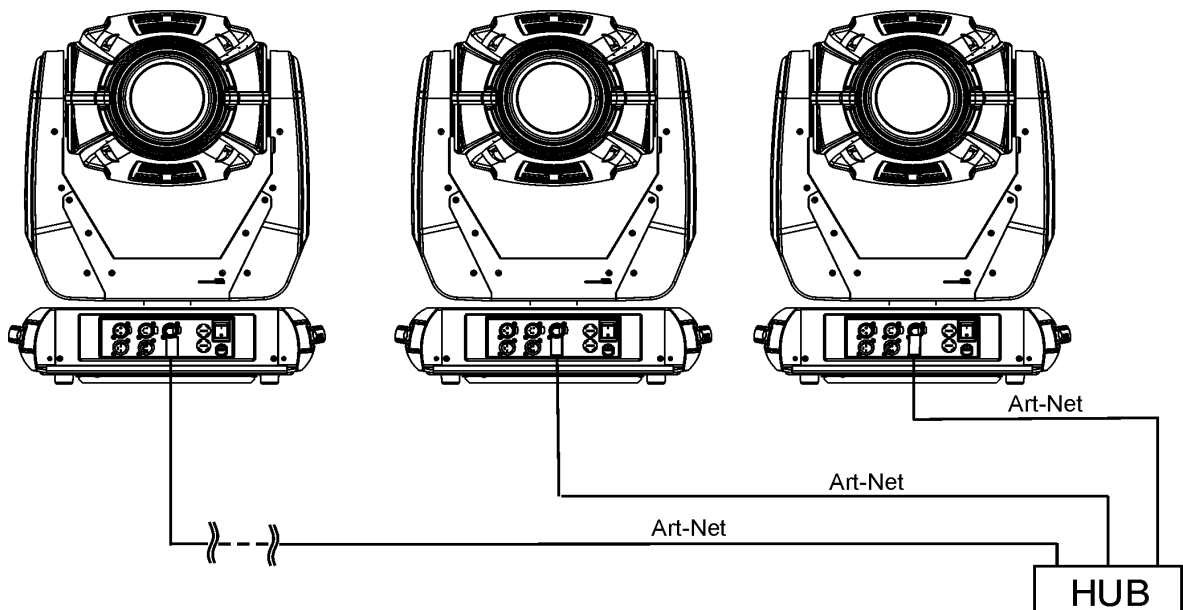

An advised PC setting: IP address: 002.xxx.xxx.xxx / 010.xxx.xxx.xxx (Different from fixture IP addresses)
NET mask: 255.0.0.0

Ethernet / DMX operation

Options "Art2DMX" has to be selected from the "Ethernet Mode" menu on the first fixture (connected to the Ethernet) in the fixture chain, next fixtures have standard DMX setting.

Connect the Ethernet-input of the first fixture in the data chain with the network. Connect the DMX output of this fixture with the input of the next fixture until all fixtures are connected to the DMX chain.

Caution: At the last fixture, the DMX chain has to be terminated with a terminator. Solder a 120 Ω resistor between Signal (-) and Signal (+) into a XLR-plug and connect it in the DMX-output of the last fixture.

Example:

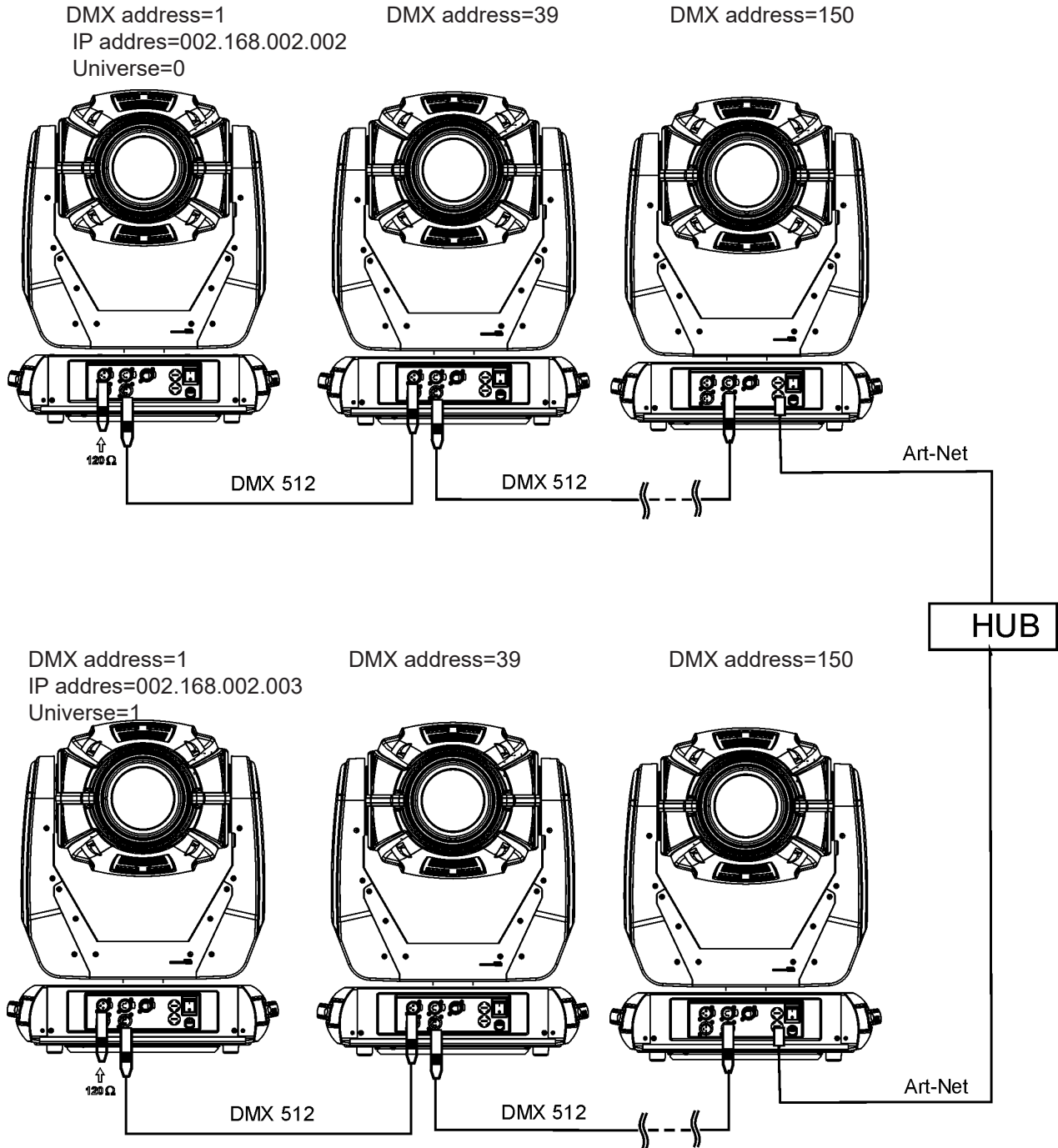

5. Remotely controllable functions

Lamp

The Robin MMX Spot is to be operated with a Philips MSR Platinum 35.

Note: It is also important to note, that the discharge lamp is cold restrike types, that means, that they have to be cold before re-striking. For this reason, you have to wait about 5 minutes after having switched the lamp off before you can switch it on again. If you try to switch on the lamp within 5 minutes after having switched it off, the Robin MMX Spot will store this information and automatically ignite the lamp when the 5 minutes period has expired.

Colour wheel

This wheel contains 6 replaceable 'SLOT&LOCK' dichroic filters + open. The colour wheel can be positioned between two adjacent colours in any position. It is also possible to rotate the colour wheel continuously at different speeds ("Rainbow effect" in both directions).

CMY+CTO colour mixing system

The CMY color mixing system is based on graduated cyan, magenta, and yellow colour filters. A continuous range of colors may be achieved by varying the amount of each filter from 0 to 100%.

Colour temperature correction filter lowers the colour temperature from 6200 K to 3200 K.

Dual graphic wheel

The wheel consists of 2 graphic wheels rotating in both directions with variable speed which create wide spectrum of graphic effects. 30 animation macros in relation to focus channel allows to set many new images.

Rotating gobo wheels

The fixture includes 2 rotating gobo wheels. Each rotating gobo wheel includes 7 gobos rotating in both directions, indexable, replaceable "SLOT&LOCK" glass gobos + open position. Gobo positioning and gobo selection speed is available as well as a gobo-shake function.

Prism

The 3-facet prism rotates in both directions at different speeds, 16 prism/gobo macros are available.

Frost

Frost module provides variable frost for fine frosting.

Iris

Motorized adjustable iris, wide range of variable pulse effects.

Zoom

Motorized zoom unit enables zoom between 8.5° - 42.5° (for a gobo) and 9.8° - 46.5° (for an open hole).

Focus/Autofocus

Motorized focus allows to focus beam from approx. 2 meters to infinity.

Special function autofocus allows to keep focused image during zooming. Use "Focus" channel to focus the image, then select desired distance and effect which you need to focus at channel "Autofocus (priority & distance selection)".

The right value at "Autofocus (priority & distance selection)" channel can be typically in tolerance of + 2 DMX -2DMX. You should try to set value, set focus and check min/max. zoom.

Note: If you use the Autofocus function in the program steps (scenes), there is important to switch off Autofocus before using it in the sequence of program steps.

Step(Scene)	Zoom	Focus	Autofocus
1	255	187	0 (hole)
2	255	181	7 (hole)
3	0	181	7 (hole)
4	0	165	139 (gobo 2)
5	255	165	139 (gobo 2)

If you want to in the step 6 repeat the Autofocus scenes 2-5, you have to go to step 1, after that to the step 2,3...5 If you will go to directly to the step 2, after that to the step 3.... the Autofocus will not work properly because the initial position of the focus module will not be the same as it was in the step 1.

Hot-Spot

Fine movement of the glass reflector allows to change the light intensity from the maximum in the centre of the image to the evenly distributed light intensity.



Dimmer/Shutter unit



Smooth 0 - 100 % dimming is provided by the mechanical dimmer /shutter unit. This unit is also used for strobe effects with variable speed.

6. Control menu map

Default settings=**Bold print**

Tab	Level 1	Level 2	Level 3	Level 4	Level 5	Level 6
Addressing	Settings	DMX Address	001-255			
		Ethernet Settings	Ethernet Mode	Disable		
				ArtNet		
				gMA1		
				gMA2		
				Art2DMX		
			IP Address/Net Mask	Default IP Address		
				Custom IP Address		
				Net Mask		
			ArtNet Universe	0-255		
			MANet settings	MANet/II Universe		
				MANet Session ID		
Information	Fixture Times	Power On Time	Total Hours			
			Resetable Hours			
		Lamp On Time	Total Hours			
			Resetable Hours			
		Lamp Strikes	Total Strikes			
			Resetable Strikes			
		Air Filters	Elapsed Time			
			Alert Period	10-300		
		Fixture Temperatures	Head Temperature	Current		
				Maximum NonRes.		
				Maximum Res.		
			Ambient Temperature	Current		
				Maximum NonRes.		
				Maximum Res.		
			Base Temperature	Current		
				Maximum NonRes.		
				Maximum Res.		
			Lamp Driver Temp. Level	Current		
				Maximum NonRes.		
				Maximum Res.		
		DMX Values	Pan			
			:			
		Dimmer Fine				
	Wireless State*	Signal Quality				
		Unlink Wireless Adapter				
	Software Versions	Display System				
		Module M				
		Module S				
		Module G				
		Module O				
		Module C				
		Module I				
	Product IDs	Mac Address				
		RDM UID				
		RDM Label				
	View Logs	Fixture Errors	Pan Errors			
			:			
			Temp.Sensor Errors			
		Fixture States	Power On			
			Power Off			

Tab	Level 1	Level 2	Level 3	Level 4	Level 5	Level 6
			Lamp On			
			Lamp Off			
		Fixture Position				
		Fixture Temperatures	Head Temperatures			
			Ambient Temperatures			
			Base Temperatures			
Personality	User Mode	User A Settings				
		User B Settings				
		User C Settings				
	DMX Presets	Mode 1				
		Mode 2				
		Mode 3				
		View Selected Preset				
	DMX Input	Wired				
		Wireless				
		Wireless In/XLR Out				
	Pan/Tilt Settings	Pan Reverse	Off, On			
		Tilt Reverse	Off, On			
		Pan/Tilt Feedback	Off, On			
		Pan/Tilt mode	Time			
			Speed			
	Pan/Tilt acceleration	Compatible				
		High				
	Microphone Sensitivity	1-10-20				
	Blackout Settings	Blackout During M.C.	Off, On			
		Blackout while:	Pan/Tilt moving	Off, On		
			Colour Wheel Moving	Off, On		
			Gobo Wheels Moving	Off, On		
			Timeout Blackout	Off, On		
	Init Effect Positions	Pan	0-255			
		:				
		Dimmer Fine	0-255			
	Screen Settings	Display Intensity	1-10			
		Screen Saver Delay	Off-10min.			
		Touchscreen Lock	Off-10min.			
		Recalibrate Touchscreen				
		Display Orientation	Normal			
			Inverted			
			Auto			
	Temperature Unit	°C, °F				
	Fan Mode	Auto				
		High				
		Silent	Fan Noise Level	0-100%		
	CMY Curve	Compatible	On, Off			
		S-curve	On, Off			
	Dimmer Curve	Compatible				
		SYNC				
	Date & Time Settings					
	Autofocus	On, Off				
	Default Settings					
Manual Control	Reset Functions	Reset All Systems				
		Pan/Tilt reset				
		Colour System Reset				
		Gobo System Reset				

Tab	Level 1	Level 2	Level 3	Level 4	Level 5	Level 6
		Dim./Strobe/H.-Spot Res.				
		Zoom/Foc./Fro./Pri. Res.				
		Iris/Dual G. Wheel Reset				
	Preset Effect Control	Pan	Position 1-Position 5			
		:				
		Dimmer	Position 1- Position 5			
	Manual Effect Control	Pan	0-255			
		:				
		Dimmer Fine	0-255			
Stand -Alone	Test Sequences	Dynamic Mode				
		Static Mode	Pan	0-255		
			Tilt	0-255		
			Zoom	0-255		
			Focus	0-255		
			HotSpot	0-255		
	MusicTrigger	Off, On				
	Preset Playback	None				
		Test				
		Prg. 1				
		Prg. 2				
		Prg. 3				
	Play Program	Play Program 1				
		Play Program 2				
		Play Program 3				
	Edit Program	Edit Program 1	Start Step	1-100		
			End Step	1-100		
			Edit Program Steps	Step 1	Pan	0-255
				:	:	
				:	Dimmer Fine	0-255
				:	Step Time	0-25,5 sec.
				Step 100	Pan	0-255
					:	
					Dimmer Fine	0-255
					Step Time	0-25,5 sec.
Service	Adjust DMX Values	Pan	0-255			
		:				
		Dimmer Fine	0-255			
	Adjust Lamp	Pan	0-255			
		:				
		Hot-Spot	0-255			
	Calibrations	Calibrate Effects	Pan	0-255		
			:			
			Dimmer 2	0-255		
		Load Default Calibrations				
	Update Software					
	Hardware Configuration	CMY Module HW Version A,B,C				

* Wireless version only

7. Control menu

The Robin MMX Spot is equipped with the QVGA Robe touch screen with battery backup which allows to set the fixture's behaviour according to your needs, obtain information on its operation, test its various parts and lastly program it, if it has to be used in a stand-alone mode. The fixture's menu can be controlled either by the control buttons or directly by touching the icon.

Control buttons on the front panel:

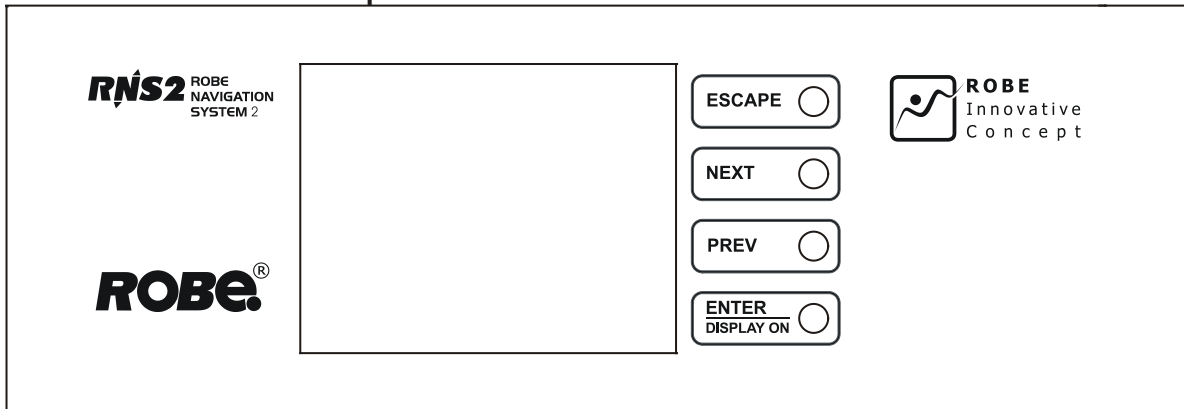

[ESCAPE] button used to leave the menu without saving changes.

[NEXT] , [PREV] buttons for moving between menu items and symbols, adjusting values.

[ENTER/Display On] button used to enter the selected menu (menu item) and to confirm adjusted value.

If the fixture is disconnected from mains, the button switches the touch screen on.

Icons used in the touch screen menu:



- [back arrow] used to move back to the previous screen (menu).



- [up arrow] used to move up on the previous page.



- [down arrow] used to move down on the next page.



- [confirm] used to save adjusted values, to leave menu or to perform desired action.



- [cancel] used to leave menu item without saving changes.



- [confirm+copy] used to save adjusted values and copy them to the next prog. step.



- [warning icon] used to indicate some error which has occurred in the fixture.



- [lamp menu] used to switch on/off the lamp and to set lamp functions.



- [Ethernet] used to indicate Ethernet connected.



- [display turn] used to turn the display by 180°.

The menu page displays icons for each function that you can perform from the touch screen.

After switching the fixture on, the touch screen shows the screen with the ROBE logo:

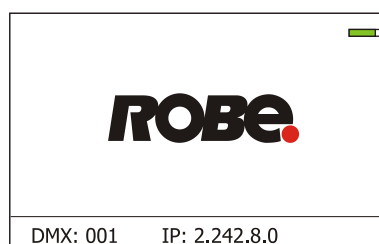

Note: The green icon at the top right corner of the screen indicates the level of the display battery charging. If the whole icon is green, the battery is fully charged while the red icon indicates exhausted battery. The battery charges during fixture operation, its charging lasts cca 6 hours.

We recommend that the fixture should be in operation at least 7 hours per week to keep the battery fully charged. If you switch the fixture on and this screen will not appear till 1 minute, switch the fixture off and on again. If the screen lights, the battery is exhausted. In case the screen still does not light, the battery is faulty.

This is also indicated by an error message "Faulty battery" and if such an error message appears the battery should be replaced immediately. The lifetime of the battery is highly dependent on ambient temperature (and consequently on base temperature). If the maximum ambient temperatures (as recorded and displayed in menu: Information -> Fixture Temperatures -> Ambient Temperature -> Maximum NonRes.) are kept within the specified limits, the battery should last for at least two years. Should the ambient temperatures exceed the specified maximum temperature, the lifetime of the batteries could be considerably shortened even up to just one year or less and also result in physical damage (battery leakage) or unreliable fixture functions.

Damage caused by batteries failed due to exceeded maximum ambient temperature cannot be claimed under warranty terms.

Touch any part of the screen or press the [ENTER/Display On] button to display the initial screen with the current stored DMX address:

Touch the green arrow at the bottom right corner of the screen or press the [ENTER/Display On] button to enter

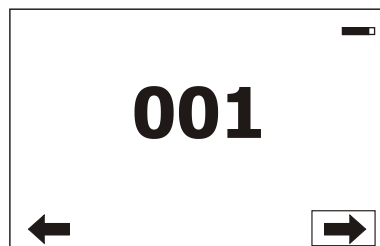

the "Address" menu.

An item (such as a Tab, menu item, text box, icon) may be selected from a screen by simply touching the item in the list or by pressing the [NEXT] or [PREV] buttons to scroll through list items. With each press, the next item is highlighted. Press [ENTER/Display On] to select the highlighted item.

Before first fixture operation, set current date and time in the menu "Date & Time Settings" (menu path: Personality--> Date & Time Settings).

7.1 Tab "Address"



Settings - Select the menu to set desired fixture address setting.

DMX Address - Select the menu to set the DMX start address.

Ethernet Settings - The menu allows all needed settings for the Ethernet operation

Disable - The option disables Ethernet operation.

Disable - The option disables Ethernet operation.

Artnet - Fixture receives Artnet protocol

gMAI - Fixture receives MANet 1 protocol

gMA2 - Fixture receives MANet 2 protocol

Art2DMX - Fixture receives Artnet protocol from the Ethernet input and sends DMX data to its DMX output (fixture works as an "Artnet/DMX converter", next fixture can be connected to its DMX output and you can build a standard DMX chain by connecting another fixtures. Only one fixture has to be connected to the Ethernet.

IP Address/Net Mask - Select this menu to set IP address. IP address is the Internet protocol address. The IP uniquely identifies any node (fixture) on a network. There cannot be 2 fixtures with the same IP address on the network!

Default IP Address -Preset IP address, you can set up only first byte of IP address (2 or 10) e.g. **002**.019.052.086.

Custom IP Address - The option enables to set up all bytes of IP address.

Net Mask - The option enables to set up all bytes of Net Mask.

ArtNet Universe - Use this item to set a Universe (0-255). The Universe is a single DMX 512 frame of 512 channels.

MANet Settings - Use this menu to set parameters for MANet operation.

MANet Universe I/II - The value of this item can be set in range 1-64.

MANet Session ID - The value of this item can be set in range 1-32.

7.2 Tab "Information"



Fixture Times - The menu provides readouts of fixture and lamp operation hours.

Power On Time Hours - Select this menu to read the number of fixture operation hours.

Total Hours - The item shows the total number of the operation hours since the Robin MMX Spot has been fabricated.

Resetable Hours - The item shows the number of the operation hours that the Robin MMX Spot has been powered on since the counter was last reset.

In order to reset this counter to 0, touch the text box next to the item "Resetable Hours:"

Lamp On Time Hours - Select this menu to read the number of the operation hours with the lamp on.

Total Hours - The item shows the total number of the operation hours with the lamp on since the Robin MMX Spot has been fabricated.

Resetable Hours - The item shows the number of the operation hours with the lamp on that the Robin MMX Spot has been powered on since the counter was last reset.

In order to reset this counter to 0, touch the text box next to the item "Resetable Hours:"

Lamp Strikes - Select this menu to read the number of lamp strikes.

Total Strikes - The item shows the total number of the lamp strikes since the Robin MMX Spot has been fabricated.

Resetable Strikes - The item shows the number of the lamp strikes since the counter was last reset.

In order to reset this counter to 0, touch the text box next to the item "Resetable Strikes:"

Air Filters - Regular cleaning of the air filters is very important for the fixture's life and performance.

Build-up of dust, dirt and fog fluid residues reduces the fixture's light output and cooling ability.

The two items of this menu help you to keep cleaning period of the air filters.

Alert period - Cleaning schedule for the fixture depends on the operating environment.

It is therefore impossible to specify accurate cleaning interval. This item allows you to change the cleaning interval of the air filters. This "alert" value is 300 hours and it is set as default. Inspect the fixture within its 300 hours of operation to see whether cleaning is necessary. If cleaning is required, clean all air filters and change the value in this menu on acceptable level. Min. level of alert period is 10 hours, max. is 300 hours.

Elapsed Time - The item allows you to read the time which remains to cleaning air filters.

The time period is set in the menu mentioned above.

Expired time period is signalled by a negative mark (-) at the time value and a warning icon on the display.

Clean the filters and reset this menu item (by touching the text box next to the item "Elapsed Time").

Fixture Temperatures - The menu is used to view temperatures of the fixture's inside.

Head Temperature - The menu shows temperatures in the fixture head near the lamp.

Current - A current temperature of the fixture head.

Maximum NonRes. - A maximum temperature of the fixture head since the fixture has been fabricated.

Maximum Res. - A maximum temperature of the fixture head since the counter was last reset.

In order to reset this counter to 0, touch the text box next to the item "Maximum Res."

Note: if the "Head Temperature" exceeds 115°C, the lamp will be switched off.

Base Temperature - The menu shows temperature in the fixture base (on the display PCB).

Current - A current temperature in the fixture base.

Maximum NonRes. - A maximum temperature in the fixture base since the fixture has been fabricated.

Maximum Res. - A maximum temperature in the fixture base since the counter was last reset.

In order to reset this counter to 0, touch the text box next to the item "Maximum Res."

Ambient Temperature - The menu shows temperature of the induced air on the fan in the fixture base .

Current - A current temperature of the induced air in the fixture base.

Maximum NonRes. - A maximum temperature of the induced air in the fixture base since the fixture has been fabricated.

Maximum Res. - A maximum temperature of the induced air in the fixture base since the counter was last reset.

In order to reset this counter to 0, touch the text box next to the item "Maximum Res."

Lamp Driver Temperature Level - The menu shows the temperature of the lamp driver in the base.

Current - A current temperature level of of the lamp driver.

Maximum NonRes. - A maximum temperature level of the of the lamp driver since the fixture has been fabricated.

Maximum Res. - A maximum temperature level of the of the lamp driver since the counter was last reset.

In order to reset this counter to 0, touch the text box next to the item "Maximum Res."

DMX Values - The menu is used to read DMX values of each channel received by the fixture.

Wireless State - The menu serves for reading of the wireless operation status (only for Wireless DMX version).

Unlink Wireless Adapter - The menu serves for unlinking the fixture from the transmitter (only Wireless DMX version)

Software Version - Select this item to read the software version of the fixture modules:

Display System - A display processor on the display board in the fixture base

Module M - A pan/Tilt processor on the board in the fixture arm.

Module G - A rot. gobo wheels processor on the board in the fixture head.

Module S - A strobe/colour/hot-spot processor on the board in the fixture arm

Module I - A dual graphic wheel /iris processor on the board in the fixture head.

Module O - A focus/zoom/prism/frost/ processor on the board in the fixture head.

Module C - CMY+CTO processor on the board in the fixture head.

Product IDs - The menu is used to read the MAC Address ,RDM UID and RDM Label.

View Logs - Use this menu to read fixture's data which have been recorded during fixture operation. This collected data allows easier troubleshooting.

Fixture Errors - Use this menu to read fixture errors which have occurred during fixture operation.

There is a list of error folders:

Pan Errors	Prism Errors
Tilt Errors	Prism Rotation Errors
Dimmer 1 Errors	Frost Errors
Dimmer 2 Errors	Cyan Errors
Colour Errors	Magenta Errors
HotSpot Errors	Yellow Errors
Gobo Errors	CTO Errors
Gobo Carousel Errors	Clean Air Filters
Static Gobo Errors	Lamp is Too Hot
Iris Errors	Overheated
Focus Errors	Active Lamp Timer
Zoom Errors	Lamp Errors
Base Overheated	Temp. Sensor Errors

Fixture States - Recorded following actions: Fixture On, Fixture Off, Lamp On, Lamp Off.

Fixture Position - Recorded installation positions of the fixture:

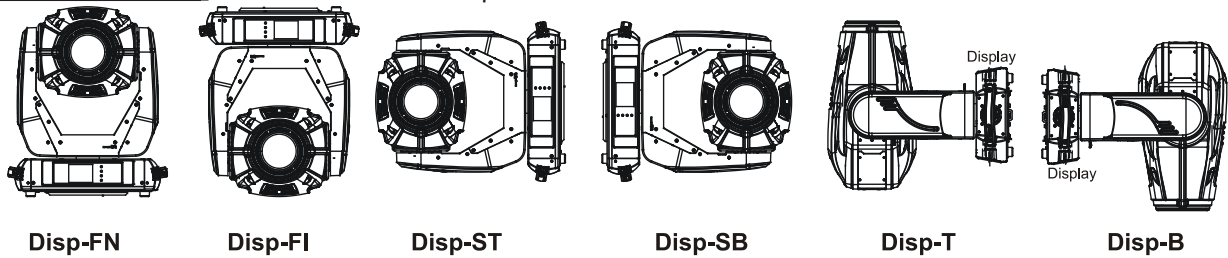

Fixture Temperatures - Recorded temperatures which have exceeded defined levels.

Note: The log buffer can contain 8000 records max. If the buffer is full, old data will be overwritten.

7.3 Tab "Personality"



User mode - The Robin MMX Spot allows you to recall up to 3 user settings. After switching the fixture on for the first time, the User A settings is active. Now all changes made in the "Personality" menu, "Addressing" menu and the "Music Trigger" and "Preset Playback" items from the "Stand-alone" menu are saved to the User A settings. If you now select the User B settings, from this moment the changes made in these menus will be saved to the User B settings. After switching the fixture off and on, the User B setting is active. In this way you may use the 3 fixture operating behaviours.

User A Settings - the function recalls the user A settings.

User B Settings - the function recalls the user B settings.

User C Settings - the function recalls the user C settings.

DMX Preset - Use the menu to select desired channel mode.

Mode 1 - 38 control channels

Mode 2 - 31 control channels

Mode 3 - 29 control channels

Mode 4 - 40 control channels

View Selected Preset - Use the menu to display channels included in the selected mode.

DMX Input - Use the menu to select mode of receiving DMX signal.

Wired - DMX signal is received by means of the standard DMX cable.

Wireless - DMX signal is received by means of the inbuilt wireless module.

Wireless In/XLR Out - the fixture receives wireless DMX and sends the signal to its wired DMX output.

The fixture behaves as "Wireless/Wired" adapter.

The options "Wired" and "Wireless" are also stated in DMX chart (channel Power/Special functions).

Pan/Tilt Settings - Use the menu set behaviour of both pan and tilt movements.

Pan Reverse - The item allows to invert pan movement.

Tilt Reverse - The item allows to invert tilt movement.

Pan/Tilt Feedback - The item allows to return the mowing head to the required pan/tilt position after changing the position by an external force if this option is set on.

Note. Be careful, the Pan/Tilt Feedback should be permanent On, the option Off is not suitable for standard operation and the head of the fixture can be damaged!

Pan/Tilt mode - Use this menu to set the mode of the pan/tilt movement

Time mode - The pan and tilt will move with different speeds and they will come at the same time to the end point of their tracks (pan and tilt use their optimal speeds).

Time of the pan/tilt movement (25.5 sec. max.) is set by the channel "Pan/Tilt speed, Pan/Tilt time".

Speed Mode - Both Pan and tilt will move with the same speed as adjusted at the channel "Pan/Tilt speed, Pan/Tilt time".

Pan/Tilt acceleration - Use the menu to set compatible or high acceleration of the head movement.

Microphone Sensitivity - Enter the menu if you want to adjust the microphone sensitivity from 1 (max.) to 20 (min.).

Blackout Settings - Use the menu if you need to close the light output under certain conditions which are described below

Blackout DMC - Blackout during movement correction. Set this option On if you wish to close light output during the time when the head goes to its correct position, which has been changed by an external force.

Active Blackouts - Use this menu if you wish to close the light output during effect changes.

Pan/Tilt Moving - The menu item enables to close light output while the pan/tilt coordinates are changing.

Colour Wheel Moving - The menu item enables to close light output while the colour wheel is moving.

Gobo Wheel Moving - The menu item enables to close light output while the rot. gobo wheel or the static gobo wheel is moving.

Timeout Blackout - If this function is On, the CMY flags go to the full position after 5 seconds after what the dimmer was closed in order to totally close light output of the fixture

Init Effect Positions - Use the menu to set all effects to the desired positions at which they will stay after switching the fixture on without DMX signal connected.

Screen Settings - Use this menu to change the touch screen settings.

Display Intensity - The item allows to control the intensity of the screen (1-min., 10-max.).

Screen saver Delay - The item allows you to keep the screen on or to turn it off automatically after 1-10 minutes after last touch (or pressing any button on the control panel).

Touchscreen Lock - The item allows you to lock the screen after last touch (or pressing any button on the control panel). The time delay can be set in range of 1-10 minutes. To unlock the screen, press the [ENTER/Display On] button.

Recalibrate Touchscreen - The item starts calibration of the touchscreen. Follow the instructions on the screen.

Display Orientation - The menu allows to change display orientation.

Normal - Standard display orientation if the fixture is placed horizontally (e.g. on the ground).

Inverted - Inverted orientation (needed if the fixture is hanging on the truss).

Auto - The option activates a gravitation sensor for automatic screen orientation.

Note: **Auto** option is set as default. You change the display orientation by touching the icon  on the display, and the option set in the "Display Orientation" menu is temporarily overridden.

Temperature unit - Use the menu item to change temperature unit from °C to °F.

Fan Mode - Use the menu to set the fixture fans to max. power mode ("**High**") or to auto-control mode ("**Auto**"). The third mode ("**Silent**") allows to set desired noise of the fixture fans and the adjusted noise level is kept during fixture operation. The "**Fan Noise Level**" menu serves for adjusting fans power from min. to max. To switch the fixture to the "Silent" mode can be also realized by DMX value from range of 241-255 on the "power/Special functions channel".

Note: the light output near min. level of the fan noise is reduced.

Magenta Correction - You can choose between deep tone of the magenta colour filter (On) or pale tone of the magenta colour filter (Off). This function influenced the "Compatible" CMY curve only.

CMY + CTO Curve - You can select desired running of CMY+CTO flags:

Compatible - compatible with previous versions of the Robin MMX Spot.

S-curve - improved distribution of the colour during colour flags movement.

After selecting desired curve, the "Magenta Correction" screen will appear, where you can choose between deep tone of the magenta colour (On) or pale tone of the magenta colour (Off).

Note: If you entered S-Curve, all flags except magenta and CTO are open, magenta is full and the level of the magenta tone can be set by means of the item **CTO Level**.

Dimmer Curve - You can select desired running of dimmer lamellas: Compatible or SYNC (linear).

Date & Time Settings - Use this menu to set current date and time for the fixture log system (menu "**View Logs**"). Set this menu item before first fixture operation.

Default Settings - The menu item allows to set all fixture parameters to the default (factory) values.

7.4 Tab "Manual Control"



Reset Functions - The menu allows to reset the fixture either per function modules or all modules together.

Total Reset - The item resets all function modules.

Pan/Tilt Reset - The item resets a pan and tilt movement.

Colour System Reset - The item resets a colour wheel and CMY/CTO flags.

Gobo System Reset - The item resets a static/rotating gobo wheel.

Dim./Strobe/H.-Spot Res. - The item resets strobe lamellas and a hot-spot module.

Zoom/Foc./Fro./Pri. Res. - The item resets a zoom, focus, prism and a frost module.

Iris/Dual G. Wheel Res. - The item resets an iris and dual graphic wheel module.

Preset Effect Control - Use the menu to show preset positions of each channel effect.

Manual Effect control - Use the menu to control all fixture channels by means of the control panel.

7.5 Tab "Stand-alone"



Test Sequences - Use the menu to run a test/demo sequences without an external controller, which will show you some possibilities of using Robin MMX Spot.

Dynamic Mode - This mode uses all Robin MMX Spot functions including pan/tilt movement and therefore is good for a complete introduction of the fixture.

Static Mode - This mode is suitable for projections on the wall, ceiling or ground without any pan/tilt movement. Adjust the pan, tilt, zoom, focus and hot-spot to desired positions and start test sequences by touching the green ► icon.

Music Trigger - Use the item to activate the sound control of the running program via the built-in microphone.

Preset Playback - This menu allows you to select the program which will be played in a loop after switching the fixture on (the option is commonly used in a stand-alone operation without an external controller).

None - The option disables "Presetting playback" function.

Test - The option starts the test sequences.

Prog. 1 - The option starts user program No. 1.

Prog. 2 - The option starts user program No. 2.

Prog. 3 - The option starts user program No. 3.

Play program - Use the menu to run desired program in a loop.

Play Program 1 - The option starts user program No. 1.

Play Program 2 - The option starts user program No. 2.

Play Program 3 - The option starts user program No. 3.

Edit Program - Use the menu to create or to edit desired program. The Robin MMX Spot offers 3 free programs, each up to 100 steps.

Edit Program 1 - The option allows to edit user program No. 1.

Edit Program 2 - The option allows to edit user program No. 2.

Edit Program 3 - The option allows to edit user program No. 3.

To edit program:

1. Touch the item which you want to edit ("Edit Program 1" - "Edit Program 3").





2. Touch the item "Edit Program Steps".

3. Touch the item "Step 1".

4. From the list of effects touch desired effect and set its value. Browse through the list by touching the [up arrow] and [down arrow] and set all desired effects.

- An item "Step Time" (value of 0-25.5 sec.) is the time during which effects last in the current step
- Save adjusted effects to the current step by touching the [confirm] or save and copy them to the following step by touching the [confirm+copy]. By touching the text box "Preview" next to the current program step you can view created scene.
 - Repeat the steps 4 and 5 for next program steps.
 - After editing desired program steps, adjust the length of the program by touching the text boxes "Start Step" and "End Step".

Meaning of the icons used in the "Edit Program" menu:

-  - moves down on the next page
-  - moves up on the previous page
-  - saves adjusted values and leaves menu
-  - saves values to the current step and copy them to the following prog. step
-  - leaves menu without saving values

There is a chart describing behaviour of items "Pan/Tilt Macro" and "P./T. Macro Speed".

DMX	Pan/Tilt Macro
0 - 9	Disabled pan/tilt macro
10 - 31	Reserved
32 - 63	Figure of circle (from small to large)
64 - 95	Figure of horizontal eight (from small to large)
96 - 127	Figure of vertical eight (from small to large)
128 - 159	Figure of rectangle (from small to large)
160 - 191	Figure of triangle (from small to large)
192 - 223	Figure of star (from small to large)
224 - 255	Figure of cross (from small to large)
	Pan/Tilt Macro Speed
0	No macro generation
1 - 127	Macro generation from fast to slow-forwards
128 - 129	No macro generation
130 - 255	Macro generation from slow to fast-backwards

7.6 Tab "Service"



Adjust DMX Values - The menu allows you to set all effects to desired positions before fine calibration of the effects .

Adjust Lamp - This item opens the light output of the fixture and enables to focus the light beam on the wall to perform the fine lamp adjustment.

Calibrations - This menu enables fine calibration of fixture effects and download default calibration values.

Calibrate Effects - The menu allows the fine adjustment of effects. The menu contains list of effects which can be calibrated:

Pan- a fine pan movement

Tilt - a fine tilt movement

Colour Wheel - a colour wheel

Cyan - cyan flags

Magenta - magenta flags

Yellow - yellow flags

CTO - CTO flags

Static Gobo - a static gobo wheel

Rot. Gobo Wheel - a carousel of rotating gobos

R. Gobo Index - an indexing of rotating gobo

Prism - a prism module

Iris - an iris module

Zoom - a zoom module

Focus - a focus module

HotSpot- a fine movement of reflector

Dimmer 1 - a dimmer lamella 1

Dimmer 2- a dimmer lamella 2

By using these items you can calibrate and adjust effects to their right positions.

Calibration via the control board

- Disconnect DMX controller from the fixture and enter the "Calibrate Effects" menu.
- Use the [up arrow] and [down arrow] to find desired effect and touch it to enter the fine effect adjustment screen.
- Set desired value and save it by touching the [confirm].

4. Repeat steps 2 and 3 for the next effects.
5. After calibrating all effects, touch the [confirm] to save all adjusted values and reset the fixture.

Calibration via the DMX controller

1. Connect DMX controller to the fixture and set fixture effects to the desired positions before fine calibration.
 2. Enter the "Calibrate Effects" menu and now you can exactly calibrate desired effects by DMX controller.
- A calibration protocol:

Effect	Mode 1	Mode 2	Mode 3	Mode 4
Pan	channel 39	channel 32	channel 30	channel 41
Tilt	channel 40	channel 33	channel 31	channel 42
Colour wheel	channel 41	channel 34	channel 32	channel 43
Cyan	channel 42	channel 35	channel 33	channel 44
Magenta	channel 43	channel 36	channel 34	channel 45
Yellow	channel 44	channel 37	channel 35	channel 46
CTO	channel 45	channel 38	channel 36	channel 47
Rot. Gobo 1 Wheel	channel 46	channel 39	channel 37	channel 48
R.Gobo 1 Index	channel 47	channel 40	channel 38	channel 49
Rot. Gobo 2 Wheel	channel 48	channel 41	channel 39	channel 50
Rot. Gobo 2 Index.	channel 49	channel 42	channel 40	channel 51
Prism	channel 50	channel 43	channel 41	channel 52
Iris	channel 51	channel 44	channel 42	channel 53
Zoom	channel 52	channel 45	channel 43	channel 54
Focus	channel 53	channel 46	channel 44	channel 55
Hot-Spot	channel 54	channel 47	channel 45	channel 56
Dimmer 1	channel 55	channel 48	channel 46	channel 57
Dimmer 2	channel 56	channel 49	channel 47	channel 58
Graph.Wheels Pos.	channel 57	channel 50	channel 48	channel 59

After having calibrated all effects, touch the [confirm] to save adjusted values and reset the fixture.

Load Default Calibrations - The item loads default (factory) calibration values.

Updating software - The menu item allows you to update software in the fixture via either serial or USB port of PC.

The following are required in order to update software:

- PC running Windows 95/98/2000/XP or Linux
- DMX Software Uploader
- Flash cable RS232/DMX No.13050624 (if you want to use a serial port of PC)
- Robe Universal Interface (if you want to use an USB port of PC)

Note 1: Software update should execute a qualified person. If you lack qualification, do not attempt the update yourself and ask for help your ROBE distributor.

Note 2: DMX address, IP address, programs 1-3 and all items in the menu "Personality" will be set to their default (factory) values.

To update software in the fixture:

I. Installation of the DMX Software Uploader.

1. DMX Software Uploader program is available from the ROBE web site at WWW.robe.cz.
2. Make a new directory (e.g. Robe_Uploader) on your hard disk and download the software to it.
3. Unpack the program from the archive. If the Robe fixture is produced in both magnetic and electronic ballast version, name of DMX Software Uploader is the same for both versions.

II. Fixture software updating.

1. Determine which of your ports is available on your PC and connect it:
 - with the DMX input of the fixture if you using the flash cable RS232/DMX
 - with the DMX output of the Robe Universal Interface if you using the USB cable.
 Disconnect the fixture from the other fixtures in a DMX chain. Turn both the computer and the fixture on. Make sure the lamp is switched off (only if the fixture involves a lamp).

2. Switch the fixture to the updating mode by touching the "Updating Software " item

Note: If you do not want to continue in software update, you have to switch off and on the fixture to escape from this menu.

We recommend to cancel all running programs before starting the Software Uploader.

3. Run the Software Uploader program. Select desired COM and then click on the Connect button.

(Select COM if the serial port is used or DreamBox1 if the USB port is used).

If the connection is OK, click on the "Start Uploading button" to start uploading. It will take several minutes to perform software update.

If the option "Incremental Update" is not checked, all processors will be updated (including processors with the same software version).

If you wish to update only later versions of processors, check the "Incremental Update box".

Avoid interrupting the process. Update status is being displayed in the Info Box window.

When the update is finished, the line with the text "The fixture is successfully updated" will appear in this window and the fixture will reset with the new software.

Note: In the case of an interruption of the upload process (e.g. power cut), the fixture keeps the updating mode and you have to repeat the software update again.

After software update please do a full power off/on cycle with a complete display blackout in order to reset battery error checking procedure.

Hardware Configuration - The menu item allows to set hardware configuration for CMY module. Option A, B or C has to be set according used CMY and CTO flags.

7.7 Icon "Lamp menu"



Lamp Status - The item enables to switch the lamp on/off. The Philips MSR Platinum 35 lamp is a cold restrike type, that means, that it has to be cold before striking.

Settings - The menu offers many items for setting of lamp behaviour.

Lamp Ignition Delay - The item allows to set the time delay(0-90sec.) before igniting the lamp by DMX command. If the lamp is started directly from the control panel, the time delay will be ignored.

Lamp Light Sensor - Select this item to switch the light sensor off. The option "On" is intended for a standard operation. The option "Off" is for "emergency operation" only! If the lamp light sensor is switched off, the fixture will still try to ignite the lamp (even when the lamp is damaged or absent), on this account some electronics parts of the fixture can be damaged!

Lamp On/Off Settings - Use the menu to set rules for automatic switching on/off the lamp.

Lamp On Power On - If the item is on, the lamp will be automatically turn on after switching the fixture on.

Lamp Off via DMX - The item enables to switch the lamp off via DMX command from DMX controller.

Lamp On if DMX Present - The item allows you to strike the lamp automatically after 26 seconds if DMX signal is present on the fixture's DMX input.

Lamp Off if not DMX - The item allows you to switch off the lamp automatically after 2 minutes if DMX signal is missing on the fixture's DMX input.

8. RDM

This fixture supports RDM operation. RDM (Remote Device Management) is a bi-directional communications protocol for use in DMX512 control systems, it is the new open standard for DMX512 device configuration and status monitoring.

The RDM protocol allows data packets to be inserted into a DMX512 data stream without adversely affecting existing non-RDM equipment. By using a special „Start Code,“ and by complying with the timing specifications for DMX512, the RDM protocol allows a console or dedicated RDM controller to send commands to and receive messages from specific moving lights.

RDM allows explicit commands to be sent to a device and responses to be received from it.

The list of commands for Robin MMX Spot is the following.

Parameter ID	Discovery command	SET command	GET command
DISC_UNIQUE_BRANCH	*		
DISC_MUTE	*		
DISC_UN_MUTE	*		
DEVICE_INFO			*

SUPPORTED_PARAMETERS			*
SOFTWARE_VERSION_LABEL			*
DMX_START_ADDRESS		*	*
IDENTIFY_DEVICE		*	*
DEVICE_MODEL_DESCRIPTION			*
MANUFACTURER_LABEL			*
DEVICE_LABEL		*	*
SENSOR_DEFINITION			*
SENSOR_VALUE			*
DISPLAY_INVERT		*	*
DISPLAY_LEVEL		*	*
PAN_INVERT		*	*
TILT_INVERT		*	*
DEVICE_RESET		*	
DMX_PERSONALITY		*	*
DMX_PERSONALITY_DESCRIPTION			*
STATUS_MESSAGES			*
STATUS_ID_DESCRIPTION			*
LAMP_STATE		*	*
LAMP_ON_MODE ¹		*	*
DEVICE_HOURS ²			*
LAMP_HOURS ²			*
LAMP_STRIKES ²			*

¹...Another options for this command (only for Robe's fixtures):

value PARAMETER_DATA=0x84 - lamp OFF by DMX value on DMX channel

value PARAMETER_DATA=0x88 - lamp OFF if DMX is not present

²...Commands relative resetable values

9. Wireless DMX operation

The wireless version of the Robin MMX Spot is equipped with the Lumen Radio CRMX module and antenna for receiving DMX signal. CRMX module operates on the 2.4 GHz band.

The item " Wireless " from the menu "DMX Input" allows you to activate receiving of wireless DMX (Personality--> DMX Input -->Wireless.). First two options from the "DMX Input" menu are stated in DMX chart as well (channel Power/Special functions , range of 10-19 DMX). If DMX input option is changed by DMX command, the change is permanently written into fixture's memory.

DMX range of 10-19 switching fixture to the wired/wireless operation is active only during first 10 seconds after switching the fixture on.

After switching the fixture on, the fixture checks both modes of receiving DMX in the following order:

1. For the first five seconds, the fixture receives DMX signal from the wired input. If the Power/Special functions channel is set at some DMX input option, the fixture will receive DMX value according to this option. If DMX input option is set to the wired input , this option is saved and checking procedure is finished. If DMX input option is not set, the fixture continues next 5 seconds in scanning wireless DMX signal-see point 2.

2. For the next 5 seconds the fixture receives wireless DMX signal and again detects if the Power/Special functions channel is set at some DMX input option, if not, the fixture will take option which is set in the fixture menu "DMX Input".

To link the fixture with DMX transmitter.

The fixture can be only linked with the transmitter by running the link procedure at DMX transmitter .

After linking , the level of DMX signal (0-100 %) is displayed in the menu item "Wireless State" (Information

-->Wireless State).

To unlink the fixture from DMX transmitter.

The fixture can be unlinked from receiver via the menu item “Unlink Wireless Adapter” (Information--> Wireless State --> Unlink Wireless Adapter.).

10. Error and information messages

Occurred errors during fixture operation are signalled by the yellow warning icon at the bottom line of the screen:

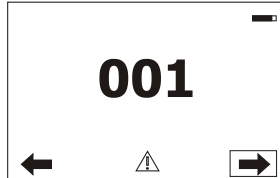

Touch the warning icon or press the [ESCAPE] button to display error messages.

List of error and information messages:

Active Lamp Timer

This message appears if you try to switch on the lamp within 5 minutes after having switched it off. The fixture will store the attempt to ignite the lamp and automatically ignites the lamp when the 5 minutes period will expire.

Lamp Error

If the ignition of the lamp is 4 times unsuccessful (the “Active Lamp Timer” message appeared 3 times before), the display shows “Lamp Error”, meaning that the lamp could be damaged or even missed or there could be a failure on the igniter or ballast.

Overheated

This message informs that the fixture head has been overheated and the lamp was switched off by means of the head temperature sensor.

Base Overheated

This message informs that the fixture base has been overheated and the lamp was switched off by means of the lamp driver temperature sensor in the base.

Lamp is too hot

The message will appear on the display if the lamp doesn't ignite within 5 seconds.

Temper.Sensor Error

The message informs you that the communication between the head temperature sensor and the main processor failed and the lamp has been switched off.

Tilt Error 1 (Tilt Error 2)

This message will appear after the reset of the fixture if the head's magnetic-indexing circuit malfunctions (sensor failed or magnet is missing) or the stepping motor is defective or its driving IC on the PCB. The head is not located in the default position after the reset.

Pan Error 1 (Pan Error 2)

This message will appear after the reset of the fixture if the yoke's magnetic-indexing circuit malfunctions (sensor failed or magnet is missing) or the stepping motor is defective or its driving IC on the PCB. The yoke is not located in the default position after the reset of the fixture.

Colour Wheel Error 1(Colour Wheel Error 2)

The messages will appear after the reset of the colour wheel if this wheel is not located in the default position.

Cyan Lamella Error 1 (Cyan Error 2)

The messages will appear after the reset of the cyan flag if the flag is not located in the default position.

Magenta Lamella Error 1 (Magenta Error 2)

The messages will appear after the reset of the magenta flags if the flag is not located in the default position.

Yellow Lamella Error 1 (Yellow Error 2)

The messages will appear after the reset of the yellow flags if the flag is not located in the default position.

CTO Lamella Error 1 (CTO Lamella Error 2)

The messages will appear after the reset of the CTO flag if the flag is not located in the default position.

Strobe 1 Error 1 (Strobe 1 Error 2)

The messages will appear after the reset of the dimmer/strobe module if the strobe lamella 1 is not located in the default position.

Strobe 2 Error 1 (Strobe 2 Error 2)

The messages will appear after the reset of the dimmer/strobe module if the strobe lamella 2 is not located in the default position.

Prism Error 1 (Prism Error 2)

The messages will appear after the reset of the prism wheel if this wheel is not located in the default position.

Zoom Error 1 (Zoom Error 2)

The messages will appear after the reset of the zoom module if the zoom lens is not located in the default position.

Focus Error 1 (Focus Error 2)

The messages will appear after the reset of the focus module if the focus lens is not located in the default.

Gobo Carousel 1 Error 1 (Gobo Carousel 1 Error 2)

The messages will appear after the reset of the gobo carousel 1 if this wheel is not located in the default position.

Gobo rotation 1 Error 1 (Gobo Rotation 1 Error 2)

The messages will appear after the reset of the rotating gobo wheel 1 if the rotating gobos are not located in the default positions.

Gobo Carousel 2 Error 1 (Gobo Carousel 2 Error 2)

The messages will appear after the reset of the gobo carousel 2 if this wheel is not located in the default position.

Gobo rotation 2 Error 1 (Gobo Rotation 2 Error 2)

The messages will appear after the reset of the rotating gobo wheel 2 if the rotating gobos are not located in the default positions.

Faulty battery

The battery on the display board is exhausted and should be replaced immediately.

Clean Air Filters

The message informs that the item "Elapsed Time" in the "Fixture Information" menu is at 0 value. Clean air filters and reset this counter.

Lamp Fans Bad, Lamp Off

One of the blowers (Fan 1, Fan 2) over the lamp malfunctions and the lamp was switched off.

Front Fans Bad, Lmp. Pw. R.

One of the blowers (Fan 3, Fan 4) in the fixture head malfunctions and the lamp power was reduced to 500W.

Gobo Fan Bad, Lamp Off

The small blower (Fan 5) over gobo wheels malfunctions and the lamp was switched off.

Base Fans Bad, Lamp Off

One of the fans (suction fan Fan7, blow Fan 8) in the fixture base malfunctions and the lamp was switched off.

Location of the fans:

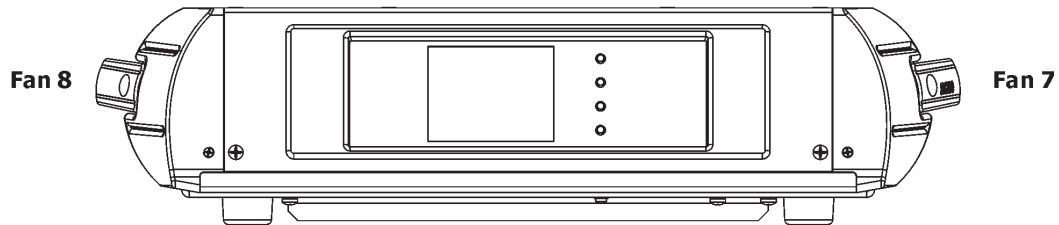
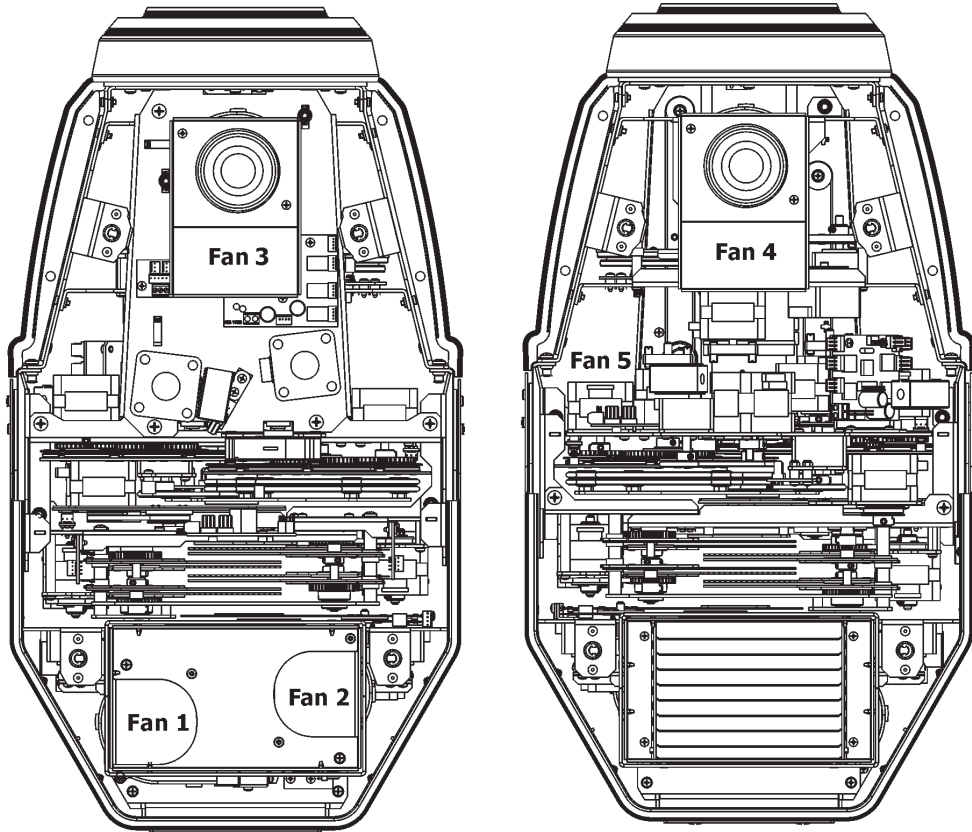

11. Technical Specifications

Electrical

Power supply:.....electronic auto-ranging
Input voltage range:..... 100-240V, 50/60Hz
Power consumption* @230V: 1020W (I= 4.87A , power factor=0.91)
Fuse:.....T 8 A@230V, T 15 A@120V
*Allow for a deviation of +/-10%

Lamp

Approved model: MSR Platinum 35 (55,000 lumens, CRI>75, CCT=7800K, 750 hrs life)
Base:PGJX 36

Ballast

Electronic

Optical System

High luminous-efficiency glass reflector
zoom range: 8.5 ° - 42.5° (gobo) ; 9.8° – 46.5 ° (open hole)

Colour wheel

6 dichroic filters + open

CMY + CTO mixing module

Smooth CMY colour mixing system
Colour temperature correction filter lowers the colour temperature to 3200 K
30 colour macros

Rotating gobo wheel 1

6 glass gobos + one dichro gobo can be indexed and rotated in both directions at different speeds
Gobo wheel continuous rotation
Glass gobos: outside diameter=26.8 mm, max. thickness=4 mm, high temperature borofloat or better glass
"Slot&lock" system for easy replacement of gobos

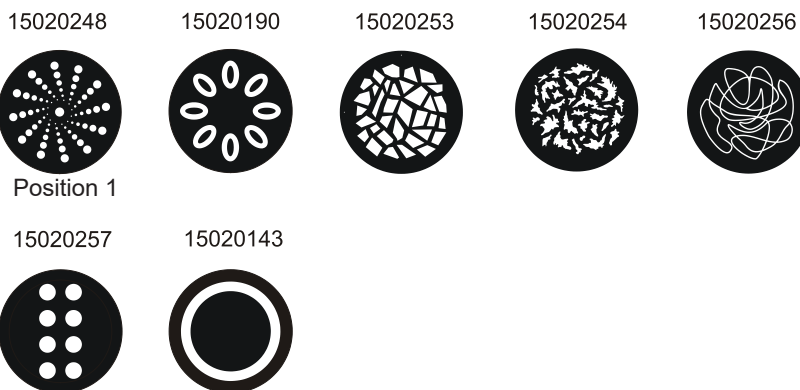

Rotating gobo wheel 2

7 glass gobos can be indexed and rotated in both directions at different speeds
Gobo wheel continuous rotation
Glass gobos: outside diameter=26.8 mm, max. thickness=4 mm, high temperature borofloat or better glass
"Slot&lock" system for easy replacement of gobos

15020255



Position 1

15020249



15020250

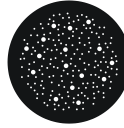

15020178



15020252



15020251



15030030



Prism

Rotating 5-facet prism with continuous rotation in both directions

Iris

Motorized iris for different beam diameters

Frost filter

Separate, variable frost filter

Zoom

Linear motorized zoom

Dual graphic wheel

2 graphic wheels rotating in both directions

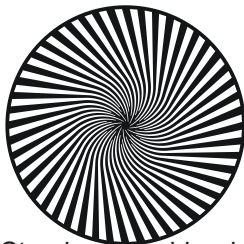

Standard graphic wheels



Optional graphic wheels (included)

Strobe

Strobe effect with variable speed (max. 15 flashes/sec.)
Electronic strobbing (max. 33 flashes/sec.)

Dimmer

Smooth dimmer from 0 - 100 %

Control

Graphic touch screen for fixture setting and addressing
Gravitation sensor for auto screen positioning
Battery backup of the touch screen
Readout fixture and lamp usage, receiving DMX values, temperatures, etc
Built-in analyzer for easy fault finding, error messages
Remotely switching on/off the lamp
Built-in demo sequences
Black-out while head moving, colour or gobo changing
Silent fans cooling,
Self-resetable thermo-fuse
Stand-alone operation
3 user editable programs, each up to 100 steps
Supported protocols: USITT DMX 512, RDM, ArtNet, MANet, MANet2
Support of RDM (Remote Device Management)
4 DMX modes (38, 31, 29, 40 control channels)

Wireless DMX/RDM module (only for Wireless DMX version)

Compliance with USITT DMX-512 (1986 & 1990) and 512-A
Full DMX fidelity and frame integrity
Auto sensing of DMX frame rate and frame size
<5ms DMX latency
Operational frequency range of 2402-2480 MHz
Producer: LumenRadio

Pan/Tilt

Pan movement range 540°
Tilt movement range 270°
16 bit movement resolution
Automatic Pan/Tilt position correction
Remotely controllable speed of pan/tilt movement for easy programming
Pan/tilt-lock mechanism

Rigging

Mounting points: 2 pairs of 1/4-turn locks
Mounting horizontally or vertically via 2 Omega brackets

Temperatures

Maximum ambient temperature : 45° C
Maximum housing temperature : 100° C

Minimum distances

Min. distance from flammable surfaces: 1 m
Min. distance to alight object: 5 m

Connection

DMX data in/out: Locking 3-pin and 5-pin XLR
ArtNet: RJ 45 (Neutrik Ethercon)
AC power IN: Chassis connector Neutrik PowerCon, A-type, NAC3MPA

Total heat dissipation

3480 BTU/h (calculated)

Weight (net):

25.5 kg

Dimensions (mm)

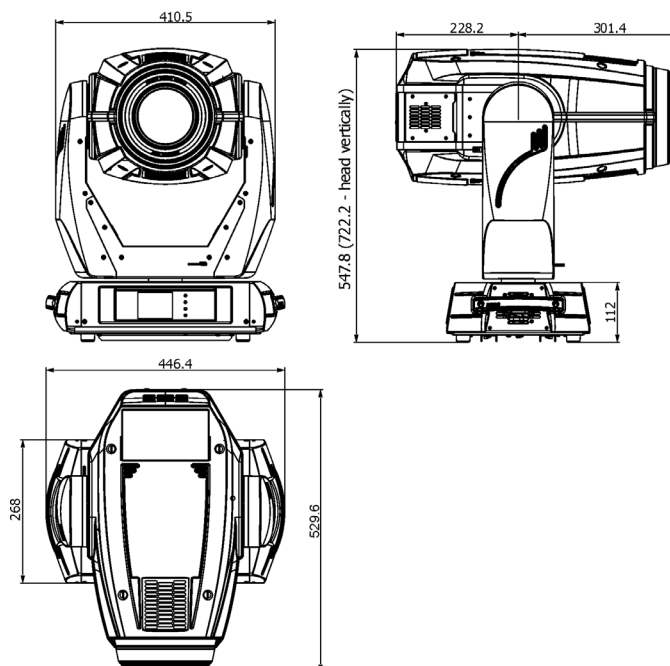

Accessories

Omega Adaptor CL-regular 2 pcs in box (P/N 10980033).....	1 piece
Gobo-set 18 /two graphic wheels included/ (P/N 15050027)	1 piece
Mains fuse 15A; EU version only (P/N 13052026).....	1 piece
Air filter(P/N 17030658).....	2 pieces
Air filter(P/N 17030655).....	1 piece
Mains cable	1 piece

Photometric charts

Lamp: MSR Platinum 35
 Beam angles are mesured at free hole

Beam angle 9.8° - Min. Zoom

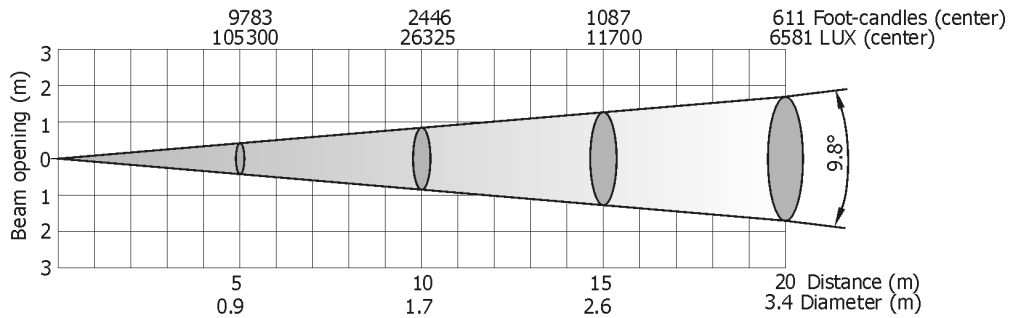

Beam angle 9.8° with frost

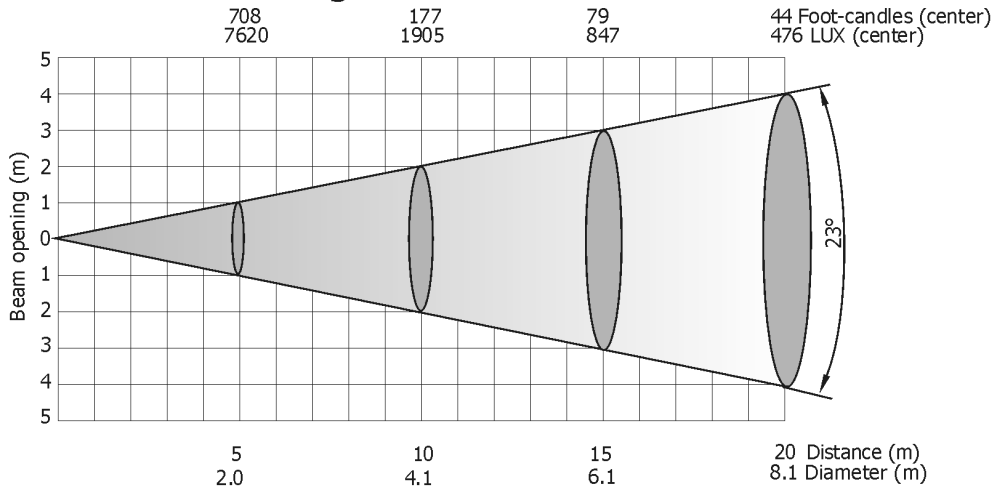

Beam angle 9.8° with frost, distance=5m

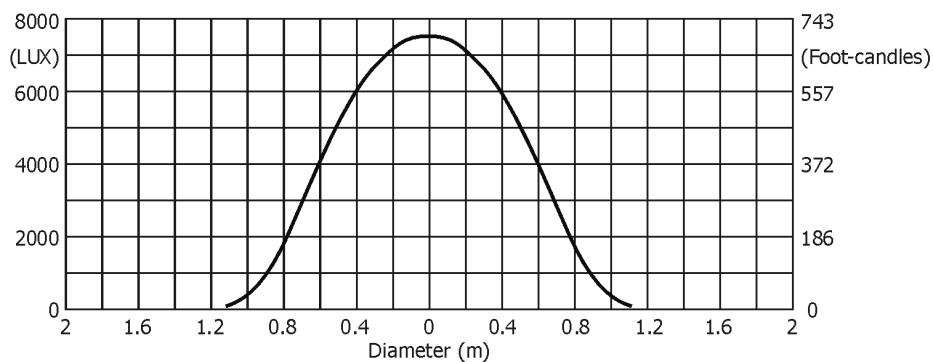

Lamp: MSR Platinum 35
 Beam angles are mesured at free hole

Beam angle 46.5° - Max. Zoom

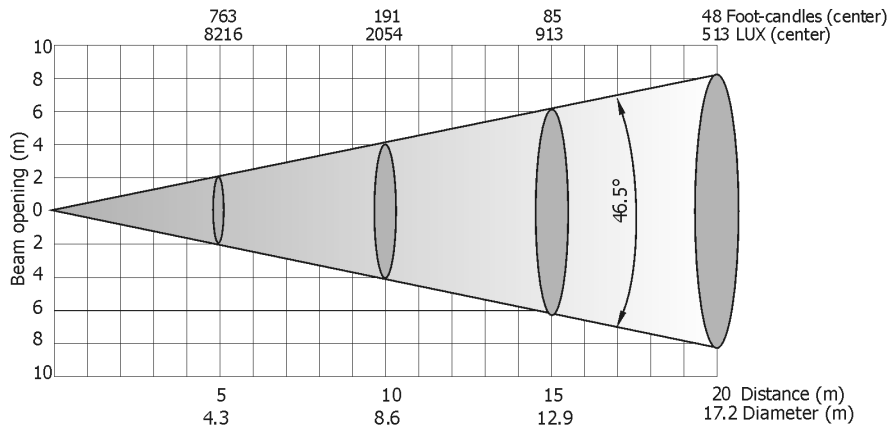

Beam angle 46.5° with frost

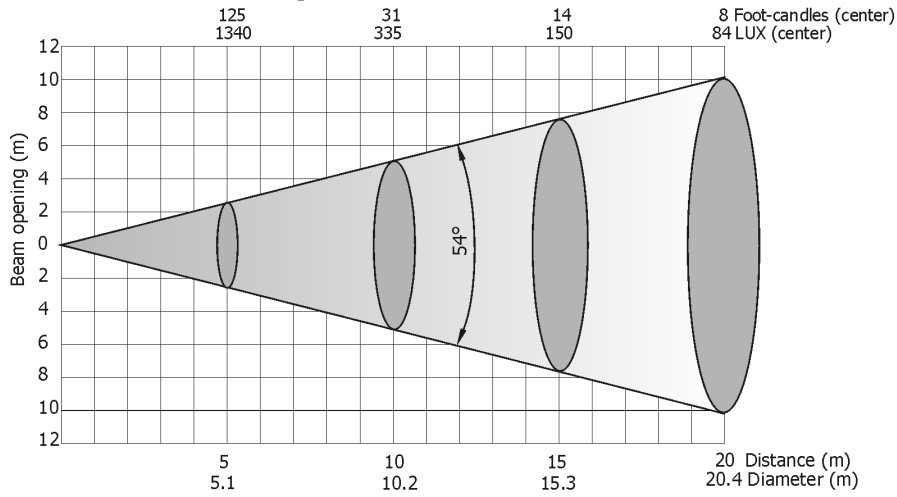

Beam angle 46.5° with frost, distance=5m

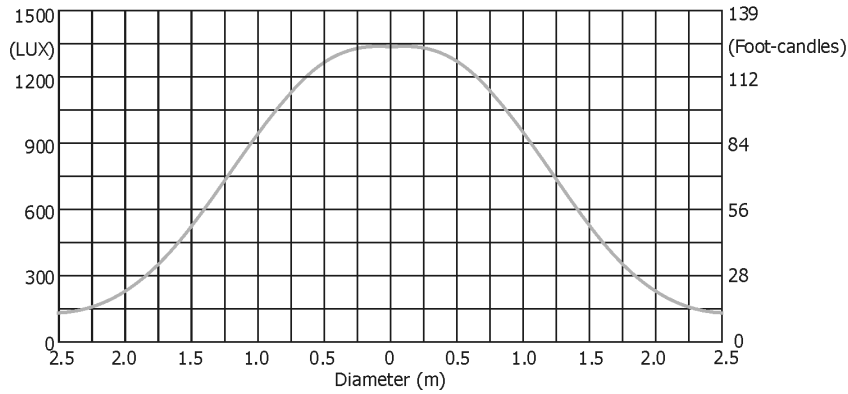

12. Maintenance and cleaning

It is absolutely essential that the fixture is kept clean and that dust, dirt and smoke-fluid residues must not build up on or within the fixture. Otherwise, the fixture's light-output will be significantly reduced. Regular cleaning will not only ensure the maximum light-output, but will also allow the fixture to function reliably throughout its life. A soft lint-free cloth moistened with any good glass cleaning fluid is recommended, under no circumstances should alcohol or solvents be used!

DANGER !
**Disconnect from the mains before starting any
 maintenance work**

The front objective lens will require weekly cleaning as smoke-fluid tends to building up residues, reducing the light-output very quickly. The cooling-fans should be cleaned monthly.

The interior of the fixture should be cleaned at least annually using a vacuum-cleaner or an air-jet.

Dichroic colour filters, CMY lamellas, gobo and graphic wheels and the internal lenses should be cleaned monthly. Remove dust and dirt from the fans and cooling vents using a soft brush and vacuum-cleaner.

Important! Check the air filters periodically and clean before they become clogged!

Clean 2 air filters placed in the fixture's covers and one in the fixture base. Use a vacuum cleaner, compressed air or you can wash them and put back dry.

After replacing the air filters, reset the elapsed time counter in the menu "Information" (Information--->Air Filters---> Elapsed Time).

Replacing the fuse.

Before replacing the fuse, unplug mains lead.

- 1) Remove the fuse holder on the rear panel of the base with a fitting screwdriver from the housing (anti-clockwise).
- 2) Remove the old fuse from the fuse holder.
- 3) Install the new fuse in the fuse holder (only the same type and rating).
- 4) Replace the fuseholder in the housing and fix it.

13. ChangeLog

This section summarizes all types of changes in the user manual.

Version of the manual	Date of issue	Description of changes
2.2	02/05/2018	Pan/tilt specification corrected
2.1	7/12/2017	Accessories updated
2.0	22/01/2015	Added menu item Pan/Tilt acceleration into menu Personality
1.9	15/01/2014	Removed one fuse holder from rear panel of the fixture base, added PowerCon
1.8	13/8/2013	New DMX chart v.1.7 (mode 4 added)
1.7	21/9/2012	Tab "Service", added new item Hardware Configuration
1.6	14/12/2011	Tab Personality,added new item:DMX Input New DMX chart v. 1.5. Added switching Wired/Wireless DMX on Power/ Special functions channel (DMX range 10-19). New description of wireless operation
1.5	28/11/2011	Tab Personality,added new items:CMY+CTO Curve Tab Personality, removed item : CMY Correction
1.4	21/11/2011	New DMX chart v. 1.4. Added switching dimmer curves on Power/Special functions channel (DMX range 40-49). Tab Personality, added new items :CMY+CTO Curve, Dimmer Curve

May 2, 2018

Copyright © 2011-2018 Robe Lighting - All rights reserved

All Specifications subject to change without notice

Made in CZECH REPUBLIC by ROBE LIGHTING s.r.o. Palackeho 416/20 CZ 75701 Valasske Mezirici

DMX protocol

Robin MMX Spot - DMX protocol, version 1.7							
(For fixtures produced after 25/08/2013 or updated with a software DSU_RobinMMXSpot_13081343.zip (DSU_RobinMMXSpot_13081343.tar.bz2) or latter .							
DSU RobinPointe_YMMDDTT.zip -->YY=year, MM=month, DD= day.)							
Mode/channel				DMX Value	Function	Type of control	
1	2	3	4				
1	1	1	1		Pan		
				0 - 255	Pan movement by 540°	proportional	
2	2	*	2		Pan Fine		
				0 - 255	Fine control of pan movement	proportional	
3	3	2	3		Tilt		
				0 - 255	Tilt movement by 270°	proportional	
4	4	*	4		Tilt fine		
				0 - 255	Fine control of tilt movement	proportional	
5	5	3	5		Pan/Tilt speed , Pan/Tilt time		
				0	Standard mode	step	
				1	Max. Speed Mode	step	
					Pan/Tilt speed mode		
				2 - 255	Speed from max. to min.	proportional	
					Pan/Tilt time mode		
				2 - 255	Time from 0.2 s to 25.5 sec.	proportional	
6	6	4	6		Power/Special functions		
				0 - 9	Reserved		
					<i>To activate following functions, stop in DMX value for at least 3 s and shutter must be closed at least 3 sec. („Shutter,Strobe“ channel 36/30/28 must be at range: 0-31 DMX). Corresponding menu items are temporarily overridden except DMX Input.</i>		
				10-14	DMX input: Wired DMX *	step	
				15-19	DMX input: Wireless DMX *	step	
					* function is active only 10 seconds after switching the fixture on		
				20-39	Reserved		
				40-44	Dimmer-Compatible curve	step	
				45-49	Dimmer-SYNC curve	step	
				50 - 59	Pan/Tilt speed mode	step	
				60 - 69	Pan/Tilt time mode	step	
				70 - 79	Blackout while pan/tilt moving	step	
				80 - 89	Disabled blackout while pan/tilt moving	step	
				90 - 99	Blackout while colour wheel moving	step	
				100 - 109	Disabled blackout while colour wheel moving	step	
				110 - 119	Blackout while gobo wheel moving	step	
				120-129	Disabled blackout while gobo wheel moving	step	
					<i>To activate following functions, stop in DMX value for at least 3 seconds.</i>		
				130 - 139	Lamp On,reset(total reset except pan/tilt reset)	step	
				140 - 149	Pan/Tilt reset	step	
				150 - 159	Colour system reset	step	
				160 - 169	Gobo wheels reset	step	
				170 - 179	Dimmer/Shutter/Hot-spot reset	step	
				180 - 189	Zoom/focus/frost/prism reset	step	
				190 - 199	Iris/dual graphic wheel reset	step	
				200 - 209	Total reset	step	

DMX protocol

(For fixtures produced after 25/08/2013 or updated with a software DSU_RobinMMXSpot_13081343.zip (DSU_RobinMMXSpot_13081343.tar.bz2) or latter .

DSU RobinPointe_YYMMDDTT.zip -->YY=year, MM=month, DD= day.)

				210 - 229	Reserved	
				230 - 239	Lamp Off	step
				240	Disabled "Silent" mode of fans	step
					<i>To activate the "Silent mode", stop in range of 241-255 at least 3 sec.</i>	
				241-255	Silent mode of fans: Fans noise fom min. to max	proportional
7	7	5	7		Colour wheel	
					Continual positioning	
				0	Open/white	proportional
				18	Deep red	proportional
				34	Deep blue	proportional
				55	Orange	proportional
				73	Green	proportional
				91	Amber	proportional
				110	UV filter	proportional
				128-129	White	step
					Positioning	
				130-139	Deep red	step
				140-149	Deep blue	step
				150-159	Orange	step
				160-169	Green	step
				170-179	Amber	step
				180-189	UV filter	step
				190 - 215	Forwards rainbow effect from fast to slow	proportional
				216 - 217	No rotation	step
				218 - 243	Backwards rainbow effect from slow to fast	proportional
				244 - 249	Random colour selection by audio control	step
					(Set microphone sensitivity in menu „Personality“)	
				250 - 255	Auto random colour selection from fast to slow	proportional
8	*	*	8		Colour wheel - fine positioning	
				0 - 255	Fine positioning	proportional
9	8	6	9		Cyan	
				0 - 255	Cyan (0-white, 255-full cyan)	proportional
10	9	7	10		Magenta	
				0 - 255	Magenta (0-white, 255-full magenta)	proportional
11	10	8	11		Yellow	
				0 - 255	Yellow (0-white, 255-full yellow)	proportional
12	11	9	12		CTO filter	
				0 - 255	(0-6900K, 255-3200K)	proportional
13	12	10	13		CMY colour macros	
				0 - 7	No function	step
				8 - 15	Macro 1	step
				16 -23	Macro 2	step
				24-31	Macro 3	step
				32-39	Macro 4	step
				40-47	Macro 5	step
				48-55	Macro 6	step
				56-63	Macro 7	step
				64-71	Macro 8	step
				72-79	Macro 9	step

DMX protocol

(For fixtures produced after 25/08/2013 or updated with a software DSU_RobinMMXSpot_13081343.zip (DSU_RobinMMXSpot_13081343.tar.bz2) or latter .

DSU RobinPointe_YYMMDDTT.zip -->YY=year, MM=month, DD= day.)

				80-87	Macro 10	step
				88-95	Macro 11	step
				96-103	Macro 12	step
				104-111	Macro 13	step
				112-119	Macro 14	step
				120-127	Macro 15	step
				128-135	Macro 16	step
				136-143	Macro 17	step
				144-151	Macro 18	step
				152-159	Macro 19	step
				160-167	Macro 20	step
				168-175	Macro 21	step
				176-183	Macro 22	step
				184-191	Macro 23	step
				192-199	Macro 24	step
				200 - 207	Macro 25	step
				208 - 215	Macro 26	step
				216 - 223	Macro 27	step
				224 - 231	Macro 28	step
				232 - 239	Macro 29	step
				240 - 243	Macro 30	proportional
				244 - 249	Random macro selection by audio control (Set microphone sensitivity in menu "PErsonality")	step
				250 - 255	Auto random macro selection from fast to slow	proportional
14	13	11	14		Effect Speed	
					<i>Speed of CMY&CTO movement and Rot. Gobo selection</i>	
				0-255	Speed of CMY+CTO movement from max. to min.	proportional
				0-255	Speed of Rot. Gobo Selection from max. to min.	proportional
*	*	*	15		CMY+CTO+Colour wheel time	
				0	Function is off	step
				1 - 255	Time of CMY, CTO and Colour wheel movement (0.1sec-->25.5sec.)	proportional
*	*	*	16		Zoom+Focus+Iris+Frost+Prism time	
				0	Function is off	step
				1 - 255	Time of zoom, focus, iris and frost movement (0.1 sec-->25.5 sec.)**	proportional
				1-50	Time of prism movement (0.1 sec-->5 sec.)**	proportional
15	14	12	17		Dual graphic wheel positioning	
				0-19	No function	step
				20-127	Proportional indexing (73-center)	proportional
				128-170	Ramping from open to full position (max--->min. speed)	proportional
				171-213	Ramping from open to half position (max. --->min. speed)	proportional
				214-255	Ramp. from half position to full position (max. --->min. speed)	proportional
16	15	13	18		Dual graphic wheel-Graphic wheel 1 rotation	
				0	No rotation	step
				1 - 127	Forwards rotation from fast to slow	proportional
				128 - 129	No rotation	step
				130 - 255	Backwards rotation from slow to fast	proportional
17	16	14	19		Dual graphic wheel-Graphic wheel 2 rotation	
				0	No rotation	step

DMX protocol

(For fixtures produced after 25/08/2013 or updated with a software DSU_RobinMMXSpot_13081343.zip (DSU_RobinMMXSpot_13081343.tar.bz2) or latter . DSU_RobinPointe_YYMMDDTT.zip -->YY=year, MM=month, DD= day.)						
				1 - 127	Forwards rotation from slow to fast	proportional
				128 - 129	No rotation	step
				130 - 255	Backwards rotation from slow to fast	proportional
18	17	15	20		Dual graphic wheel animations	
				0-7	No animation	
					Note : Set suitable DMX value at Focus channel to get desired animation. All animation were created at distance 7 m from screen with zoom=135DMX, Focus value was different for each effect (focus value is stated in parentheses for this distance)	
					Distance=7m, Zoom=135, Focus- see below	
					<u>Colour animations (standard graphic wheels)</u>	
					Note : The channels are blocked: Colour wheel, Cyan, Magenta, Yellow, CMY colour macros, Rotating gobo wheel 1 and 2, Prism, Prism rotation	
					<i>* use Rot. Gobo 1 indexing and rotation channel to index the animation</i>	
				8-9	Fire (Focus=95) *	step
				10-11	Bonfire (F=93) *	step
				12-13	Water (F=87)*	step
				14-15	Clouds (F=98)*	step
				16-17	Snowfall (F=78)	step
				18-19	Rain (F=91)*	step
				20-21	Gold fishes (F=39)	step
				22-23	Colour fishes (F=39)	step
				24-25	Fishes to shoal (F=39)	step
				26-27	Pie (F=85)	step
				28-29	Fishes from shoal (F=49)	step
				30-31	Sun (F=156)	step
				32-33	Falling leafs (F=43)	step
				34-35	Tunnel 1 (F=50)	step
				36-37	Tunel 2 (F=52)	step
				38-39	Pupil (F=81)	step
				40-41	Radial circles (F=135)	step
				42-43	Comet 1 (F=46)	step
				44-45	Comet 2 (F=39)	step
				46-47	Star cluster (F=74)	step
				48-49	Crochet ornament (F=78)	step
				50-51	Maelsrom (F=24)	step
				52-53	Sun on water (F=73)	step
				54-55	Pearly jewellery (F=95)	step
				56-57	Heap of bars (F=91)	step
				58-59	Nebula (F=20)	step
				60-61	Eccentric eye (F=67)	step
				62-63	Radial ellipses (F=102)	step
				64-65	Flying ball (F=70)	step
				66-67	Spaghetti (F=108)	step
					<u>Black and white animations (standard graphic wheels)</u>	
					Note : The channels are blocked: Rotating gobo wheel 1 and 2, Prism, Prism rotation	

DMX protocol

(For fixtures produced after 25/08/2013 or updated with a software DSU_RobinMMXSpot_13081343.zip (DSU_RobinMMXSpot_13081343.tar.bz2) or latter .

DSU RobinPointe_YYMMDDTT.zip -->YY=year, MM=month, DD= day.)

					<i>* use Rot. Gobo 1 indexing and rotation channel to index the animation</i>	
				68-69	Fire (Focus=95) *	step
				70-71	Bonfire (F=93) *	step
				72-73	Water (F=87)*	step
				74-75	Clouds (F=98)*	step
				76-77	Snowfall (F=78)	step
				78-79	Rain (F=91)*	step
				80-81	Gold fishes (F=39)	step
				82-83	Colour fishes (F=39)	step
				84-85	Fishes to shoal (F=39)	step
				86-87	Pie (F=85)	step
				88-89	Fishes from shoal (F=49)	step
				90-91	Sun (F=156)	step
				92-93	Falling leafs (F=43)	step
				94-95	Tunnel 1 (F=50)	step
				96-97	Tunel 2 (F=52)	step
				98-99	Pupil (F=81)	step
				100-101	Radial circles (F=135)	step
				102-103	Comet 1 (F=46)	step
				104-105	Comet 2 (F=39)	step
				106-107	Star cluster (F=74)	step
				108-109	Crochet ornament (F=78)	step
				110-111	Maelsrom (F=24)	step
				112-113	Sun on water (F=73)	step
				114-115	Pearly jewellery (F=95)	step
				116-117	Heap of bars (F=91)	step
				118-119	Nebula (F=20)	step
				120-121	Eccentric eye (F=67)	step
				122-123	Radial ellipses (F=102)	step
				124-125	Flying ball (F=70)	step
				126-127	Spagheti (F=108)	step
				128-255	Reserved	
19	18	16	21		Rotating gobo wheel 1	
					<i>In the range of 0-59 DMX the gobo selection speed is controlled by the Effect Speed channel.</i>	
					<i>Index - set indexing on channel 20/19/17</i>	
				0-3	Open/hole	step
				4-7	Gobo 1	step
				8-11	Gobo 2	step
				12-15	Gobo 3	step
				16-19	Gobo 4	step
				20-23	Gobo 5	step
				24-27	Gobo 6	step
				28-31	Gobo 7	step
					<i>Rotation - set rotation on channel 20/19/17</i>	
				32-35	Gobo 1	step
				36-39	Gobo 2	step
				40-43	Gobo 3	step
				44-47	Gobo 4	step

DMX protocol

(For fixtures produced after 25/08/2013 or updated with a software DSU_RobinMMXSpot_13081343.zip (DSU_RobinMMXSpot_13081343.tar.bz2) or latter .

DSU RobinPointe_YYMMDDTT.zip -->YY=year, MM=month, DD= day.)

				48-51	Gobo 5	step
				52-55	Gobo 6	step
				56-59	Gobo 7	step
					<u>Shaking gobos from slow to fast</u>	
					<u>Index - set indexing on channel 20/19/17</u>	
				60 - 69	Gobo 1	proportional
				70 - 79	Gobo 2	proportional
				80 - 89	Gobo 3	proportional
				90 - 99	Gobo 4	proportional
				100 - 109	Gobo 5	proportional
				110 - 119	Gobo 6	proportional
				120 - 129	Gobo 7	proportional
					<u>Shaking gobos from slow to fast</u>	
					<u>Rotation - set rotation on channel 20/19/17</u>	
				130 - 139	Gobo 1	proportional
				140 - 149	Gobo 2	proportional
				150 - 159	Gobo 3	proportional
				160 - 169	Gobo 4	proportional
				170 - 179	Gobo 5	proportional
				180 - 189	Gobo 6	proportional
				190 - 199	Gobo 7	proportional
				200 - 201	Open/hole	step
				202 - 221	Forwards gobo wheel rotation from fast to slow	proportional
				222 - 223	No rotation	step
				224 - 243	Backwards gobo wheel rotation from slow to fast	proportional
				244 - 249	Random gobo selection by audio control	step
					(Set microphone sensitivity in menu „Personality“)	
				250 - 255	Auto random gobo selection from fast to slow	proportional
20	19	17	22		Rot. Gobo 1 indexing and rotation	
					<u>Gobo indexing - set position on channel 19/18/16</u>	
				0 - 255	Gobo indexing	proportional
					<u>Gobo rotation - set position on channel 19/18/16</u>	
				0	No rotation	step
				1 - 127	Forwards gobo rotation from fast to slow	proportional
				128 - 129	No rotation	step
				130 - 255	Backwards gobo rotation from slow to fast	proportional
21	*	*	23		Rot. Gobo 1 indexing/rotation - fine	
				0-255	Fine indexing (rotation)	proportional
22	20	18	24		Rotating gobo wheel 2	
					<i>In the range of 0-59 DMX the gobo selection speed is controlled by the Effect Speed channel.</i>	
					<u>Index - set indexing on channel 23/21/19</u>	
				0-3	Open/hole	step
				4-7	Gobo 1	step
				8-11	Gobo 2	step
				12-15	Gobo 3	step
				16-19	Gobo 4	step
				20-23	Gobo 5	step
				24-27	Gobo 6	step

DMX protocol

(For fixtures produced after 25/08/2013 or updated with a software DSU_RobinMMXSpot_13081343.zip (DSU_RobinMMXSpot_13081343.tar.bz2) or latter .

DSU RobinPointe_YYMMDDTT.zip -->YY=year, MM=month, DD= day.)

				28-31	Gobo 7	step
					Rotation - set rotation on channel 23/21/19	
				32-35	Gobo 1	step
				36-39	Gobo 2	step
				40-43	Gobo 3	step
				44-47	Gobo 4	step
				48-51	Gobo 5	step
				52-55	Gobo 6	step
				56-59	Gobo 7	step
					Shaking gobos from slow to fast	
					Index - set indexing on channel 23/21/19	
				60 - 69	Gobo 1	proportional
				70 - 79	Gobo 2	proportional
				80 - 89	Gobo 3	proportional
				90 - 99	Gobo 4	proportional
				100 - 109	Gobo 5	proportional
				110 - 119	Gobo 6	proportional
				120 - 129	Gobo 7	proportional
					Shaking gobos from slow to fast	
					Rotation - set rotation on channel 23/21/19	
				130 - 139	Gobo 1	proportional
				140 - 149	Gobo 2	proportional
				150 - 159	Gobo 3	proportional
				160 - 169	Gobo 4	proportional
				170 - 179	Gobo 5	proportional
				180 - 189	Gobo 6	proportional
				190 - 199	Gobo 7	proportional
				200 - 201	Open/hole	step
				202 - 221	Forwards gobo wheel rotation from fast to slow	proportional
				222 - 223	No rotation	step
				224 - 243	Backwards gobo wheel rotation from slow to fast	proportional
				244 - 249	Random gobo selection by audio control (Set microphone sensitivity in menu „Personality“)	step
				250 - 255	Auto random gobo selection from fast to slow	proportional
23	21	19	25		Rot. Gobo 2 indexing and rotation	
					Gobo indexing - set position on channel 22/20/18	
				0 - 255	Gobo indexing	proportional
					Gobo rotation - set position on channel 22/20/18	
				0	No rotation	step
				1 - 127	Forwards gobo rotation from fast to slow	proportional
				128 - 129	No rotation	step
				130 - 255	Backwards gobo rotation from slow to fast	proportional
24	*	*	26		Rot. Gobo 2 indexing/rotation - fine	
				0-255	Fine indexing (rotation)	proportional
25	22	20	27		Prism	
				0 - 19	Open position (hole)	step
				20 - 127	3-facet rotating prism	step
				128 - 255	Prism/gobo macros	
				128 - 135	Macro 1	step

DMX protocol

(For fixtures produced after 25/08/2013 or updated with a software DSU_RobinMMXSpot_13081343.zip (DSU_RobinMMXSpot_13081343.tar.bz2) or latter . DSU_RobinPointe_YYMMDDTT.zip -->YY=year, MM=month, DD= day.)						
				136 - 143	Macro 2	step
				144 - 151	Macro 3	step
				152 - 159	Macro 4	step
				160 - 167	Macro 5	step
				168 - 175	Macro 6	step
				176 - 183	Macro 7	step
				184 - 191	Macro 8	step
				192 - 199	Macro 9	step
				200 - 207	Macro 10	step
				208 - 215	Macro 11	step
				216 - 223	Macro 12	step
				224 - 231	Macro 13	step
				232 - 239	Macro 14	step
				240 - 247	Macro 15	step
				248 - 255	Macro 16	step
26	23	21	28		Prism rotation	
				0	No rotation	step
				1 - 127	Forwards rotation from fast to slow	proportional
				128 - 129	No rotation	step
				130 - 255	Backwards rotation from slow to fast	proportional
27	24	22	29		Frost	
				0	Open	step
				1 - 179	Frost from 0% to 100%	proportional
				180 - 189	100% frost	step
				190 - 211	Pulse closing from slow to fast	proportional
				212 - 233	Pulse opening from fast to slow	proportional
				234 - 255	Ramping from fast to slow	proportional
28	25	23	30		Iris	
				0	Open	step
				1 - 179	From max.diameter to min.diameter	proportional
				180 - 191	Closed	step
					Pulse effects with Iris blackout:	
				192 - 219	Pulse opening from slow to fast	proportional
				220 - 247	Pulse closing from fast to slow	proportional
				248 - 249	Random pulse opening (fast)	step
				250 - 251	Random pulse opening (slow)	step
				252 - 253	Random pulse closing (fast)	step
				254 - 255	Random pulse closing (slow)	step
29	*	*	31		Iris - fine	
				0 - 255	Fine iris movement	proportional
30	26	24	32		Zoom	
				0 - 255	Zoom from max. to min.beam angle	proportional
31	*	*	33		Zoom - fine	
				0-255	Fine zooming	proportional
32	27	25	34		Focus	
				0 - 255	Continuous adjustment from far to near	proportional
33	*	*	35		Focus - fine	
				0- 255	Fine focusing	proportional
34	28	26	36		Autofocus (priority & distance selection)	

DMX protocol

(For fixtures produced after 25/08/2013 or updated with a software DSU_RobinMMXSpot_13081343.zip (DSU_RobinMMXSpot_13081343.tar.bz2) or latter .

DSU RobinPointe_YYMMDDTT.zip -->YY=year, MM=month, DD= day.)

					Select desired distance and effect on which you need to focus and use "Focus" channel (32/27/25) to focus the image.	
				0	Autofocus Off	step
					Iris (hole)	
				1	4 metres	proportional
				8	7 metres	proportional
				16	10 metres	proportional
				24	15 metres	proportional
				32	20 metres	proportional
				40	30 metres	proportional
				48	40 metres	proportional
				56	50 metres	proportional
					Gobo wheel 1	
				64	4 metres	proportional
				72	7 metres	proportional
				80	10 metres	proportional
				88	15 metres	proportional
				96	20 metres	proportional
				104	30 metres	proportional
				112	40 metres	proportional
				120	50 metres	proportional
					Gobo wheel 2	
				128	4 metres	proportional
				136	7 metres	proportional
				144	10 metres	proportional
				152	15 metres	proportional
				160	20 metres	proportional
				168	30 metres	proportional
				176	40 metres	proportional
				184	50 metres	proportional
					Graphic wheel	
				192	4 metres	proportional
				200	7 metres	proportional
				208	10 metres	proportional
				216	15 metres	proportional
				224	20 metres	proportional
				232	30 metres	proportional
				240	40 metres	proportional
				248	50 metres	proportional
				255	Infinity	proportional
35	29	27	37		Hot-spot	
				0-255	Beam distribution control from max. intensity to min. intensity	proportional
36	30	28	38		Shutter/ strobe	
				0 - 31	Shutter closed, Lamp power reduced to 500 W	step
				32 - 63	Shutter open, Full lamp power	step
				64 - 95	Strobe-effect from slow to fast	proportional
				96 - 127	Shutter open, Lamp power reduced to 500 W	step
				128 - 143	Opening pulse in sequences from slow to fast	proportional
				144 - 159	Closing pulse in sequences from fast to slow	proportional

DMX protocol

(For fixtures produced after 25/08/2013 or updated with a software DSU_RobinMMXSpot_13081343.zip (DSU_RobinMMXSpot_13081343.tar.bz2) or latter . DSU RobinPointe_YYMMDDTT.zip -->YY=year, MM=month, DD= day.)						
				160 - 191	Shutter open, Electronic strobing „ZAP” from slow to fast	proportional
				192 - 223	Random strobe-effect from slow to fast	proportional
				224 - 255	Shutter open, Full lamp power	step
37	31	29	39		Dimmer intensity	
				0 - 255	Dimmer intensity from 0% to 100%	proportional
38	*	*	40		Dimmer intensity - fine	
				0 - 255	Fine dimming	proportional
** If some optic module (zoom, focus) has to move into anti-collision position before inserting frost or gobo, set time will be applied to both movements. E.g. Time = 5 sec. and the frost effect is to be inserted, but the zoom module has to move into anti-collision position before, this movement will take 5 sec. and after that movement of the frost module will take next 5 sec. To avoid this time delay, move the zoom module to anti-collision position before inserting the frost module.						

