

# RUSH MH 6 Wash

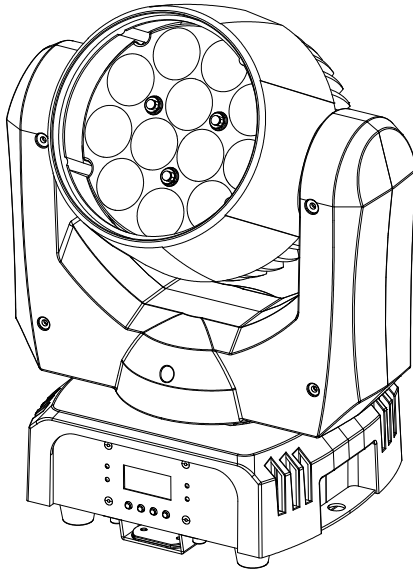

## User Manual



© 2015-2016 Martin Professional™ ApS. Information subject to change without notice. Martin Professional™ and all affiliated companies disclaim liability for any injury, damage, direct or indirect loss, consequential or economic loss or any other loss occasioned by the use of, inability to use or reliance on the information contained in this manual. Rush™, Martin™, Harman™ and all other trademarks in this document pertaining to services or products by Martin Professional™ or its affiliates and subsidiaries are registered as the property of Harman International Industries..

Martin Professional • Olof Palmes Allé 18 • 8200 Aarhus N • Denmark • [www.martin.com](http://www.martin.com)

RUSH MH 6 Wash User Manual: Revision D

# Table of contents

Safety information .....	4
Introduction .....	9
Before using the product for the first time .....	9
Physical installation .....	10
Fastening the fixture to a flat surface .....	10
Mounting the fixture on a truss .....	10
AC power .....	12
Linking fixtures to power in a chain .....	13
Fixture overview .....	14
Control data link .....	15
Tips for reliable data transmission .....	15
Connecting the data link .....	15
Fixture setup .....	16
Using the control menus .....	16
DMX addressing .....	16
Blackout or hold if DMX signal stops .....	16
Dimming curves .....	17
Dimmer speed .....	17
Pan/tilt inversion .....	18
Backlight .....	18
White balance adjustment .....	18
Cooling fan operation .....	19
Manual test .....	19
Auto test .....	19
Temperature .....	20
Fixture time .....	20
Reset .....	20
Home position (offsets) adjustment .....	20
Effects .....	22
Pan and tilt .....	22
Strobe effects .....	22
Electronic dimming .....	22
Color control .....	22
Maintenance .....	24
Cleaning .....	24
Replacing the primary fuse .....	25
Service and repairs .....	25
DMX protocol .....	26
Control menus .....	29
Troubleshooting .....	31
Specifications .....	32

# Safety information



## WARNING!

**Read the safety precautions in this manual before installing, operating or servicing this product.**

The following symbols are used to identify important safety information on the product and in this manual:



**Warning!**

***Safety hazard.  
Risk of severe  
injury or  
death.***



**Warning!**

***Powerful light  
emission. Risk  
of eye injury.***



**Warning!**

***See user  
manual for  
important  
safety  
information.***



**Warning!**

***Hazardous  
voltage. Risk  
of lethal or  
severe electric  
shock.***



**Warning!**

***Hot surfaces  
and fire  
hazard.***



Warning! Risk Group 2 product according to EN 62471. Possibly hazardous radiation emitted from this product. May be harmful to the eyes. Do not stare at operating lamp and do not view the light output with optical instruments or any device that may concentrate the beam.

This lighting fixture is for professional use only and must be installed by a qualified technician. It is not for household use. It presents risks of severe injury or death due to fire hazards, electric shock and falls. It produces a powerful, concentrated beam of light that can create a fire hazard or a risk of eye injury if the safety precautions below are not followed.



Install, operate and service RUSH by Martin™ products only as directed in their user manuals, or you may create a safety hazard or cause damage that is not covered by product warranties.

Follow the safety precautions listed below and observe all warnings in this manual and printed on the product. Keep this user manual for future use.

For the latest user documentation and other information for this and all Martin™ products, please visit the Martin website at <http://www.martin.com>

If you have any questions about how to install, operate or service the fixture safely, please contact your Martin™ distributor (see [www.martin.com/distributors](http://www.martin.com/distributors) for details) or call the Martin™ 24-hour service hotline on +45 8740 0000, or in the USA on 1-888-tech-180.

Respect all locally applicable laws, codes and regulations when installing, operating or servicing the fixture.



### **Protection from electric shock**

Do not expose the fixture to rain or moisture.

Disconnect the fixture from AC power before carrying out any installation or maintenance work and when the fixture is not in use.

Ensure that the fixture is electrically connected to ground (earth).

Use only a source of AC power that complies with local building and electrical codes and has both overload and ground-fault (earth-fault) protection.

Socket outlets or external power switches used to supply the fixture with power must be located near the fixture and easily accessible so that the fixture can easily be disconnected from power.

Replace defective fuses with ones of the specified type and rating only.

Isolate the fixture from power immediately if the power plug or any seal, cover, cable, or other component is damaged, defective, deformed, wet or showing signs of overheating. Do not reapply power until repairs have been completed

Before using the fixture, check that all power distribution equipment and cables are in perfect condition and rated for the electrical requirements of all connected devices.

Use only Neutrik PowerCon cable connectors to connect to the fixture's power sockets.

Do not connect devices to power in a chain that will exceed the electrical ratings of any cable or connector used in the chain.

The supplied power input cable is rated 6 A and can safely supply only one fixture with mains power. Do not connect any device to the fixture's MAINS OUT connector when using this cable. If you replace this cable and also use the replacement

cable to supply only one fixture with mains power, the replacement cable must also be rated 6 A minimum, have three conductors 18 AWG or 0.75 mm<sup>2</sup> minimum conductor size, have an outer cable diameter of 6 - 15 mm (0.2 - 0.6 in.) and be temperature-rated to suit the application. In the USA and Canada the cable must be UL listed, type SJT or equivalent. In the EU the cable must be type H05VV-F or equivalent.

To connect fixtures to mains power in a chain, you must first obtain 14 AWG or 1.5 mm<sup>2</sup> power input and throughput cables that are 16 A rated and temperature-rated to suit the application. In the USA and Canada the cables must be UL-listed, type SJT or equivalent. In the EU the cables must be type H05VV-F or equivalent. Suitable cables with Neutrik PowerCon connectors are available from Martin™ (see 'Accessories' on page 34). If you use these cables, you can connect fixtures to power in a linked chain, MAINS OUT throughput socket to MAINS IN input socket, but do not link more than:

- eight (8) RUSH MH 6 fixtures in total at 100-120 V, or
- fourteen (14) RUSH MH 6 fixtures in total at 200-240 V.

The voltage and frequency at the MAINS OUT socket are the same as the voltage and frequency applied to the MAINS IN socket. Only connect devices to the MAINS OUT socket that accept this voltage and frequency.



### **Protection from burns and fire**

Do not operate the fixture if the ambient temperature ( $T_a$ ) exceeds 40° C (104° F).

The surface of the product casing can reach up to 50° C (122° F) during operation. Avoid contact by persons and materials. Allow the fixture to cool for at least 10 minutes before handling.

Keep flammable materials well away from the fixture. Keep all combustible materials (e.g. fabric, wood, paper) at least 100 mm (4 in.) away from the fixture head.

Ensure that there is free and unobstructed airflow around the fixture. Provide a minimum clearance of 100 mm (4 in.) around fans and air vents.

Do not illuminate surfaces within 200 mm (8 in.) of the fixture.

Do not attempt to bypass thermostatic switches or fuses.

Connect only other fixtures of the same type to the power throughput sockets. Do not connect any other type of device to these sockets.

Do not stick filters, masks or other materials onto any optical component.

The fixture's lenses can focus the sun's rays inside the fixture, creating a risk of fire and damage. Do not expose the front of the fixture to sunlight or any other bright light source.



### **Protection from eye injury**

The light from the LED lamp is possibly hazardous and may be harmful to the eyes. Do not stare directly into the product's light output.

Do not look at the light output with magnifiers, telescopes, binoculars or similar optical instruments that may concentrate the light output.

Ensure that persons are not looking directly into the LEDs when the product lights up suddenly. This can happen when power is applied, when the product receives a DMX signal, or when certain control menu items are selected.

To minimize the risk of eye irritation or injury, disconnect the fixture from power at all times when the fixture is not in use, and provide well-lit conditions to reduce the pupil diameter of anyone working on or near the fixture.



### **Protection from injury**

Fasten the fixture securely to a fixed surface or structure when in use. The fixture is not portable when installed.

Ensure that any supporting structure and/or hardware used can hold at least 10 times the weight of all the devices they support.

If suspending from a rigging structure, fasten the fixture to a rigging clamp. Do not use safety cables as the primary means of support.

If the fixture is installed in a location where it may cause injury or damage if it falls, install as directed in this manual a secondary attachment such as a safety cable that will hold the fixture if a primary attachment fails. The secondary attachment must be approved by an official body such as TÜV as a safety attachment for the weight that it secures, must comply with EN 60598-2-17 Section 17.6.6 and must be capable of bearing a

static suspended load that is ten times the weight of the fixture and all installed accessories.

Allow enough clearance around the head to ensure that it cannot collide with an object or another fixture when it moves.

Check that all external covers and rigging hardware are securely fastened.

Block access below the work area and work from a stable platform whenever installing, servicing or moving the fixture.

Do not operate the fixture with missing or damaged covers, shields or any optical component.

Do not lift or carry the fixture by its head. Support the fixture by its base only.

In the event of an operating problem, stop using the fixture immediately and disconnect it from power. Do not attempt to use a fixture that is obviously damaged.

Do not modify the fixture in any way not described in this manual or install other than genuine RUSH by Martin™ parts.

Refer any service operation not described in this manual to a qualified technician.



# Introduction

The MH 6 Wash™ is a fast, powerful LED moving head wash effect incorporating twelve long-life LEDs with full RGBW color mixing and 36 color presets. The fixture also provides smooth electronic dimming, strobe effects, and a 10° - 60° zoom angle. It can be controlled by any DMX-compliant controller. The rugged, lightweight and compact fixture is suitable for both portable and fixed applications.

The fixture is supplied with this user manual, a 1.5 m (5 ft.) power cable (local power plug not included) and an omega-type mounting bracket for rigging clamp attachment.

## Before using the product for the first time

1. Read 'Safety information' on page 4 before installing, operating or servicing the fixture.
2. Unpack and ensure that there is no transportation damage before using the fixture. Do not attempt to operate a damaged fixture.
3. If the fixture is not going to be hard-wired to a mains supply, install a local power plug (not supplied) to the end of the supplied power cable.
4. Before operating, ensure that the voltage and frequency of the power supply match the power requirements of the fixture.
5. Check the RUSH support pages on the Martin Professional website at [www.martin.com](http://www.martin.com) for the most recent user documentation and technical information about the fixture. RUSH by Martin™ user manual revisions are identified by the revision letter at the bottom of the inside cover.

Note that whenever AC power is applied to the fixture, it will reset all effects and functions to their home positions. Be prepared for the fixture head to move. A reset usually takes around 20 seconds.

## Physical installation



**Warning! Read ‘Safety information’ on page 4 before installing the fixture.**

The fixture is designed for indoor use only and must be used in a dry location with adequate ventilation. Ensure that none of the fixture’s ventilation slots are blocked.

Fasten the fixture to a secure structure or surface. Do not stand it on a surface or leave it where it can be moved or fall over. If you install the fixture in a location where it may cause injury or damage if it falls, secure it as directed in this user manual using a securely anchored safety cable that will hold the fixture if the primary fastening method fails.

Martin™ can supply safety cables and rigging clamps that are suitable for use with the fixture (see ‘Accessories’ on page 34).

### Fastening the fixture to a flat surface

The fixture can be fastened to a hard, fixed, flat surface. Ensure that the surface and all fasteners used can support at least 10 times the weight of all fixtures and equipment they will support.

Fasten the fixture securely. Do not stand it on a surface or leave it where it can be moved or fall over. If you install the fixture in a location where it may cause injury or damage if it falls, secure it as directed below with a securely anchored safety cable that will hold the fixture if the primary fastening method fails.

### Mounting the fixture on a truss

The fixture can be clamped to a truss or similar rigging structure in any orientation. You must use a half-coupler clamp (see illustration on right) that completely encircles the truss chord.



To clamp the fixture to a truss:

1. Check that the rigging structure can support at least 10 times the weight of all fixtures and equipment to be installed on it.
2. Block access under the work area.
3. The fixture is supplied with an omega-type bracket to which a rigging clamp can be attached. Bolt a rigging clamp securely to the bracket. The bolt used must be M12, grade 8.8 steel minimum, and fastened with a self-locking nut.

4. Fasten the omega bracket to the base of the fixture using the bracket's quarter-turn fasteners. Turn quarter-turn fasteners a full 90° to lock them (see illustration on right).
5. Working from a stable platform, hang the fixture on the truss and fasten the rigging clamp onto the truss.
6. Secure the fixture with a safety cable as directed below.
7. Check that the head will not collide with other fixtures or objects.

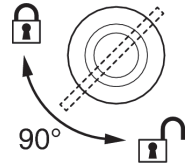

## Securing with a safety cable

Secure the fixture with a safety cable (or other secondary attachment) that is approved for the weight of the fixture so that the safety cable will hold the fixture if the primary attachment fails. See illustration on right. Loop the safety cable through the cutout in the fixture's baseplate (arrowed) and around a secure anchoring point.

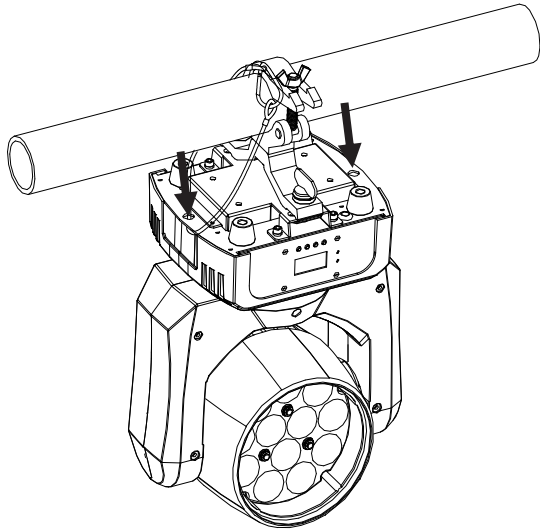

Martin™ can supply suitable safety cables and rigging clamps (see 'Accessories' on page 34).

## AC power



**Warning!** Read ‘Safety information’ on page 4 before connecting the fixture to AC mains power.



**Warning!** The mains power input cable supplied with the fixture is rated 6 A and can supply only one fixture with mains power. Do not connect any device to the fixture’s MAINS OUT power throughput socket when using this input cable. If you want to connect other fixtures to the MAINS OUT socket, see ‘Linking fixtures to power in a chain’ on page 13.

For protection from electric shock, the fixture must be grounded (earthed). The power distribution circuit must be equipped with a fuse or circuit breaker and ground-fault (earth-fault) protection.

Socket outlets or external power switches used to supply the fixture with power must be located near the fixture and easily accessible so that the fixtures can easily be disconnected from power.

Do not insert or remove live Neutrik PowerCon connectors to apply or cut power, as this may cause arcing at the terminals that will damage the connectors.

Do not use an external dimming system to supply power to the fixture, as this may cause damage to the fixture that is not covered by the product warranty.

The fixture can be hard-wired to a building electrical installation if you want to install it permanently, or a power plug (not supplied) that is suitable for the local power outlets can be installed on the power cable.

If you install a power plug on the power cable, install a grounding type (earthed) plug with integral cable grip that is rated minimum 250 V, 6 A. Follow the plug manufacturer’s instructions and connect the wires in the power cable as shown in this table:

	Live or L	Neutral or N	Earth, Ground or 
<b>US system</b>	Black	White	Green
<b>EU system</b>	Brown	Blue	Yellow/green

The fixture has an auto-ranging power supply that accepts AC mains power at 100-240 V at 50/60 Hz. Do not apply AC mains power at any other voltage or frequency to the fixture.

## Linking fixtures to power in a chain

If you obtain a 14 AWG / 1.5 mm<sup>2</sup> power input cable and 14 AWG / 1.5 mm<sup>2</sup> throughput cables from Martin™ (see 'Accessories' on page 34), you can relay mains power from one fixture to another by connecting fixtures to power in a linked daisy-chain, MAINS OUT throughput socket to MAINS IN input socket, Using 14 AWG or 1.5 mm<sup>2</sup> cables from Martin™, you can link:

- Maximum eight (8) RUSH MH 6 fixtures in total at 100-120 V, or
- Maximum fourteen (14) RUSH MH 6 fixtures in total at 200-240 V.

If you install a power plug on the 14 AWG / 1.5 mm<sup>2</sup> power cable, install a grounding type (earthed) plug with integral cable grip that is rated minimum 250 V, 16 A.

# Fixture overview

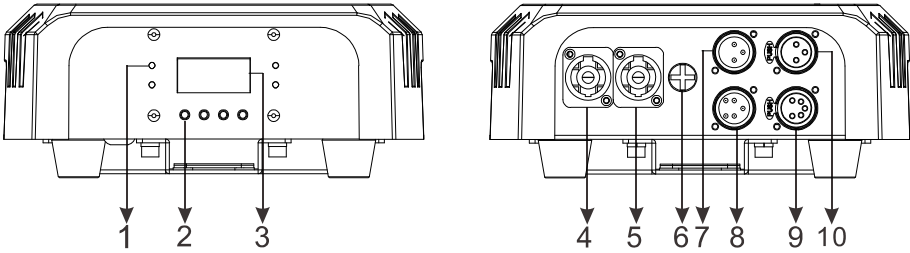

## 1 – LEDs

The LEDs on the front of the base give the following indications:

POWER	Power on
DMX	Valid DMX signal present

## 2 – Control buttons

MENU	<ul style="list-style-type: none"><li>• Activate the menu mode functions, or</li><li>• Return to the previous level of the menu structure, or</li><li>• Press and hold to exit the menus</li></ul>
DOWN	Go down a menu branch
UP	Go up a menu branch
ENTER	Confirm the selected function

## 3 – Display

### 4, 5 – AC mains power input / output

Use the blue Neutrik PowerCon socket to connect the fixture to mains power. Warning! The white Neutrik PowerCon socket can be used to supply power to other fixtures only if you respect the safety precautions given in this manual (see ‘Safety information’ on page 4).

### 6 – Primary (mains power) fuse

The T 3.15 A primary fuse (F1) is located inside the fuse holder.

### 7-10 – DMX input/output

3 and 5-pin XLR sockets are provided for DMX input and output (throughput).

## Control data link

A DMX 512 data link is required in order to control the fixture via DMX. The fixture has 3-pin and 5-pin XLR connectors for DMX data input and output.

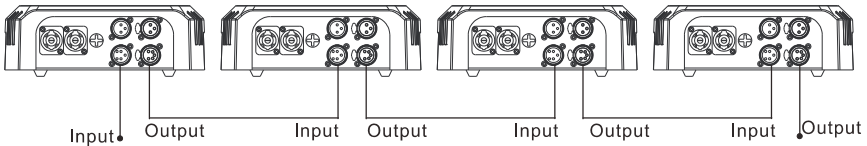

Up to 32 devices can be linked together on a single daisy chain. The total number of fixtures in one 512-channel DMX universe is limited by the number of DMX channels required by the fixtures. Note that if independent control of a fixture is required, it must have its own DMX channels. Fixtures that are required to behave identically can share the same DMX address and channels. To add more fixtures or groups of fixtures when the above limits are reached, add a DMX universe and/or split the daisy-chained link into branches.

### Tips for reliable data transmission

Use shielded twisted-pair cable designed for RS-485 devices: standard microphone cable cannot transmit control data reliably over long runs. 24 AWG cable is suitable for runs up to 300 meters (1000 ft.). Heavier gauge cable and/or an amplifier is recommended for longer runs. The pin-out on all connectors is pin 1 = shield, pin 2 = cold (-), and pin 3 = hot (+). Pins 4 and 5 in the 5-pin XLR connectors are not used in the fixture but are available for possible additional data signals as required by the DMX512-A standard. Standard pin-out is pin 4 = data 2 cold (-) and pin 5 = data 2 hot (+).

To split the link into branches, use a splitter such as the Martin 4-Channel Opto-Isolated RS-485 Splitter/Amplifier. Terminate the link by installing a termination plug in the output socket of the last fixture. The termination plug, which is a male XLR plug with a 120-Ohm, 0.25-Watt resistor soldered between pins 2 and 3, "soaks up" the control signal so it does not reflect and cause interference. If a splitter is used, terminate each branch of the link.

### Connecting the data link

To connect the fixture to data:

1. Connect the DMX data output from the controller to the closest fixture's male XLR DMX input connector.
2. Connect the first fixture's DMX output to the DMX input of the next fixture and continue connecting fixtures output to input. Terminate the last fixture on the link with a DMX termination plug.

## Fixture setup

This section explains the fixture characteristics that can be set that determine how it can be controlled and will behave. These settings are made using the menus available from the control panel, and are retained, even when the fixture is powered off.

Only the most commonly used menu options for fixture setup are described in this section. A complete map of the control menu structure and brief explanations of their purposes can be found on page 29.

### Using the control menus

To access the control menus, press the MENU button.

Navigate the menu structure using the ENTER, DOWN and UP buttons.

To select a menu option or to confirm a selection, press the ENTER button.

To return to a higher level in the menu structure without making a change, press the MENU button.

To exit the control menus completely, press and hold the MENU button.

### DMX addressing

The DMX address, also known as the start channel, is the first channel used to receive instructions from a DMX controller. The fixture is controlled using fourteen (14) DMX channels. Each DMX controlled fixture must have a DMX address set. For example, if a fixture has a DMX address of 10, then it uses channels 10, 11, 12, 13, 14, 15, 16, 17, 18, 19, 20, 21, 22, and 23. The following fixture in the DMX chain could then be set to a DMX address of 24.

For independent control, each fixture must be assigned its own control channels. Two fixtures of the same type may share the same address if identical behavior is desired. Address sharing can be useful for diagnostic purposes and symmetric control, particularly when combined with the inverse pan and tilt options.

To set the fixture's DMX address:

1. In the control menu, select DMX ADDRESS and press ENTER to confirm. The present address will blink in the display.
2. Use the UP and DOWN buttons to select the address (1 to 499).
3. Press ENTER to confirm your selection.

### Blackout or hold if DMX signal stops

To decide how the fixture behaves if the DMX signal is lost:

1. Select DMX STATE and press ENTER. The currently set mode will blink in the display.



2. Use the DOWN and UP buttons to select the behavior:
  - Select BLACKOUT if you want the fixture to black out if the DMX signal is lost.
  - Select HOLD if you want the fixture to continue showing the effect that it is displaying when the DMX signal is lost.
3. Press ENTER to save your selection.

## Dimming curves

Four dimming modes are available:

- MODE 1    LINEAR. The increase in light intensity appears to be linear as DMX value is increased.
- MODE 2    SQUARE LAW – light intensity control is finer at low levels and coarser at high levels.
- MODE 3    INVERSE SQUARE LAW – light intensity control is coarser at low levels and finer at high levels.
- MODE 4    S-CURVE – light intensity control is finer at low levels and high levels and coarser at medium levels.

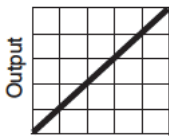

DMX %  
Optically linear

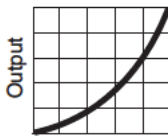

DMX %  
Square law

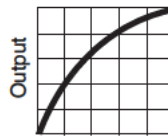

DMX %  
Inverse square law

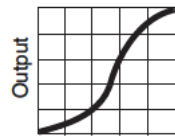

DMX %  
S-curve

To set the fixture's dimmer curve:

1. Select DIMMER CURVE and press ENTER to confirm. The mode that is currently active will blink in the display.
2. Use the DOWN and UP buttons to select MODE1, MODE2, MODE3 or MODE4.
3. Press ENTER to save your selection.

## Dimmer speed

There are two dimmer speed options:

- SNAP is the default setting. It sets the dimmer to exactly follow changes in dimming level sent from the controller. This gives the fastest dimmer response.
- FADE adds a two-second (approx.) smooth fade to changes in dimming level sent from the controller. This gives the smoothest dimmer fading.

To set the dimmer speed:

1. Select DIMMER SPEED and press ENTER to confirm.
2. Use the DOWN and UP buttons to select SNAP or FADE. Press ENTER to confirm.

## **Pan/tilt inversion**

The PAN INVERSE and TILT INVERSE menus can be used to reverse the direction of pan and tilt. These settings are useful for symmetrical effects with multiple fixtures, or when coordinating the movement of fixtures that are floor mounted and rigged upside down.

To adjust the pan inversion settings:

1. Select PAN INVERSE and press ENTER to confirm. The currently set mode will blink in the display.
2. Use the DOWN and UP buttons to select YES (tilt inversion) or NO (normal) mode.
3. Press ENTER to save your selection.

To adjust the tilt inversion settings:

1. Select TILT INVERSE and press ENTER to confirm. The currently set mode will blink in the display.
2. Use the DOWN and UP buttons to select YES (tilt inversion) or NO (normal) mode.
3. Press ENTER to save your selection.

## **Backlight**

To turn the control panel display backlight on or off:

1. Select BACK LIGHT and press ENTER to confirm. The present mode will blink in the display.
2. Use the DOWN and UP buttons to select ON or OFF.
3. Press ENTER to save your selection.

## **White balance adjustment**

To adjust the fixture's white balance:

1. Select WHITE BALANCE and press ENTER to confirm.
2. Use the DOWN and UP buttons to select RED, GREEN or BLUE.
3. Once the color has been selected, press ENTER.

4. Use the DOWN and UP buttons to adjust the amount of that color (125~255) in the white balance mix.
5. Press ENTER to save your selection.

## **Cooling fan operation**

There are two cooling fan options:

- AUTO is the default setting. It sets cooling fan speed to adjust automatically to regulate fixture temperature. This setting will allow the highest light output, but at high output levels in high ambient temperatures, cooling fan noise will be present.
- LOW sets cooling fan to constant low-speed operation. Fixture temperature is limited by adjusting light output if necessary. This setting will give the lowest cooling fan noise levels, but in high ambient temperatures light output will be reduced.

To set cooling fan operation:

1. Select FAN MODE and press ENTER to confirm.
2. Use the DOWN and UP buttons to select AUTO or SLOW. Press ENTER to confirm.

## **Manual test**

Fixture functions can be individually controlled and tested manually. This feature can be also used to set up a static scene without a controller. To operate the fixture effects manually:

1. Select MANUAL TEST and press ENTER.
2. Use the DOWN and UP buttons to select PAN, TILT, RED1, GREEN1, BLUE1, WHITE1...RED4, GREEN4, BLUE4, WHITE4, ZOOM, DIMMER or STROBE.
3. Once the mode has been selected, press ENTER.
4. Use the DOWN and UP button to change the value (0-255).
5. Press MENU to exit.

## **Auto test**

To perform a complete test of all fixture functions:

1. Select AUTO TEST and press ENTER. The fixture will run a self-test routine.
2. Press MENU to exit the test.

## Temperature

To check the onboard temperature of the fixture:

1. Select TEMP and press ENTER. The display will show the temperature of the unit.
2. Press MENU to exit.

## Fixture time

To display the fixture's operating hours counter:

1. Select FIXTURE TIME and press ENTER. The display will show the number of hours the fixture has been in operation since manufacture.
2. Press MENU to exit.

## Reset

The fixture resets each time you power it on, but you can also reset the fixture manually from the control panel and by DMX. To carry out a manual reset:

1. Scroll to RESET and press ENTER to reset the fixture (or press MENU to exit without resetting).
2. A reset takes approx. 20 seconds. After this, the fixture returns to its state before the reset.

## Home position (offsets) adjustment

If the fixture head or zoom angle do not return to their home positions, even after a reset, you can adjust their home positions by defining offsets.

To make the adjustment from the control menu:

1. In the menu structure, press and hold ENTER for at least 3 seconds to enter Offset mode.
2. Use the DOWN and UP buttons up to choose PAN OFFSET, TILT OFFSET, or ZOOM OFFSET. Press ENTER and the display will blink.
3. Use the DOWN and UP buttons to adjust the effect's home position.
4. Press ENTER to save your selection.

To make adjustments via DMX:

1. Select the fixture on the controller.
2. For each effect that requires calibration, enable calibration (DMX value 55-59) on the fixture's DMX channel 14, Fixture Control Settings.
3. Adjust zoom position on channel 9, pan position on channel 10, or tilt position on channel 12.

4. Store the effect's calibration value on DMX channel 14. Store zoom calibration with DMX value 230-234, pan calibration with DMX value 235-249, or tilt calibration with DMX value 240-244.
5. Repeat steps 2 – 4 as necessary.
6. When finished calibrating effects, set channel 14 to “No function” to resume normal DMX control.

# Effects

See 'DMX protocol' on page 26 for a full list of the DMX channels and values required to control the different effects.

## Pan and tilt

The fixture's head can be panned through 540° and tilted through 220°. Using the control menus it is possible to invert pan or tilt movement and enable or disable blackout during movement of the fixture head.

## Strobe effects

The strobe effects provide instant open and blackout, variable speed regular and random strobe.

## Electronic dimming

Overall intensity can be adjusted 0-100% using electronic dimming. Four different dimming curves are available (see 'Dimming curves' on page 17).

## Color control

DMX channels 4 – 7 provide full RGBW color mixing.

Besides color mixing, the MH 6 Wash™ provides a simulated color wheel effect with 36 preset colors that can be selected on channel 8. The simulated color wheel also provides variable speed color scrolling and random colors.

Note that DMX commands sent on DMX channel 8, the simulated color wheel, override DMX commands sent on individual RGBW color channels. For RGBW color control with DMX channels 4 – 7, the color wheel effect on channel 8 must be set to a DMX value from 0 to 10 (open position).

The 36 color presets are shown in the table below.

	Red	Green	Blue	White
<b>Color 1</b>	255	0	0	0
<b>Color 2</b>	255	155	0	0
<b>Color 3</b>	255	190	0	170
<b>Color 4</b>	255	225	0	0
<b>Color 5</b>	255	245	0	0
<b>Color 6</b>	255	253	0	202
<b>Color 7</b>	255	255	0	0
<b>Color 8</b>	245	255	0	0
<b>Color 9</b>	226	255	0	124

	<b>Red</b>	<b>Green</b>	<b>Blue</b>	<b>White</b>
<b>Color 10</b>	205	255	0	0
<b>Color 11</b>	165	255	0	195
<b>Color 12</b>	0	255	0	0
<b>Color 13</b>	0	255	155	0
<b>Color 14</b>	0	255	185	70
<b>Color 15</b>	0	255	210	0
<b>Color 16</b>	0	255	230	0
<b>Color 17</b>	0	255	240	100
<b>Color 18</b>	0	255	255	0
<b>Color 19</b>	0	250	255	0
<b>Color 20</b>	0	220	255	160
<b>Color 21</b>	0	215	225	0
<b>Color 22</b>	0	190	255	190
<b>Color 23</b>	0	0	255	0
<b>Color 24</b>	165	0	255	0
<b>Color 25</b>	195	0	255	0
<b>Color 26</b>	225	0	255	0
<b>Color 27</b>	240	0	255	170
<b>Color 28</b>	253	0	255	0
<b>Color 29</b>	255	0	255	0
<b>Color 30</b>	255	0	245	0
<b>Color 31</b>	255	0	235	0
<b>Color 32</b>	255	0	220	0
<b>Color 33</b>	255	0	185	185
<b>Color 34</b>	255	0	165	0
<b>Color 35</b>	0	0	0	255
<b>Color 36</b>	255	255	255	255

# Maintenance



**Warning! Read ‘Safety information’ on page 4 before servicing the fixture.**

Refer any service operation not described in this user manual to a qualified service technician.

Disconnect the fixture from mains power before cleaning or servicing.

Service fixtures in an area where there is no risk of injury from failing parts, tools or other materials.

The user may carry out the service operations described in this manual. All other service operations must be carried out by an authorized Martin™ service technician. Do not try to repair the fixture yourself, as you may create a safety risk or cause damage that is not covered by the product warranty.

Installation, on-site service and maintenance can be provided worldwide by the Martin Professional™ Global Service organization and its approved agents, giving owners access to Martin’s expertise and product knowledge in a partnership that will ensure the highest level of performance throughout the product’s lifetime. Please contact Martin™ for details.

## Cleaning

Excessive dust, smoke fluid, and particle buildup degrades performance, causes overheating and will damage the fixture. Damage caused by inadequate cleaning or maintenance is not covered by the product warranty.

The cleaning of external optical lenses must be carried out periodically to optimize light output. Cleaning schedules for lighting fixtures vary greatly depending on the operating environment. It is therefore impossible to specify precise cleaning intervals for the fixture. Environmental factors that may result in a need for frequent cleaning include:

- Use of smoke or fog machines.
- High airflow rates (near air conditioning vents, for example).
- Presence of cigarette smoke.
- Airborne dust (from stage effects, building structures and fittings or the natural environment at outdoor events, for example).

If one or more of these factors is present, inspect fixtures within their first 100 hours of operation to see whether cleaning is necessary. Check again at frequent intervals. This procedure will allow you to assess cleaning requirements in your particular situation. If in doubt, consult your RUSH by Martin dealer about a suitable maintenance schedule.



Use gentle pressure only when cleaning, and work in a clean, well-lit area. Do not use any product that contains solvents or abrasives, as these can cause surface damage.

To clean the fixture:

1. Disconnect the fixture from power and allow it to cool for at least 10 minutes.
2. Vacuum or gently blow away dust and loose particles from the outside of the fixture and the air vents at the back and sides of the head and in the base with low-pressure compressed air.
3. Clean surfaces by wiping gently with a soft, clean lint-free cloth moistened with a weak detergent solution. Do not rub glass surfaces hard: lift particles off with a soft repeated press. Dry with a soft, clean, lint-free cloth or low-pressure compressed air. Remove stuck particles with an unscented tissue or cotton swab moistened with glass cleaner or distilled water.
4. Check that the fixture is dry before reapplying power.

## **Replacing the primary fuse**

If the fixture is completely dead, the fixture's primary fuse F1 may have blown and it may be necessary to install a new fuse. This fuse is located in a fuseholder next to the MAINS IN and OUT sockets on the connections panel. See 'Fixture overview' on page 14.

If you need to replace a fuse:

1. Disconnect the fixture from power and allow it to cool for at least 10 minutes.
2. Unscrew the cap of the fuseholder and remove the fuse. Replace with a fuse of the same size and specified rating only.
3. Reinstall the fuseholder cap before reapplying power.

## **Service and repairs**

There are no user serviceable parts inside the fixture. Do not open the housing.

Never try to repair the fixture by yourself as this may result in damage or malfunction and it may potentially void your product warranty. The equipment must only be serviced or repaired by an authorized RUSH by Martin service technician.

# DMX protocol

DMX	Value	Function	Fade type	Default
1	<b>Strobe and Pulse effects</b>		Snap	12
	0-7	Off		
	8-15	Open		
	16-131	Strobe, slow to fast		
	132-139	Open		
	140-181	Pulse, fast close & slow open		
	182-189	Open		
	190-231	Pulse, fast open & slow close		
	232-239	Open		
	240-247	Strobe random		
	248-255	Open		
2	0-255	<b>Dimming Coarse</b> 0 → 100%	Fade	0
3	0-255	<b>Dimming Fine</b>	Fade	0
4	0-255	<b>Red</b> 0 → 100%	Fade	0
5	0-255	<b>Green</b> 0 → 100%	Fade	0
6	0-255	<b>Blue</b> 0 → 100%	Fade	0
7	0-255	<b>White</b> 0 → 100%	Fade	0
8	<b>“Color Wheel” Effect (Color Presets)</b>		Snap	0
	0-10	Open		
	11-15	Color 1		
	16-20	Color 2		
	21-25	Color 3		
	26-30	Color 4		
	31-35	Color 5		
	36-40	Color 6		
	41-45	Color 7		
	46-50	Color 8		
	51-55	Color 9		
	56-60	Color 10		
	61-65	Color 11		
	66-70	Color 12		
	71-75	Color 13		
	76-80	Color 14		
	81-85	Color 15		
	86-90	Color 16		
	91-95	Color 17		
96-100	Color 18			
101-105	Color 19			

DMX	Value	Function	Fade type	Default
8	106–110	Color 20	Snap	0
	111–115	Color 21		
	116–120	Color 22		
	121–125	Color 23		
	126–130	Color 24		
	131–135	Color 25		
	136–140	Color 26		
	141–145	Color 27		
	146–150	Color 28		
	151–155	Color 29		
	156–160	Color 30		
	161–165	Color 31		
	166–170	Color 32		
	171–175	Color 33		
	176–180	Color 34		
	181–185	Color 35		
	186–190	Color 36		
	191–192	Open		
		Color Scroll		
	193–214	Ascending, fast → slow		
215–221	Stop (at current position)			
222–243	Descending, slow → fast			
	Random Slots			
244–247	Fast			
248–251	Medium			
252–255	Slow			
9	0–255	<b>Zoom</b> wide → narrow	Fade	128
10	0–255	<b>Pan</b> 0° → 540°	Fade	128
11	0–255	<b>Pan</b> (fine control)	Fade	128
12	0–255	<b>Tilt</b> 0° → 220°	Fade	128
13	0–255	<b>Tilt</b> (fine control)	Fade	128
14	<b>Fixture Control Settings</b>		Snap	0
	0–9	No function (disables calibration)		
	10–14	Reset fixture		
	15–54	No function		
	55–59	Enable calibration		
	60–74	No function		
	75–79	Pan & Tilt Speed = Normal		
	80–89	Pan & Tilt Speed = Fast (default)		
	90–94	Pan & Tilt Speed = Slow		

<b>DMX</b>	<b>Value</b>	<b>Function</b>	<b>Fade type</b>	<b>Default</b>
14	95–144	No function	Snap	0
	145–149	Pan/tilt blackout = ON		
	150–154	Pan/tilt blackout = OFF		
	155–159	Illuminate display		
	160–164	Display illumination off		
	165–229	No function		
	230–234	Store zoom calibration		
	235–239	Store pan calibration		
	240–244	Store tilt calibration		
	245–249	Reset all calibrations to factory default		
	250–255	No function		

## Control menus

To access the control menus, press the MENU button. Use the UP and DOWN buttons to navigate the menus. Select a menu option with the ENTER button. For more information, see 'Using the control menus' on page 16.

Default fixture settings are shown in **bold**.

Menu	Sub-menu	Explanation
DMX Address	001–512	Fixture DMX address setting
Dimmer Curve	<b>Mode 1</b>	Optically linear
	Mode 2	Square law
	Mode 3	Inverse square law
	Mode 4	S-curve
Pan Inverse	Yes	Invert pan control
	<b>No</b>	Normal pan control
Tilt Inverse	Yes	Invert tilt control
	<b>No</b>	Normal tilt control
Back light	On	Control panel display backlight on
	<b>Off</b>	Display backlight off
Dimmer Speed	Fade	Optimize dimmer for smoothness
	<b>Snap</b>	Optimize dimmer for speed
DMX State	<b>Blackout</b>	If no DMX signal received, fixture blacks out
	Hold	If no DMX signal, fixture remains in the state it was last in when receiving DMX
Fan Mode	<b>Auto</b>	Set cooling fan operating mode
	Low	
White Balance	Red (125...255)	Adjust white balance red mix
	Green (125...255)	Adjust white balance green mix
	Blue (125...255)	Adjust white balance blue mix

Manual Test	Pan (0...255)	Manual control of pan
	Tilt (0...255)	Manual control of tilt
	Red (0...255)	Manual control of red
	Green (0...255)	Manual control of green
	Blue (0...255)	Manual control of blue
	White (0...255)	Manual control of white
Manual Test	Zoom (0...255)	Manual control of zoom
	Dimmer (0...255)	Manual control of dimmer
	Strobe (0...255)	Manual control of strobe
Auto test		Automatic test of all functions
Temp.		Temperature of onboard sensor
Fixture Time		Fixture operating hours counter
Firmware Version		Currently installed firmware version
PRO Defaults	<b>No</b>	Keep user settings
	Yes	Restore factory default settings
Reset		Reset fixture

To access the Offset menu, press MENU to enter the menu structure and then press and hold ENTER for three seconds.

Menu	Sub-menu	Explanation
Offset	Pan offset (-127...127)	Adjust home pan position
	Zoom offset (0...255)	Adjust home zoom position
	Tilt offset (-127...127)	Adjust home tilt position

# Troubleshooting

This section describes a few common problems that may occur during operation and provides some suggestions for easy troubleshooting:

Symptom	Potential Causes	Remedies
No light from fixture, or fans not working.	Power supply issue such as blown fuse, faulty connector or damaged cable.	<p>Ensure that the mains supply is connected and supplying power to the fixture.</p> <p>Check all power connections and cables.</p> <p>Check and if necessary replace the fixture fuse.</p>
One of the control channels is unresponsive or only responds intermittently.	<p>DMX setup or DMX link fault.</p> <p>Damaged step motor or cable connection between head and body.</p>	<p>See next section.</p> <p>Contact your RUSH by Martin authorized distributor or service center for assistance.</p>
Fixture does not respond to DMX control.	Fault in the DMX network due to connector or cable damage, incorrect DMX addressing, or potential interference from proximity to a high voltage installation.	<p>Ensure that fixture's DMX address matches address set on DMX control device.</p> <p>Check that fixture DMX LED is on, and if not, check all DMX cables and connections.</p> <p>Ensure that DMX link is terminated.</p> <p>Check that all components on DMX link use standard DMX polarity.</p> <p>Attempt to control the fixture with another DMX control device.</p> <p>Move or shield link if it is close to an unshielded high-voltage installation.</p>

# Specifications

## Physical

Dimensions (LxWxH).....290 x 189 x 360 mm (11.4 x 7.4 x 14.2 in.)  
Weight .....7.1 kg (15.7 lbs.)

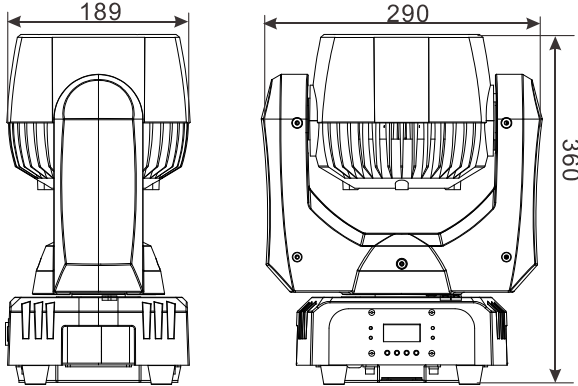

## Dynamic Effects

Color mixing..... RGBW  
Color presets ..... 36 color presets plus full white, 'color wheel' effects  
Electronic dimming ..... 0 - 100%, four dimming curve options  
Strobe and pulse effects..... Variable speed and action, random strobe  
Electronic 'shutter' effect ..... Instant open and blackout  
Zoom ..... Motorized, 10 - 60°  
Pan ..... 540°  
Tilt..... 220°

## Optics

Light source ..... 12 x 10 W RGBW Osram Ostar LEDs  
Minimum LED lifetime ..... 50 000 hours (to >70% luminous output)\*  
Beam angle ..... 10° - 60°  
*\*Figure obtained under manufacturer's test conditions*

## Control and Programming

Control options .....DMX  
DMX channels ..... 14  
White balance control..... RGB adjustment  
16-bit fine control..... Dimming, pan and tilt  
DMX address setting ..... Control panel with LCD display  
Protocol ..... USITT DMX512/1990

## Construction

Housing .....High impact flame retardant thermoplastic  
Color .....Black



Ingress protection rating..... IP 20

### Installation

Mounting points..... One quarter-turn bracket for rigging clamp  
Location..... Indoor use only, must be fastened to surface or structure  
Orientation..... Any  
Minimum distance to illuminated surfaces ..... 200 mm (8 in.)  
Minimum distance to combustible materials ..... 100 mm (4 in.)  
Minimum clearance around fans and vents ..... 100 mm (4 in.)

### Connections

AC power in/thru..... Neutrik PowerCON  
DMX data in/thru ..... 3-pin & 5-pin locking XLR

### Electrical

AC power..... 100-240 V nominal, 50/60 Hz  
Power supply unit..... Auto-ranging electronic switch mode  
Fuse ..... T 3.15 A  
Recommended Miniature Circuit Breaker\* ..... Type D  
\*Per IEC 60898/UL489/CSA C22.2 No. 5

### Typical power and current

120 V, 60 Hz..... 1.3 A, 155 W, PF 0.99  
230 V, 50 Hz..... 0.7 A, 155 W, PF 0.94  
Typical half-cycle RMS inrush current at 240 VAC ..... 11.3 A  
*Measurements made at nominal voltage with all LEDs at full intensity. Allow for a deviation of +/- 10%.*

### Thermal

Cooling ..... Forced air (temperature regulated, low noise)  
Maximum ambient temperature (T<sub>a</sub> max.)..... 40° C (104° F)  
Minimum ambient temperature (T<sub>a</sub> min)..... 0° C (32° F)

### Approvals



EU safety..... EN 60598-2-17 (EN 60598-1), EN 62471, EN 62493  
EU EMC ..... EN 55015, EN 55032, EN 55103-2, EN 61000-3-2,  
EN 61000-3-3, EN 61547  
US safety..... UL 1573, UL 8750  
US EMC ..... FCC Part 15  
Canadian safety ..... CSA C22.2 No. 166  
Australia/NZ..... C-TICK N4241 / RCM

**Included Items**

- Power cable, 6 A, 18 AWG, 0.75 mm<sup>2</sup>, UL- listed, H05VV-F, 1.5 m, without mains plug
- Omega bracket for rigging clamp attachment

**Accessories**

*Cables, 16 A, for connection to power in chains*

- Power input cable, 14 AWG, SJT, 1.5 mm<sup>2</sup>, H05VV-F, UL, with PowerCon input connector, 3 m (9.8 ft.) ..... P/N 11541508
- Power relay cable, 14 AWG, SJT, 1.5 mm<sup>2</sup>, H05VV-F, UL, with PowerCon connectors, 1.4 m (4.6 ft.) ..... P/N 11541509
- Power relay cable, 14 AWG, SJT, 1.5 mm<sup>2</sup>, H05VV-F, UL, with PowerCon connectors, 2.25 m (7.4 ft.) ..... P/N 11541510
- Power relay cable, 14 AWG, SJT, 1.5 mm<sup>2</sup>, H05VV-F, UL, with PowerCon connectors, 3.25 m (10.7 ft.) ..... P/N 11541511

*Power connectors*

- Neutrik PowerCon NAC3FCA power input connector, cable mount, blue ..... P/N 05342804
- Neutrik PowerCon NAC3FCB power output connector, cable mount, light grey ..... P/N 05342805

*Installation hardware*

- Half-coupler clamp ..... P/N 91602005
- G-clamp ..... P/N 91602003
- Quick-trigger clamp ..... P/N 91602007
- Safety cable, safe working load 50 kg..... P/N 91604003
- DMX termination plug, 3-pin male XLR..... P/N 91613017

**Related Items**

- RUSH Software Uploader 1™ ..... P/N 91611399

**Ordering Information**

- RUSH MH 6 Wash™ in cardboard box..... P/N 90280080

*Specifications subject to change without notice. For latest product specifications, see [www.martin.com](http://www.martin.com)*

	<p><b>Disposing of this product</b></p> <p>Martin™ products are supplied in compliance with Directive 2012/19/EC of the European Parliament and of the Council of the European Union on WEEE (Waste Electrical and Electronic Equipment), where applicable. Help preserve the environment! Ensure that this product is recycled at the end of its life. Your supplier can give details of local arrangements for the disposal of Martin products</p>
--	--

## Photobiological Safety Warning

The label shown below is displayed on this product. If it becomes difficult or impossible to read, it must be replaced using the illustration below to reproduce a new label sized 45 x 18 mm, in black on a yellow background.

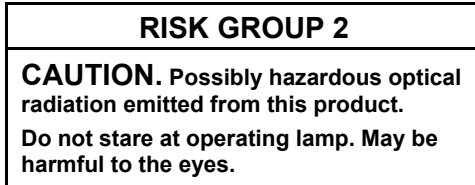

**RUSH**™  
by Martin®