

martinarchitectural

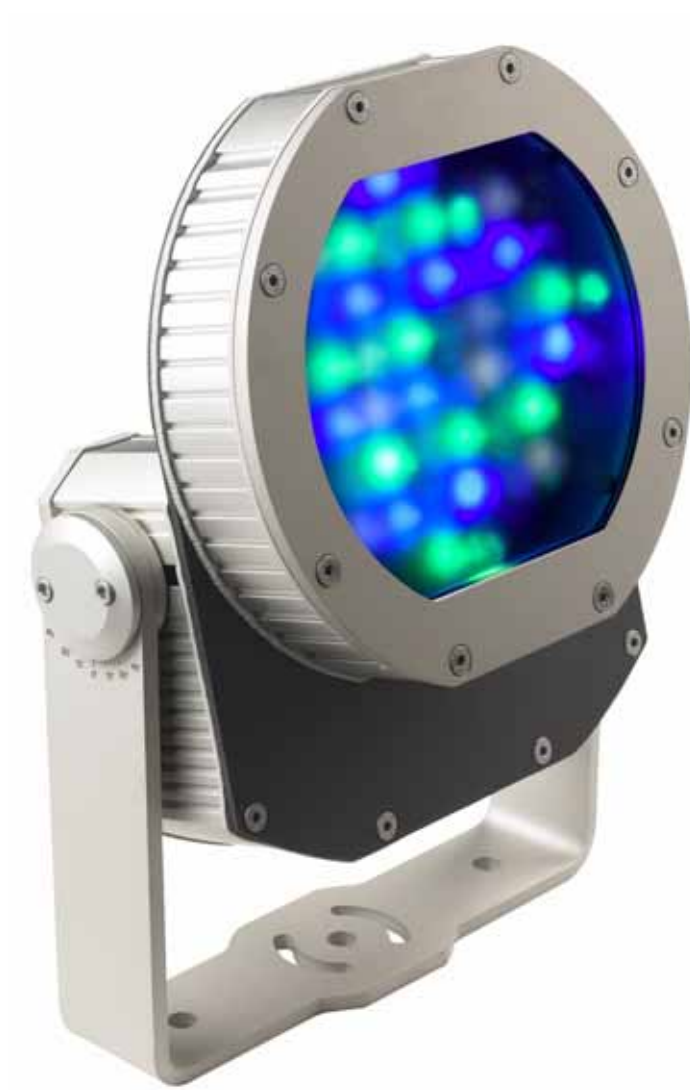

# Exterior 200 LED™ user manual

**Martin**

# Dimensions

All dimensions are in millimeters

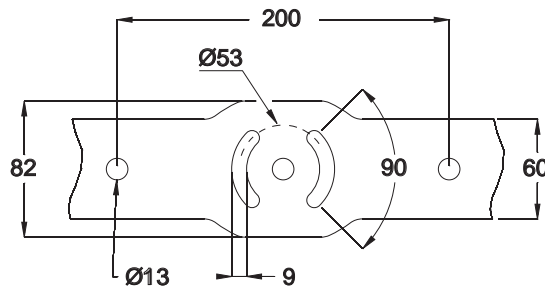
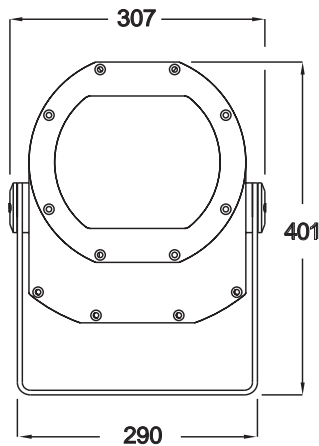
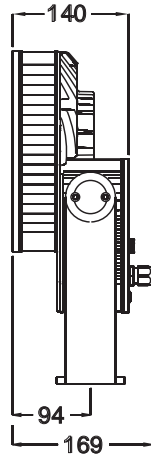

---

©2007-2009 Martin Professional A/S. Information subject to change without notice. Martin Professional A/S and all affiliated companies disclaim liability for any injury, damage, direct or indirect loss, consequential or economic loss or any other loss occasioned by the use of, inability to use or reliance on the information contained in this manual. The Martin logo, the Martin name and all other trademarks in this document pertaining to services or products by Martin Professional A/S or its affiliates and subsidiaries are trademarks owned or licensed by Martin Professional A/S or its affiliates or subsidiaries. The use of certain patents in Martin Exterior 200 LED products is licensed by Color Kinetics, Inc. (see details printed on product).

P/N 35000211, Rev. E

---

# Safety Information



## WARNING!

**Read the safety precautions in this section before installing, powering, operating or servicing this product.**

The following symbols are used to identify important safety information on the product and in this manual:



**DANGER!**  
Safety hazard.  
Risk of severe injury or death.



**Warning!**  
Hazardous voltage. Risk of lethal or severe electric shock.



**Warning!**  
LED light emission. Risk of eye injury.



**Warning!**  
Fire hazard.



**Warning!**  
Refer to user manual.



**Warning! Class 3B LED product. Do not look into the beam at a distance of less than 2.2 meters (7 feet 3 inches) from the front surface of the product. Do not view the light output with optical instruments or any device that may concentrate the beam.**



This product is for professional use only. It is not for household use.

This product presents risks of severe injury or death due to fire hazards, electric shock and falls.



**Read this manual** before installing, powering or servicing the fixture, follow the safety precautions listed below and observe all warnings in this manual and printed on the fixture. Install and operate the fixture only as described in this manual and in accordance with local laws and regulations. Refer any operation not described in this manual to a qualified technician. If you have questions about how to operate the fixture safely, please contact your Martin dealer or call the Martin 24-hour service hotline at +45 70 200 201.



## PROTECTION FROM ELECTRIC SHOCK

- Shut down power to the entire installation at the main power distribution board and lock out power (by removing the fuse for example) before carrying out any installation or maintenance work.
- Disconnect the fixture from AC power before removing or installing any cover or part and when not in use.
- Connect the fixture electrically to ground (earth).
- Use only a source of AC power that complies with local building and electrical codes and has both overload and ground-fault (earth-fault) protection.
- Connect the fixture to AC power either using either the supplied power cable or a listed 3-conductor Hypalon or neoprene rubber-jacket cable rated to 90° C (194° F) minimum and with conductor size 1.5 mm<sup>2</sup> or 16 AWG minimum.
- Before using the fixture, check that all power distribution equipment and cables are in perfect condition, are rated for the current requirements of all connected devices, are protected to IP67 or higher and are of suitable type for the location (including water, pollution, temperature and UV resistance).
- Isolate the fixture from power immediately if any cable, seal, cover or other component is damaged, cracked or deformed. Do not reapply power until repairs have been completed.

- Do not expose any part of the fixture to a high-pressure water jet.
- Do not immerse the fixture in water or any other fluid, or install it in a location where flooding may occur.
- Refer any service operation not described in this manual to an authorized Martin Service partner.

## PROTECTION FROM BURNS AND FIRE



- Do not operate the fixture if the ambient temperature ( $T_a$ ) exceeds 45° C (113° F).
- The exterior of the fixture becomes hot, up to 90° C (194° F) during normal operation. Ensure that accidental physical contact with a hot fixture is impossible.
- Allow the fixture to cool for 20 minutes before servicing.
- Do not illuminate surfaces less than 0.1 m (4 in.) from the front surface of the fixture.
- Keep flammable materials well away from the fixture.
- Do not modify the fixture in any way not described in this manual or install other than genuine Martin parts. Do not stick filters, masks or other materials directly onto LEDs. Use only Martin approved accessories to mask or modify the light beam.
- Do not attempt to bypass thermostatic switches or fuses. Replace defective fuses with ones of the specified type and rating only.
- Install the fixture outdoors or in a well-ventilated area only. Provide a minimum clearance of 150 mm (6 in.) and ensure unrestricted airflow around the fixture.
- Provide a minimum center-to-center distance of 550 mm (21.7 in.) between Exterior 200 LED fixtures.

## PROTECTION FROM INJURY



- Do not look at LEDs from a distance of less than 2.2 meters (7 feet 3 inches) from the front surface of the fixture without suitable protective eyewear. At less than this distance, the LED emission can cause eye injury or irritation. At distances of 2.2 meters (7 feet 3 inches) and above, light output is harmless to the naked eye.
- Do not look at LEDs with magnifiers or similar optical instruments that may concentrate the light output.
- Ensure that all external covers, components and installation fittings are securely fastened.
- Block access below the work area and work from a stable platform whenever installing, servicing or moving the fixture.
- Ensure that all supporting structures, surfaces, fasteners and lifting equipment can bear the weight of all the devices they are intended to support plus an adequate safety margin, and that they conform to local building and safety regulations.
- Use a sufficient number of fasteners with sufficient corrosion resistance, dimensions and strength to mount the fixture safely. Any nuts used must be self-locking. Washers must be installed directly under the fasteners' heads when anchoring the yoke base to the installation surface.



### Disposing of this product

Martin™ products are supplied in compliance with Directive 2002/96/EC of the European Parliament and of the Council of the European Union on WEEE (Waste Electrical and Electronic Equipment), as amended by Directive 2003/108/EC, where applicable.

Help preserve the environment! Ensure that this product is recycled at the end of its life. Your supplier can give details of local arrangements for the disposal of Martin products.

# Contents

Dimensions .....	2
Safety Information .....	3
Introduction .....	7
Unpacking .....	7
Using for the first time .....	7
Physical installation .....	8
Location and orientation .....	8
Mounting fasteners .....	8
Tilt adjustment .....	9
Power and DMX data cable layout .....	10
AC power .....	11
Connecting to power .....	11
Replacing the power cable .....	12
Control data link .....	14
Connecting the data link .....	15
Fixture setup .....	16
Setting up a fixture with a PC and MUM .....	16
Operation .....	19
DMX control .....	19
Stand-alone operation .....	19
Service and maintenance .....	25
Cleaning .....	25
Installing and removing a diffuser filter .....	26
Fuse replacement .....	27
Fixture readouts in MUM .....	27
Software installation .....	27
Status indicators .....	28
DMX protocols .....	30
RGB Mode .....	30
RGBAW Mode .....	30
HSI Mode .....	30
HSIC Mode .....	31
Troubleshooting .....	32
Specifications .....	33

# Notes

# Introduction

Thank you for selecting the Exterior 200 LED™, a compact LED-based color-changing floodlight from Martin™. This product features:

- Luxeon K2 high-power LEDs
- 1400 lm total LED output per fixture (balanced white 5600 K at 25° C / 77° F)
- RGBAW (red, green, blue, amber, white), and RGB color mixing, HSIC (hue, saturation, intensity, color temperature) and HSI color management
- Diffuser filters for alternative spread angles
- 21° viewing angle (with narrow diffuser)
- DMX 512A control (3 - 5 channels depending on control mode)
- Remote configuration and addressing over the DMX data link using MUM software and a hardware interface
- Auto-sensing power supply unit with 100 - 240 V, 50/60 Hz operating range

For the latest firmware updates, documentation, product specifications and other information about this and all Martin Professional™ products, please visit the Martin website at <http://www.martin.com>

Comments or suggestions regarding this document may be e-mailed to [service@martin.dk](mailto:service@martin.dk) or posted to:

Service Department  
Martin Professional A/S  
Olof Palmes Allé 18  
DK-8200 Aarhus N  
Denmark

## Unpacking

The following items are included with the Exterior 200 LED:

- Adjustable mounting bracket
- Narrow diffuser filter (installed)
- Medium and Wide diffuser filters (supplied separately)
- This user manual

## Using for the first time

Before applying power to the fixture:

- Carefully review "Safety Information" on page 3.
- Check that the local AC power voltage is within the range listed on the fixture's serial number label.
- Install the fixture as described in this manual

# Physical installation



**Warning!** Read "Safety Information" on page 3 before installing the Exterior 200 LED.

**Warning!** The safety and suitability of lifting equipment, installation location, anchoring method, mounting hardware and electrical installation is the responsibility of the installer. All local safety regulations and legal requirements must be observed when installing and connecting the Exterior 200 LED. Installation must be carried out by qualified professionals only.

Contact your Martin Architectural™ supplier for assistance if you have any questions about how to install this product safely.

## Location and orientation



**Warning!** The Exterior 200 LED mounting yoke base must be securely anchored to a suitable flat surface. Ensure that the supporting structure can bear the weight of all installed devices plus an adequate safety margin.

**Warning!** If no diffuser filter is installed, make sure that it is impossible for LEDs to be viewed from a distance of less than 2.2 meters (7 feet 3 inches).



If the diffuser front is installed, there is no eye hazard at any distance.

**important!** Make sure that there will be at least 0.1 m (4 in.) of free space and unrestricted airflow around the fixture.

Allow for service access to the front and rear of the fixture.

The Exterior 200 LED can be installed outdoors. It has an IP rating of 65 and is designed to withstand rain and other low-pressure water projections but:

- Do not expose it to high-pressure water jets from any direction
- Do not immerse it in water (or any other fluid)
- Do not install it in a location where flooding may occur.

Ensure sufficient drainage to cope with the heaviest rainfall. Make sure that water can drain away from the installation area at least as fast as it can enter it.

The Exterior 200 LED requires free and unobstructed airflow around it to ensure adequate cooling:

- Do not bury the fixture or locate it in an unventilated space
- Allow 0.1 m (4 in.) free space around the fixture

Install the fixture at least 0.5 m (20 in.) away from any combustible materials (wood, paper, etc.) and well away from any flammable materials.

The aluminum housing reaches temperatures up to 90° C (194° F). Restrict public access or locate the fixture so that it cannot accidentally be touched.

## Mounting fasteners



**Warning!** All fasteners used to mount the Exterior 200 LED must be corrosion-resistant and strong enough to mount the fixture safely. The washers supplied with the fixture must be installed directly under the fasteners' heads when anchoring the yoke base to the installation surface.

The mounting yoke base must be safely anchored to a horizontal surface. The number and type of fasteners used will depend on the installation, but use at least three high-strength corrosion-resistant fasteners (recommended minimum properties: stainless steel A4-70 grade according to ISO 3506 or steel grade 8.8 according to ISO 898-1). All nuts used must be self-locking. Washers must be installed between the head of each fastener and the yoke base.

The yoke allows the fixture to be manually panned (i.e. rotated horizontally) and tilted for beam aiming adjustment.

See Figure 1. To mount the fixture, use a 12 mm (1/2 inch) thread diameter bolt in the center hole **A**. Then either use two bolts with 12 mm (1/2 inch) shaft diameter passing through holes **B** or use two bolts with 8



mm (5/16 inch) shaft diameter passing through slots **C** to anchor the fixture. installing bolts through slots **C** will give approximately 90° of pan adjustment.

Install washers under all nuts and bolt heads.

If additional bolts are required to mount the fixture safely, install bolts through holes **B** and slots **C**.

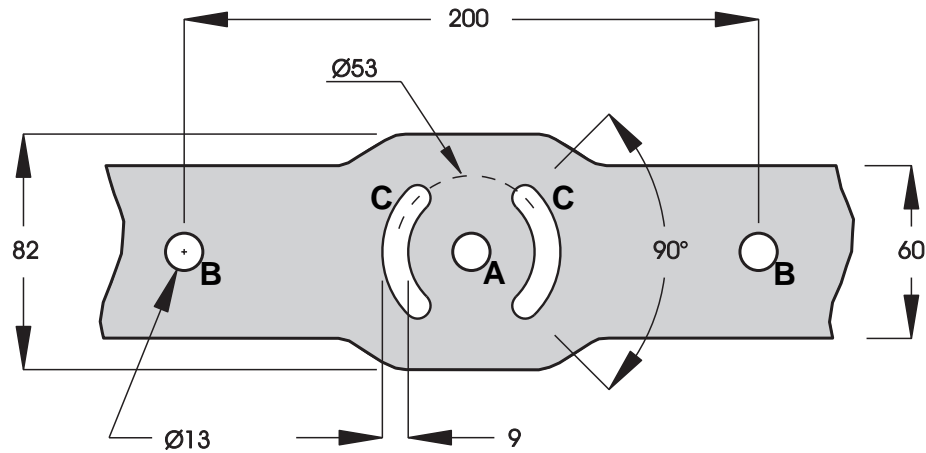
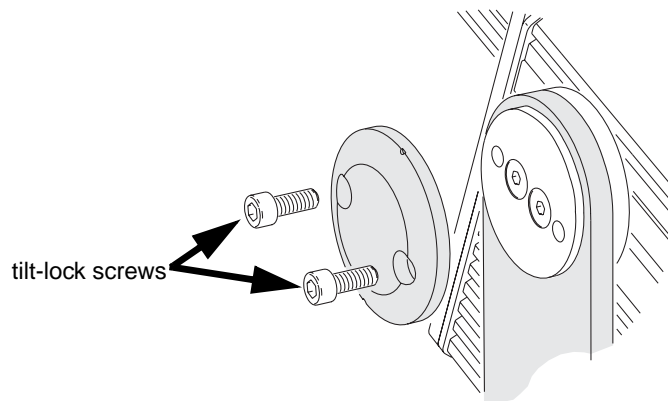

**Figure 1: Mounting yoke attachment points**

## Tilt adjustment

To adjust the tilt:

1. Put on heat-resistant gloves if the fixture has been in use.
2. Loosen, but do not remove, the tilt-lock screws. Tilt the fixture to the desired angle and retighten the screws.



**Figure 2: Tilt adjustment**

# Power and DMX data cable layout

Figure 3 gives an overview of a suitable cable layout. The dotted lines represent AC power circuits. The solid lines represent the data link.

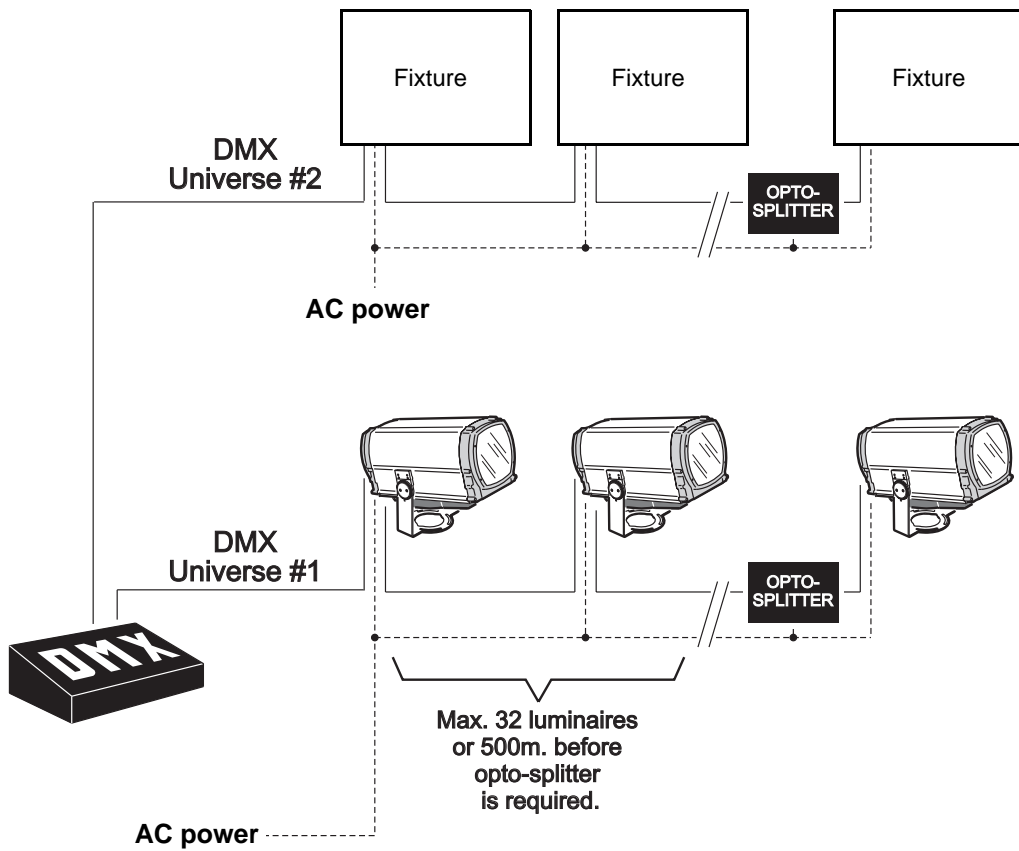

Figure 3: Schematic cable layout diagram

# AC power



**DANGER!** Read “Safety Information” on page 3 before attempting to install this product. Lock out power to the entire installation before working on cables and connections or removing any cover.

**Electrical installation must be carried out by qualified professionals only.**



**For protection from dangerous electric shock, the fixture must be grounded (earthed). The AC power distribution system must be fitted with current overload and ground-fault (earth-fault) circuit breakers as well as a means to isolate fixtures from power and lock out power during service.**



**Important! Do not connect the Exterior 200 LED to an electrical dimmer system. Doing so can damage the electronics.**

See Figure 3 on page 10 for a schematic diagram of cable layout. If you require help in planning or dimensioning the power distribution system, please contact your Martin Architectural supplier for assistance.

If there is a break or cut at any point in a cable (for example at a connection point), and if this is exposed to water, moisture can be drawn up the inside of the cable due to the vacuum effect of temperature fluctuations during operation. Ensure that the fixture is protected from the entry of water via the power cable by using IP65-rated connectors or junction boxes, or by protecting connectors with weatherproof housings.

The Exterior 200 LED is supplied in EU and US models. The only difference between the two models is that the power cable is EU color-coded in EU models and US color-coded in US models (see Table 1). Both models accept AC power at 100 - 240 V nominal, 50 or 60 Hz. Do not connect to power at any other voltage or frequency.

The Exterior 200 LED is protected by a 2.5 amp slow-blow primary fuse located on the power PCB inside the rear cover. See “Fuse replacement” on page 27 for details of changing fuses. See “Specifications” on page 33 for details of fuse rating and typical current.

There is no power on/off switch. Power is applied to the Exterior 200 LED as soon as it is connected to power.

## Connecting to power

The fixture is supplied with a power cable installed ready for connection to a single-phase 3-wire (live, neutral, ground/earth) power distribution system at 100 - 240 V nominal, 50/60 Hz.

**Important!** *If you have any other type of distribution system than the one listed above, you must replace the power cable and connect the fixture to power as described under “Replacing the power cable” on page 12.*

To connect to a single-phase 3-wire (live, neutral, ground/earth) power system:

1. Lock out power to the installation.
2. The power cable color coding for US and EU models is given in Table 1. Connect the conductors in the power cable to the distribution circuit as follows:
  - Connect the green wire (US models) or yellow/green wire (EU models) to ground (earth)
  - Connect the white wire (US models) or blue wire (EU models) to neutral
  - Connect the black wire (US models) or brown wire (EU models) to live.

Wire color (US models)	Wire color (EU models)	Conductor	Symbol	Screw (US)
black	brown	live	L	yellow or brass
white	blue	neutral	N	silver
green	yellow/green	ground (earth)		green

**Table 1: Conductor identification**

3. Check that all installation work is completed and carry out appropriate tests and safety checks before applying power.

## Replacing the power cable

If you replace the supplied power cable, the new cable must be listed, adequately dimensioned for the current requirements and suitable for the installation environment, particularly with regard to water, pollution, thermal and UV resistance. Use Hypalon or neoprene rubber-jacket cable rated to 90° C (194° F) minimum. The conductor size must be 1.5 mm<sup>2</sup> or 16 AWG minimum.

To install a new power cable:

1. Lock out power to the installation and allow the fixture to cool for at least 20 minutes.
2. Loosen the dome nut in the power cable gland and then unscrew the gland from the rear cover.
3. See Figure 4. Remove the rear cover retaining screws (arrowed) and remove the rear cover.
4. Disconnect the existing cable from the power terminals, then remove it together with the old cable gland.
5. Pass the new cable through a new cable gland and through the rear cover.

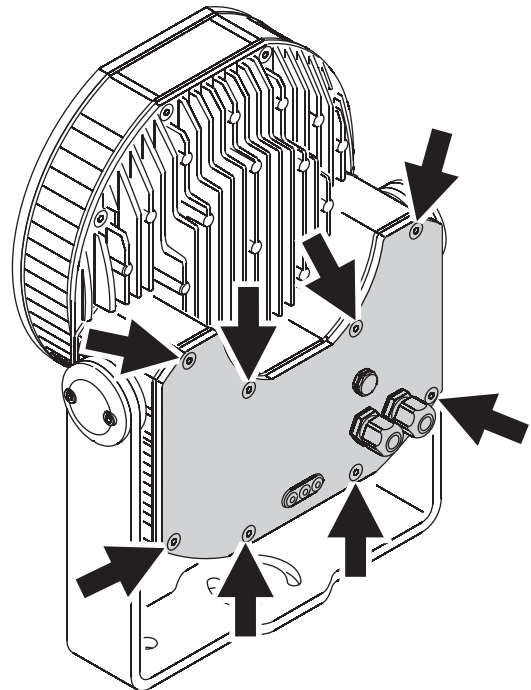

Figure 4: Rear cover retaining screws

6. See Figure 5. Connect the conductors in the new cable to the spring-loaded power terminals in the rear cover as follows:
  - Connect the ground (earth) wire to the terminal marked  $\perp$
  - If using a **single-phase system**, connect the power cable's neutral wire to terminal **N** and connect the power cable's live wire to terminal **L**. **Important! Do not connect the live wire to terminal L2 as there is electrical continuity between this terminal and terminal N (see Figure 6).**

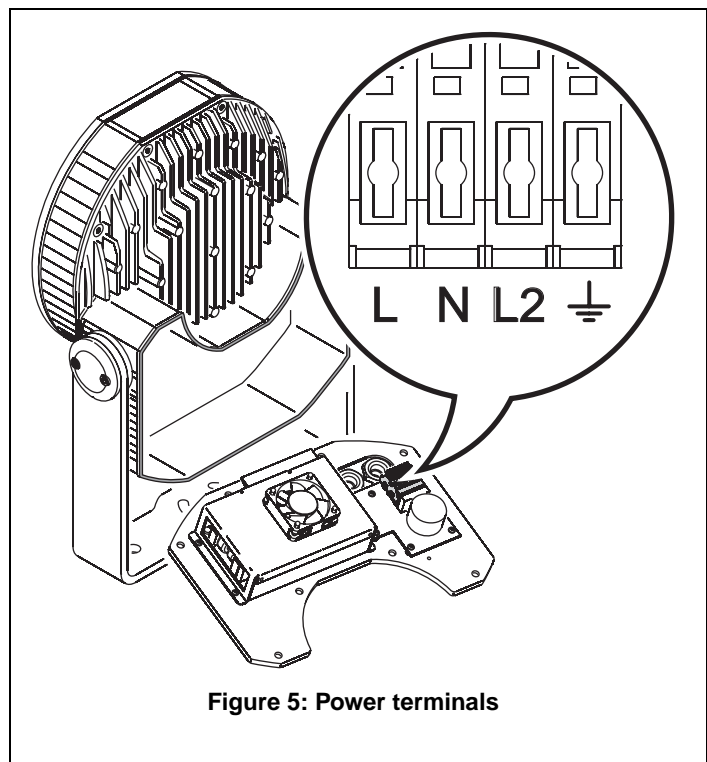
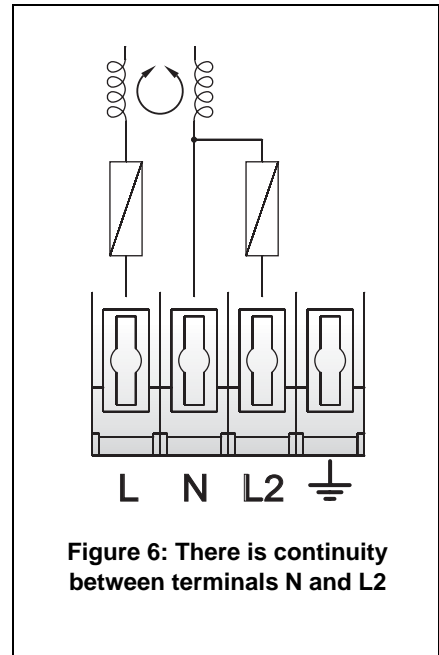

Figure 5: Power terminals

- If using **two phases of a three-phase system** to obtain 200 - 240 V between two phases, connect one phase to terminal **L** and the other phase to terminal **L2**. Do not connect anything to terminal **N**.
  - If using a **single-phase three-wire earthed mid-point system** (used in certain regions of the USA) to obtain 200 - 240 V between two live conductors, connect one live wire to terminal **L** and the other live wire to terminal **L2**. Do not connect anything to terminal **N**.
7. Check that the rear cover seal is in perfect condition, then reinstall the seal and rear cover, cross-tightening the cover retaining screws gradually to 5 - 6 Nm (3.7 - 4.4 ft.-lbs.).
  8. Install the new cable gland as described under "Cable glands" below.

## Power plug

You may need to fit the supplied power cable with a plug that is suitable for your AC power outlets. If so, install a grounding-type (earthed) plug that is rated 5 A minimum, following the plug manufacturer's instructions. Table 1 on page 11 shows some possible pin identification schemes; if pins are not clearly identified, or if you have any doubts about proper installation, consult a qualified electrician. Ensure that all connections are sufficiently protected from water.



**Figure 6: There is continuity between terminals N and L2**

## Cable glands

The IPON<sup>®</sup> IP68-rated cable glands used for power and data cable entry accept cable with 5 - 10 mm (0.2 - 0.4 inch) external diameter. If you replace a cable, install a new rubber seal or complete cable gland if the seal is not in perfect condition. If you use a cable with an external diameter that is not within the range accepted, replace the cable gland with a suitably dimensioned item. Cable glands must be rated IP68 and suitable for the cable diameter and application. New cable glands can be obtained from Martin (P/N 13102000) or from electrical suppliers.

To replace an IPON cable gland:

1. Lock out power to the installation and allow it to cool for 20 minutes.
2. Loosen the dome nut in the existing gland to release the cable, then unscrew the gland from the rear cover.
3. Remove the rear cover from the fixture, note connections and disconnect the cable from its terminals.
4. Slide the old gland off the cable.
5. Screw the new gland into the rear cover until it is tight enough to make a seal. Do not overtighten.
6. Pass the cable through the new gland and rear cover, connect it to its terminals (with reference to "Replacing the power cable" on page 12 or "Connection pinouts" on page 14 if necessary), then reinstall the rear cover.
7. Tighten the dome nut on the cable gland before applying power.

# Control data link

Exterior 200 LED fixtures must be connected via a control data link for DMX controller or synchronized (master/slave) operation. The following considerations must be taken into account when planning the data link:

- RS-485 data cable designed for exterior use is required for outdoor installations. RS-485 cable has low capacitance and a characteristic impedance of 85 to 150 Ohms. It is electrically shielded and has at least 1 twisted pair of conductors. The minimum recommended wire size is 0.25 mm<sup>2</sup> (24 AWG) for runs up to 300 meters (1000 ft.) and 0.32 mm<sup>2</sup> (22 AWG) for runs up 500 meters (1640 ft). CAT 5 network cable designed for direct burial can be used in outdoor installations, but you are recommended to run it inside conduit.
- The maximum permitted control data cable length before a control signal amplifier is required is 500 meters (1640 ft.).
- Fixtures must be 'daisy-chained', i.e. the data cable must be connected in one single chain of fixtures as shown in Figure 7.
- Each chain may connect a maximum of 32 fixtures.
- An optically isolated amplifier-splitter such as the Martin RS-485 Opto-Splitter (P/N 90758060) must be used to:
  - extend a link beyond 500 meters (1640 ft.)
  - extend the link to include a further maximum 32 fixtures, or
  - branch the link into further single chains, each containing 32 fixtures. The Martin Opto-Splitter allows a link to be branched into four new chains.
- Each chain on the link must be terminated by placing a 120 ohm resistor (available from Martin, P/N 04150308) across the data hot (+) and cold (-) conductors of the last fixture on the chain.
- Long parallel runs of AC power and control data cables may cause interference on the data link and must be avoided. Even if not required by law, use separate conduits for power and data cables.
- One DMX universe has 512 DMX control channels available. If individual control of the fixtures in an installation is required, each fixture must be given its own channels until the limit of 512 is reached. At this point, a new DMX universe must be created before more fixtures can be added.
- The number of fixtures that can be individually controlled in one DMX universe depends on the number of DMX channels they use. If Exterior 200 LED fixtures are set to HSI mode, each fixture require 3 DMX channels (one channel for hue, one for saturation and one for intensity). The total number of Exterior 200 LED fixtures that can be linked in one DMX universe will therefore be  $512/3 = 170$ .

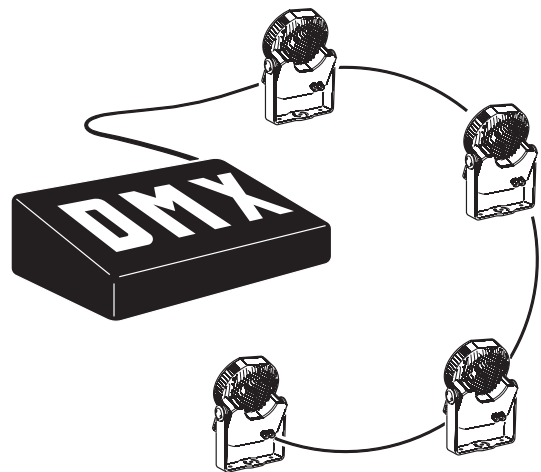

Figure 7: DMX link

## Connection pinouts

### ***XLR connection***

XLR connectors are suitable if DMX cable is used for the data link. XLR pin numbers are normally marked on connectors. Connectors must be wired using the standard XLR DMX pin-out:

- Pin 1: Cable shield
- Pin 2: DMX Data 1 - (cold)
- Pin 3: DMX Data 1 + (hot)

Pins 4 and 5 on 5-pin XLR connectors are available for Data 2 connections in DMX 512-A or similar systems. They must be wired as follows:

- Pin 4: DMX Data 2 - (cold)
- Pin 5: DMX Data 2 + (hot)

To avoid ground/earth loop interference, ensure that the DMX cable shield does not come into contact with the shell or body of XLR connectors.

### RJ-45 connection

RJ-45 connectors are suitable if CAT 5 cable is used for the data link. RJ-45 cable connector pins are numbered from the left looking at the face of the connector with the locking clip on top (see Figure 8). Connectors must be wired according to the 568-B system using the standard RJ-45 pin-out for DMX applications:

- Pin 1 (White/orange): DMX data hot (+)
- Pin 2 (Orange): DMX data cold (-)
- Pins 7 (White/brown) and 8 (Brown): Common

Pins 3 and 6 are available for Data 2 connections in DMX 512-A or similar systems. They must be wired as follows:

- Pin 3 (White/green): Available for Data 2 hot (+)
- Pin 6 (Green): Available for Data 2 cold (-)

Pins 4 and 5 are not used in currently available lighting control systems but can be wired as follows:

- Pin 4 (Blue)
- Pin 5 (White/blue)

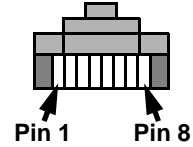

Figure 8: RJ-45 cable connector pins

## Connecting the data link



**DANGER!** Lock out power to the entire installation before working on cables and connections or removing any cover.

**Warning!** Make sure that data connections are totally protected from water, or moisture may be drawn up the inside of the cable due to the vacuum effect from the heat generated during operation.

The Exterior 200 LED is supplied with a 1.8 meter (5.9 ft.) data cable tail for data connection. The cable contains both input and output conductors that are identified as follows:

- 1 x shield = data input and output common
- 2 x white wires = data input and output hot (+)
- 1 x green wire = data input cold (-)
- 1 x brown wire = data output cold (-)

To connect a fixture to the data link:

1. Connect the conductors in the fixture's cable tail to the data cable respecting the above color code. If required, install input and output connectors on the data cable respecting the pinouts described in "Connection pinouts" on page 14. Standard procedure is to use a male connector on a fixture or its cable tail for data input and a female connector for data output. Do not connect the shield conductor to ground (earth) or allow it to come into contact with a connector shell, as this may cause interference.
2. Protect connectors in a weatherproof housing if they are not totally weatherproof.

### Replacing the data cable

If you replace the supplied DMX data cable tail, connect the new cable's conductors to the data terminals as shown in Figure 9 and follow the instructions under "Cable glands" on page 13 to ensure correct weatherproofing.

If the new cable is not the same diameter as the supplied cable, or if the cable gland seal is not in perfect condition, install a new rubber seal or complete cable gland.

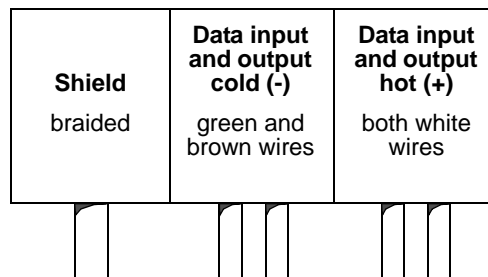

Figure 9: Data terminals

# Fixture setup

## Setting up a fixture with a PC and MUM

The Martin MUM (Multi-Utility Manager) application allows you to program and configure Martin Architectural fixtures from a laptop PC and features an intuitive GUI (graphic user interface).

Using MUM, you can connect to and set up one fixture at a time. Refer to the MUM user manual for instructions on installing and starting the MUM application.

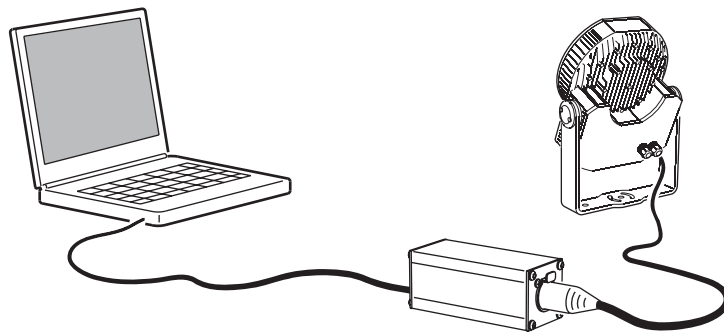

**Figure 10: Connecting to a PC with MUM**

### Connecting a PC with MUM

To connect a PC with MUM to an Exterior 200 LED:

1. Obtain the MUM application, a DABS1 adaptor and interface cables. These are available as a set, P/N 90758090, from Martin Architectural.
2. Connect the DABS1 adaptor to your PC using the USB cable.
3. Connect the DABS1 adaptor to the Exterior 200 LED using an XLR connector connected to the data link. Note that you may only connect to one fixture at a time.
4. Apply power to the Exterior 200 LED and start the MUM application. The application will automatically detect an Exterior 200 LED if it is powered on and correctly connected. It will also retrieve information and current settings from the fixture and display them.



## Configuring a fixture with MUM

### Setting the clock

The Exterior 200 LED has a battery-operated 24-hour clock that is used to start and stop stand-alone operation.

To set the clock:

1. Click on the **Fixture Info** button in MUM.:

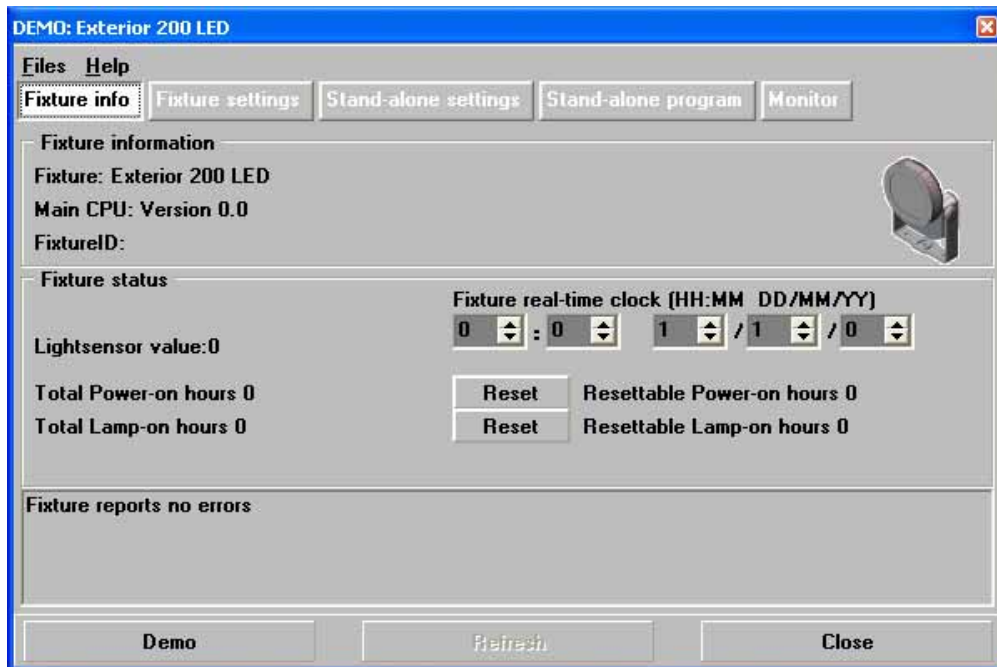

Figure 11: Fixture info window

2. Using the **Fixture real-time clock** spin buttons, set the fixture to the current time (expressed in the 24-hour clock in hours and minutes) and date. The time will be updated in the fixture in real time.

### Setting DMX address and DMX color control mode

If individual control of each Exterior 200 LED is required, each fixture must be set up to receive instructions from the DMX controller on a group of DMX channels that are not used by any other device in its DMX universe. The DMX address, also known as the control address or start channel, is the first of these channels. Each fixture uses this channel and the channels immediately above it to receive instructions.

Exterior 200 LED fixtures use 3, 4 or 5 DMX channels, depending on which DMX color control mode they are set to. If a fixture's DMX address is set to 1 and the fixture is in RGBAW DMX mode, it will use channels 1 - 5. Channel 6 will be available as the DMX address for the next fixture.

If two or more fixtures are set up with the same address, they will receive the same instructions and behave identically. Setting up identical fixtures with the same address is a good tool for troubleshooting unexpected behavior and an easy way to achieve synchronized action.

### **DMX Address**

To set the DMX address using MUM, click on the **Fixture settings** button and use the **DMX Address** spin buttons to set the fixture's DMX address. The DMX address will be updated in the fixture in real time.

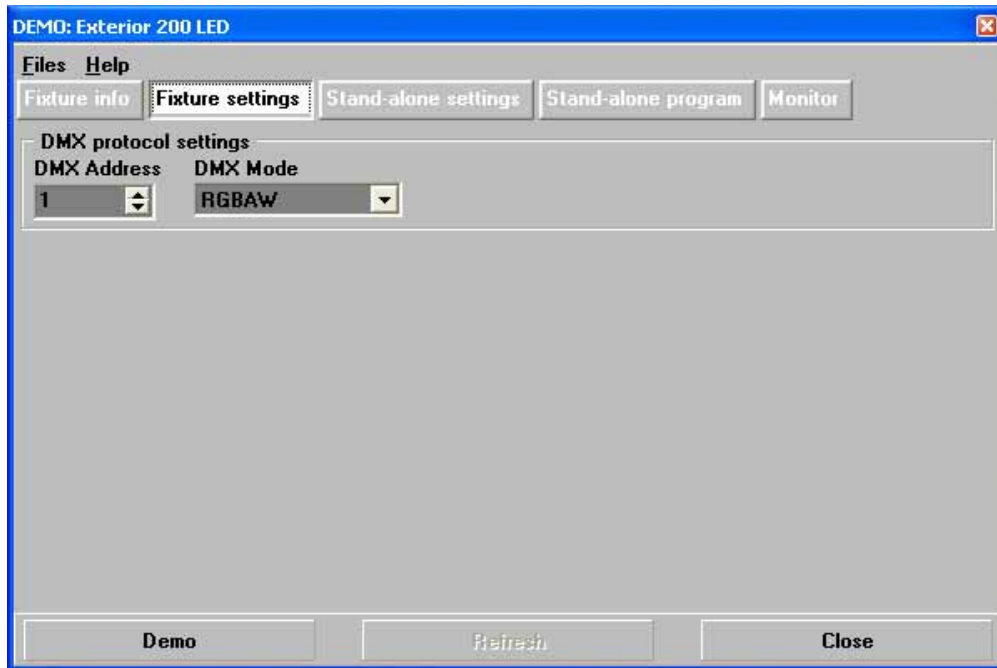

**Figure 12: Fixture settings window**

### **DMX Mode**

The **DMX mode** setting allows you to set the fixture to respond in one of four color control modes:

- **RGBAW** (red, green, blue, amber, white)
- **RGB** (red, green, blue)
- **HSI** (hue, saturation, intensity)
- **HSIC** (hue, saturation, intensity, color temperature)

To set the DMX mode using MUM, click on the **Fixture settings** button and use the **DMX Mode** drop-down dialog box to select the desired mode. The DMX mode will be updated in the fixture in real time.

Remember that changing the DMX mode will affect the number of channels the fixture uses.

# Operation



**Warning! Class 3B LED product. Do not look into the beam at a distance of less than 2.2 meters (7 feet 3 inches) from the front surface of the product. Do not view the light output with optical instruments or any device that may concentrate the beam.**

The Exterior 200 LED can be operated using a DMX controller or programmed to run a stand-alone light show without DMX control.

## Ambient temperatures

The Exterior 200 LED can be operated at ambient temperatures from -30° C (-22° F) to 45° C (113° F).

At temperatures below 0° C (32° F), leave the fixture permanently powered on, even if LEDs are dimmed to zero because light output is not required. The standby power will provide a little heat and help protect circuits and components from the effects of low temperature.

## DMX control

In DMX-controlled operation, faders on the DMX controller are used to control color and intensity. The control method depends on which DMX mode the fixture is set to (see “DMX Mode” on page 18).

In **RGB** mode, three channels on the controller are used to control the intensity of red, green and blue color from 0% to 100%.

In **RGBAW** mode, five channels on the controller are used to control the intensity of red, green, blue, amber and white color from 0% to 100%.

In **HSI** mode, three channels on the controller are used to control hue, saturation and intensity. Hue is controlled in the following order: Red → Orange → Amber → Yellow → Green → Cyan → Blue → Indigo → Violet → Magenta → Red. Saturation and Intensity can be varied from 0% to 100%.

In **HSIC** mode, four channels are used to control hue, saturation, intensity and color temperature. Hue, saturation and intensity are controlled as in HSI mode, and color temperature can be varied from 2000 to 1000 K.

## Stand-alone operation

In stand-alone operation, the fixture executes color changes at set intervals and speeds, at pre-defined periods during the day, and/or when the light level falls below a defined level. The term *stand-alone* means that the Exterior 200 LED is not connected to a control device, but is pre-programmed with a sequence of up to 20 scenes that play continuously in a loop.

## Configuring stand-alone settings

First, the fixture needs to be configured to know if and when to activate a stand-alone program. Connect a PC running the MUM application as described in "Connecting a PC with MUM" on page 16, and click on the **Stand-alone settings** button (see Figure 13).

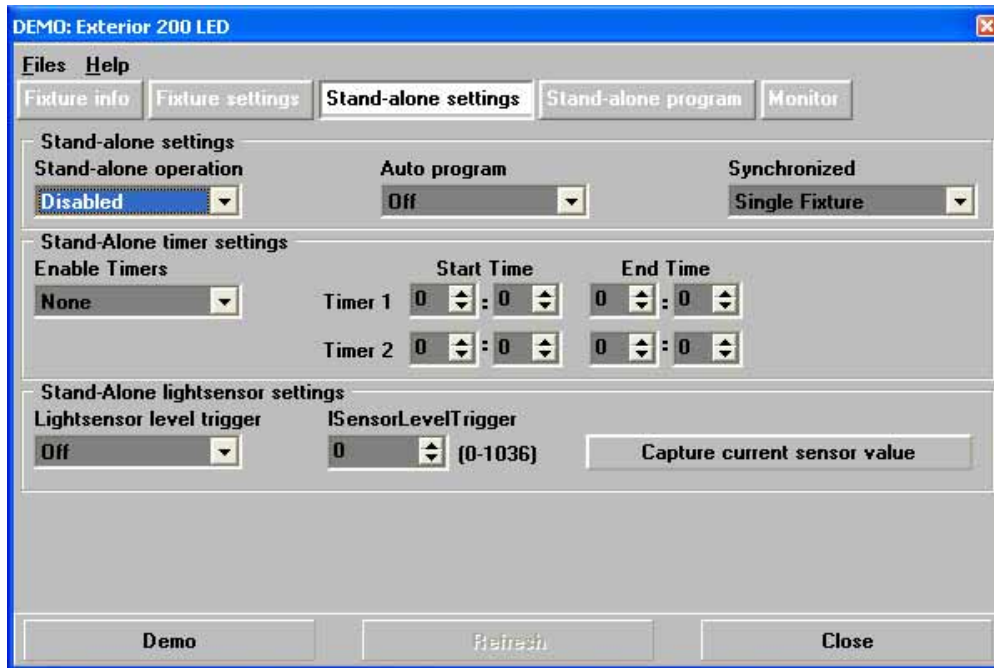

Figure 13: Stand-alone settings window

Stand-alone operation can be set to:

- start automatically as soon as power is applied
- respond to a timer trigger that activates operation for one or two periods in a 24 hour period, or
- respond to a light-level trigger that uses a light sensor to activate operation when ambient light is below a certain level.

If both the timer *and* the light-level trigger are used, operation starts whenever it is darker than the light-level setting, and within the times set.

### **Enabling stand-alone operation**

To enable stand-alone operation, set **Stand-alone operation** to **Enabled**.

### **Starting automatically**

To set stand-alone operation to start automatically, set **Auto program** to **On**. The fixture will now start stand-alone operation automatically as soon as power is applied and no DMX signal is being received.

### **Setting a timer trigger**

To set a timer trigger:

1. Make sure the correct time has been set on the luminaire's built-in clock (see "Setting the clock" on page 17).
2. Select **None**, **Timer 1**, **Timer 2** or **Both Timers** in the **Enable Timers** box.
3. Use the **Start Time** and **End Time** spin buttons to set a period of stand-alone operation on the selected timer(s).

### **Setting a light-level trigger**

To set a light-level trigger:

1. Set **Light level sensor trigger** to **On**.
2. Set the light level that triggers stand-alone operation using the **Trigger level** spin button, or press **Capture current sensor value** to set the current ambient light level to trigger stand-alone operation.

To avoid false triggering by sudden light changes (caused by vehicle headlights or clouds, for example), the light level must remain above or below the trigger threshold for 5 minutes to activate the trigger.

## Programming stand-alone operation

### About scenes

A stand-alone light show consists of scenes. Each scene is a particular lighting effect with predetermined color, intensity and duration. Up to 20 scenes can be programmed into the Exterior 200 LED's program memory.

Each scene has a dynamic part – the fade – during which effects move to the scene's programmed positions, and a static part – the wait – where effects do not change.

The duration of the fade and wait is programmed individually for each scene. The fade time may be 0 - 120 seconds; the wait time may be 1 second to 12 hours. The total time it takes a scene to execute is the sum of the fade and wait times.

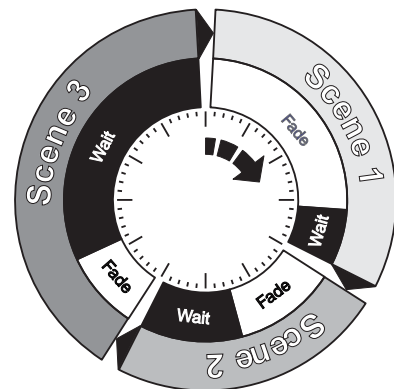

Figure 14: Scene timing

### Programming scenes

To program a scene:

1. click on the **Stand-alone program** button (see Figure 15).
2. Depending on which DMX mode the fixture is set to, the stand-alone programming window will show columns for RGB, RGBAW, HSI or HSIC. Apply values by setting levels in each column.
3. Select a fade time and a wait time for the scene.

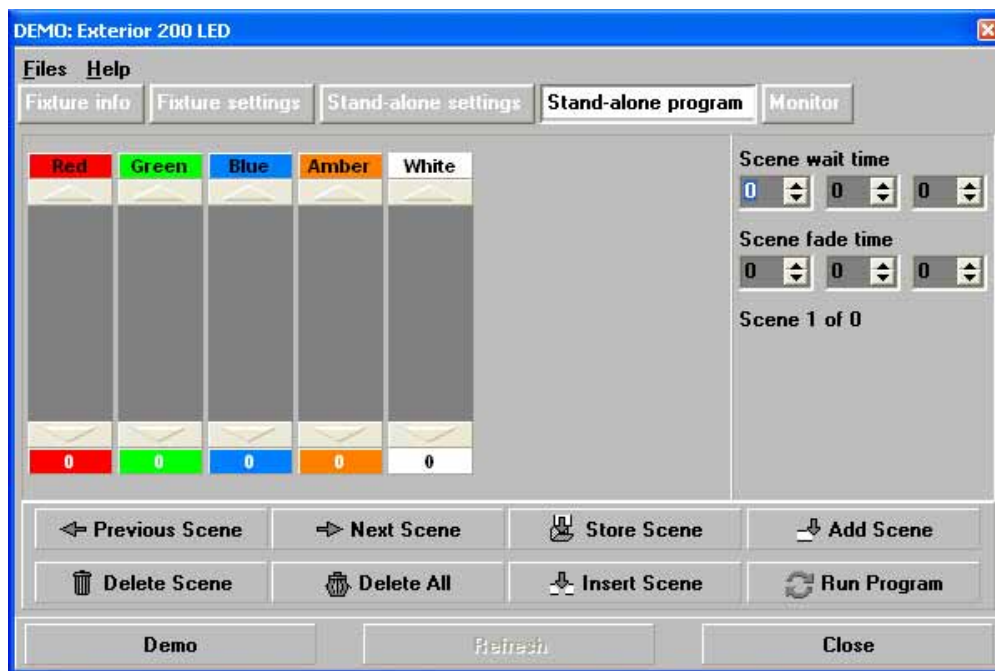

Figure 15: Stand-alone programming window

### Scene management

Once you have specified values for the effects and fade and wait times for the scene, you can store and manage scenes using the commands available at the bottom of the **Stand-alone program** window:

<b>Store scene</b>	Save settings in the current scene.
<b>Add scene</b>	Save settings in a new scene at the end of the current sequence of scenes.
<b>Insert scene</b>	Save settings in a new scene before the current scene. <i>Tip: Think of the Add and Insert commands as Save commands, to be used as the last step after programming all effects.</i>
<b>Delete scene</b>	Remove the current scene from memory. Scenes after the deleted scene are renumbered.
<b>Next scene</b>	Step to the next scene.

<b>Previous scene</b>	Step to the previous scene.
<b>Delete all</b>	Remove all scenes from the luminaire memory.
<b>Run program</b>	Run the scenes in the programmed light show.

When the program is run by applying the **Run program** command, scenes execute in a continuous, ascending loop.

## Synchronizing stand-alone operation

If you are running multiple fixtures on a data link, you can synchronize action so that all fixtures start their programmed shows and start fading to the next scene at the same time.

### **Setting master and slave fixtures**

In synchronized operation, one fixture is set as the master and the others are set as slaves. Each fixture must be programmed with its own show. When the master fades to the next scene or starts its show from the beginning again, it tells each slave fixture to fade to its next scene or start its show again. In other words, each slave fixture will run its show repeatedly in a cycle, changing scene when prompted to by the master, until the master finishes its own show and signals that all fixtures should start from the first scene once again.

Before running synchronized operation, you must set fixtures to one of the following in the **Synchronized** drop-down dialog box (see Figure 13):

- **Single Fixture:** operates in stand-alone mode independently of other luminaires
- **Master:** sends trigger signals to other luminaires, or
- **Synchronized:** slave – receives trigger signals from other luminaires.

*No more than one luminaire may be the master.* Any luminaire on the link, regardless of its position, may be the master. All other luminaires must be set as slaves.

### **Combining with other fixtures**

An Exterior 200 LED running a stand-alone show can perform synchronized scene changes with other Exterior 200 LED fixtures as well as Martin Architectural fixtures of the following types:

- Exterior 1200 Wash
- Exterior 1200 Image Projector
- Exterior 200
- Exterior 600
- Exterior 600 Compact
- Inground 200 CMY
- Inground 200 6-Color
- FiberSource CMY150
- Imager series
- Alien O2 series
- MiniMAC Maestro
- smartMAC

### **Stand-alone programming tips**

If you want to keep things as simple as possible when programming synchronized operation, ensure that:

1. Every fixture has the same number of scenes.
2. Scene times are a few seconds longer on the master fixture than on slave fixtures (this will ensure that slave fixtures always have time to finish scenes before the master tells them to start the next scene).

It is important to note that the only commands transmitted by the master are scene change and show start commands. No data about the *appearance* of the scene is transmitted between fixtures.

If you are programming a group of fixtures to perform the same scenes with synchronized master/slave triggering, we recommend that you:

1. Use MUM to program a show on one slave fixture
2. Download and save this fixture's program and settings to your PC using MUM's Files menu (see Figure 16), and then
3. Upload the program and settings to each subsequent fixture that you connect to.

For a more detailed explanation of synchronized operation and how advanced effects can be created by programming fixtures with a different number of scenes, see the next section.

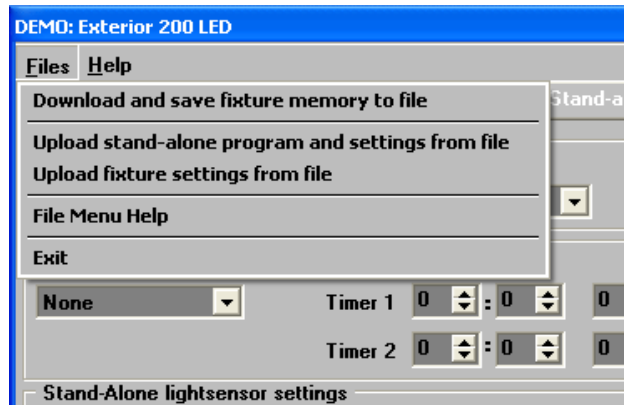

Figure 16: Managing fixture settings and stand-alone programs as files

## Synchronized stand-alone operation: detailed description

**Note:** *This section gives advanced information about stand-alone synchronized operation. You only need to read it if you require help with problem diagnosis or if you want to program advanced synchronized light shows.*

The principles in stand-alone synchronized operation are as follows:

1. A scene contains a fade section, followed by a wait section
2. Each fixture can be individually programmed with up to 20 scenes, and each scene can have its own individual fade and wait times.
3. Scenes are numbered from 0 to 19.
4. In synchronized operation, one master fixture issues commands to the other slave fixtures to “go to scene xx”, where xx is the scene number that the master will execute next.
5. If a slave has fewer scenes than the master, it will derive which scene to go to by dividing the number of the scene it has been commanded to go to (scene 5, for example) by the total number of scenes that the slave fixture has (4, for example) in whole numbers (no decimal places). In this example 5 divided by 4 results in 1, with 1 remainder. This remainder will be the number of the scene that the slave fixture starts - scene 1. Generally though, when a Slave fixture reaches its own last scene before the Master fixture, a “go to scene xx” message will result in the first scene being played.
6. If a slave has more scenes than the master calls, the last scenes in the slave will never be executed, as is the case with scene S4 in the following example.

F=fade, W=wait	Timeline =>				
	M0	M1	M2	M3	
Programmed in Master	F   W	F   W	F   W	F   W	
	S0	S1	S2	S3	S4
Programmed in Slave	F   W	F   W	F   W	F   W	F   W
Result	M0	M1	M2	M3	
	F   W	F   W	F   W	F   W	
	S0	S1	S2	S3	
	F   W	F   W	F   W	-- --	F   W

7. In synchronized operation, the wait time is determined by the master. Every slave fixture fades and waits at its own rate and then remains in the “wait” state until it receives a “start scene xx” command from the master.
8. A slave fixture will not listen for the next message from the master fixture before it has finished its current scene. This may result in a slave skipping a scene if the slave has a longer scene time than the master.

Note that in the following example, the scenes in the slave run out of their programmed sequence because scenes 0 and 2 on the slave are longer than the corresponding scenes on the master.

M=master, S=slave

F=fade, W=wait **Time >**

	M0	M1	M2						
<b>Programmed</b>									
Master	F	W	F	W	F	W			
Slave	F	W	F	W	F	W			
<b>Result</b>									
Master	F	W	F	W	F	W	F	W	F
Slave	F	W			F	W	..	..	F



# Service and maintenance



**DANGER!** Read “Safety Information” on page 3 before carrying out service or maintenance work on the Exterior 200 LED. Lock out power to the entire distribution system before servicing or opening any cover.

**Important!** The Exterior 200 LED requires regular service and maintenance to maintain reliable operation and protect the investment it represents. Excessive dirt and particle buildup degrades performance, causes overheating and will damage the fixture. Damage caused by inadequate cleaning or maintenance is not covered by the product warranty.

**Important!** As with electronic components in general, the Exterior 200 LED’s PCBs are sensitive to ESD (electrostatic discharge). Take precautions to avoid ESD damage during service.

The service and maintenance procedures described in this section must be carried out by qualified professionals only. Any service procedures not described in this section must be carried out by the Martin Service organization or its authorized agents.

It is Martin policy to use the best quality materials available to ensure optimum performance and the longest possible component lifetimes. However, optical components in all lighting fixtures are subject to wear and tear over the life of the fixture, resulting in gradual changes in color rendition, for example. The extent of wear and tear depends heavily on operating conditions, maintenance and environment, so it is impossible to specify precise lifetimes for optical components. However, you will eventually need to replace LEDs if their characteristics are affected by wear and tear after an extended period of use and if you require fixtures to perform within very precise optical and color parameters.

When installing front and rear covers, use a torque driver and cross-tighten screws (tighten screws opposite each other gradually in steps, working around the cover) to 5 - 6 Nm (3.7 - 4.4 ft.-lbs.).

## Cleaning

Regular cleaning is essential for fixture life and performance. Buildup of dust and dirt degrades the fixture’s light output and cooling ability.

Cleaning schedules will vary greatly depending on the operating environment. It is therefore impossible to specify precise cleaning intervals for the Exterior 200 LED. Inspect fixtures within their first few weeks of operation to see whether cleaning is necessary. Check again at frequent intervals. This procedure will allow you to assess cleaning requirements in your particular situation. If in doubt, consult your Martin dealer about a suitable maintenance schedule.

Do not use products that contain solvents, abrasives or caustic agents for cleaning, as they can cause surface damage to the fixture.



**Warning!** Do not use a high-pressure water jet for cleaning. Take care not to damage seals and wiring during cleaning.

The Exterior 200 LED’s aluminum housing and front glass can be cleaned with mild detergents such as those for washing cars. To clean the housing and front glass:

1. Isolate the fixture from AC power and allow the fixture to cool for 20 minutes.
2. Visually check that the silicone seals are in good condition. If any seal shows signs of damage or loss of water resistance, stop cleaning the fixture and contact a Martin authorized service technician for seal replacement.
3. If seals are in good condition, rinse off loose dirt with a hosepipe or low-pressure water spray. Do not spray water into the heat exchanger.
4. Wash the aluminum housing and front glass using warm water with a little mild detergent and a soft brush or sponge. Do not use abrasive cleaners.
5. Rinse with clean water and wipe dry.

# Installing and removing a diffuser filter

**Important!** *Install diffuser filter sheets with the matt, textured surface against the front glass and shiny, untextured surface facing in towards the LEDs.*

The Exterior 200 LED is supplied with a narrow diffuser filter installed and medium and wide diffuser filters packed separately with each product. Diffuser filters soften the output from the LEDs and alter the beam angle. See Figure 18: diffuser filters are marked with notches to identify them.

To install a diffuser filter:

1. Isolate the fixture from power. If the fixture has been in use, allow it to cool for at least 20 minutes.
2. See Figure 17. Remove the front cover screws and front cover with its seal.
3. Loosen the diffuser retaining clips and remove the currently installed diffuser filter.
4. Slide in the new filter so that its matt, textured side faces forwards towards the glass and its edges locate under the clips. Tighten the clips so that the filter is pressed against the front glass.
5. Replace the front cover as follows:
  - a. Check that the seal is in perfect condition.
  - b. Drive all screws to the bottom without tightening (finger tight).
  - c. Cross-tighten all screws gradually to a maximum torque of 5 - 6 Nm (3.7 - 4.4 ft.-lbs.). Do not over-tighten, or the front glass may break.
6. Reapply power.

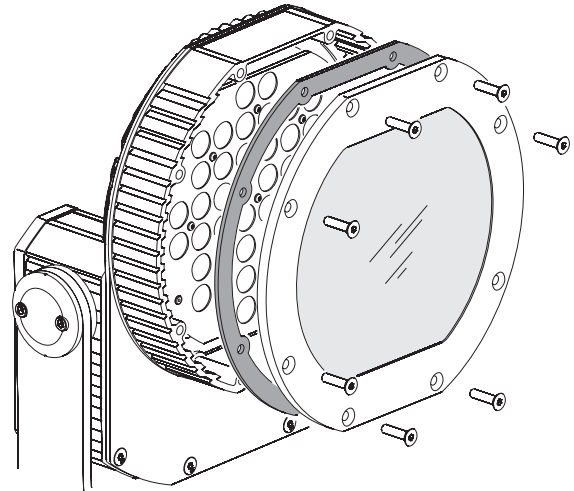

Figure 17: Front cover screws and seal

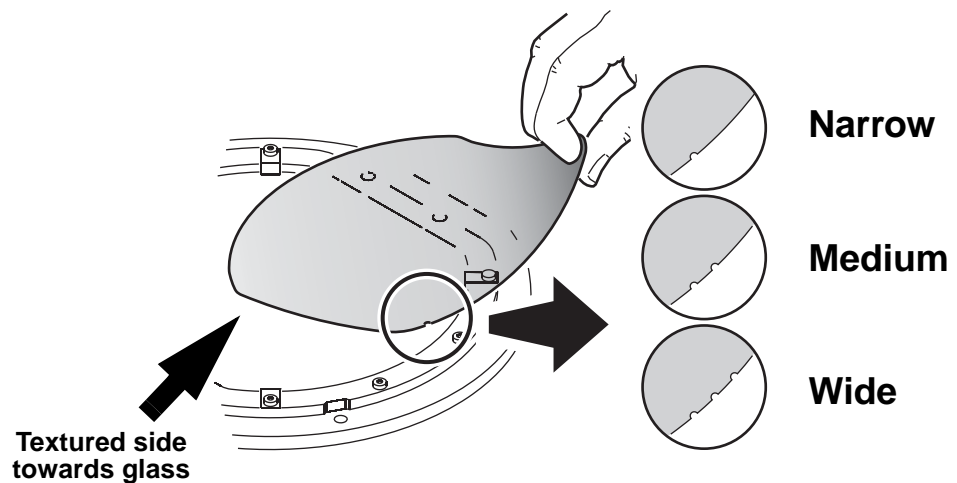

Figure 18: Installing a diffuser filter

## Fuse replacement



**DANGER!** Lock out power to the entire distribution system before servicing or opening any cover. Replace fuses with ones of the same type and rating only.

### Primary fuse



Exterior 200 LED fixtures are protected by a 2.5 amp slow-blow primary fuse located on the power PCB. If a fixture is completely dead, the primary fuse may have blown.

To replace the primary fuse:

1. Isolate the fixture from power and allow to cool for 20 minutes.
2. Open the rear cover.
3. Replace a defective fuse with one of the same type and rating only. Replacement primary fuses are available from Martin suppliers (P/N 05020013).
4. Check that the seal is in perfect condition, then reinstall the rear cover, gradually cross-tightening the eight M6 screws working diagonally. Tighten to a maximum torque of 5 - 6 Nm (3.7 - 4.4 ft.-lbs.).
5. Reapply power.

## Fixture readouts in MUM

Various types of data can be displayed by connecting a PC as described in "Connecting a PC with MUM" on page 16 and clicking on the **Monitor** button:

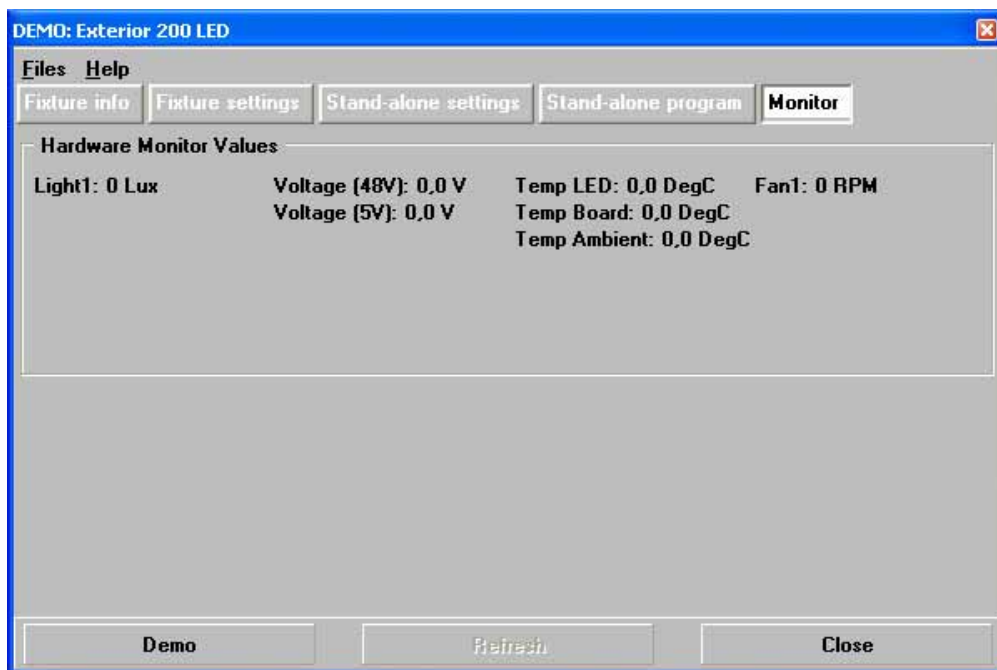

**Light1** displays the light level currently measured by light sensor 1 on the back of the fixture.

**Voltage** displays the current voltage in 48 V and 5 V circuits on the main PCB (this data is for service purposes).

**Temp** displays the current temperature on the LED circuit board that gives the highest reading, the current main PCB temperature and the current ambient temperature.

**Fan1** displays the current cooling fan speed in RPM (revolutions per minute).

## Software installation

It may be necessary to upload new software (i.e. firmware) to the Exterior 200 LED if you believe that the product has a software-related fault or if you want to update to a newer version. Software updates are

available from the Martin website (<http://www.martin.com>) and can be installed via the DMX data link with the following items:

- The Martin Uploader application, version 5.0 or later, downloadable free of charge from the Support area of the Martin website.
- The Exterior 200 LED main CPU software update file, downloadable free of charge from the Support area of the Martin website (this file can be downloaded automatically from within the Martin Uploader application)
- A Martin Universal USB-DMX Interface or similar PC/fixture hardware interface and a Windows PC (if you have a Martin MP-2 Uploader device, it can also be used).

## Installing software: normal method

1. Connect the uploader hardware to a Exterior 200 LED fixture's data input connector. The software will be uploaded to that fixture and all Exterior 200 LED fixtures that are powered on and connected via the DMX link.
2. Upload the fixture software as described in the uploader's help file or user documentation.
3. Disconnect the uploader hardware and reconnect the fixture to the DMX link.
4. Cycle power off and on. Check that the fixture resets correctly. If an error message appears in the display, cycle power off and on again and check that the fixture now resets correctly.

## Installing software: boot mode upload

A boot mode upload may be required if the software update notes call for it or if the fixture software is seriously corrupted and the fixture will not accept a software upload using the normal method described above.

To carry out a boot mode upload:

1. Isolate the fixture from power and allow to cool for at least 20 minutes.
2. Open the rear cover as described for access to the main PCB.
3. Locate the DIP switch on the main PCB and move pin 6 to OFF.
4. Reinstall the rear cover seal and the rear cover temporarily.
5. Reapply power and perform the upload as described above.
6. Isolate from power, open the rear cover and return DIP move pin 6 back to ON.
7. Check that the rear cover seal is in perfect condition, then reinstall the seal and the rear cover, cross-tightening screws gradually to 5 - 6 Nm (3.7 - 4.4 ft.-lbs.) and reapply power.
8. Check that the fixture resets correctly. If an error occurs, cycle power off and on again and check that the fixture now resets correctly.

Normal DIP switch setting

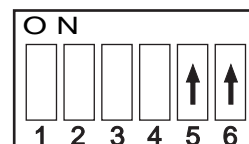

DIP switch setting for boot mode upload

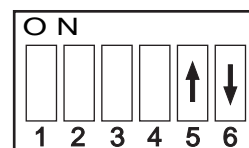

*Details corrected in manual Rev. D*

## Status indicators

Two LEDs on the rear cover give information about fixture status.

### LED 1 (Fixture status)

- Flashes red if an error occurs that requires service intervention.
- Lights steady green when the fixture is ready for operation.
- Lights steady yellow during a software upload.
- Flashes yellow while the fixture is resetting.

	LED 1 (Fixture)		LED 2 (DMX)	
	On	Flash	On	Flash
Red	—	Error	Illegal data	—
Green	Ready	—	DMX ok	Data ok
Yellow	Upload	Reset	Upload	Reset

*No light in LED1 = No power No light in LED2 = No DMX*

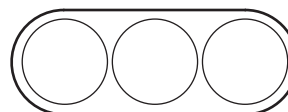

LED 1 LED 2 Sensor

### LED 2 (DMX status)

- Lights steady red if the fixture receives data it cannot recognize.

- Lights steady green when the fixture is successfully receiving a DMX signal.
- Flashes green when the fixture is successfully receiving a data signal.
- Lights steady yellow during a software upload.
- Flashes yellow while the fixture is resetting.

# DMX protocols

## RGB Mode

**Start code = 0**

Channel	Value	Percent	Function
1	0 - 255	0 - 100%	<b>Red</b> Intensity 0 →100%
2	0 - 255	0 - 100%	<b>Green</b> Intensity 0 →100%
3	0 - 255	0 - 100%	<b>Blue</b> Intensity 0 →100%

## RGBAW Mode

**Start code = 0**

Channel	Value	Percent	Function
1	0 - 255	0 - 100%	<b>Red</b> Intensity 0 →100%
2	0 - 255	0 - 100%	<b>Green</b> Intensity 0 →100%
3	0 - 255	0 - 100%	<b>Blue</b> Intensity 0 →100%
4	0 - 255	0 - 100%	<b>Amber</b> Intensity 0 →100%
5	0 - 255	0 - 100%	<b>White</b> Intensity 0 →100%

## HSI Mode

**Start code = 0**

Channel	Value	Percent	Function
1	0 - 255	0 - 100	<b>Hue</b> Red → Orange → Amber → Yellow → Green → Cyan → Blue → Indigo → Violet → Magenta → Red
2	0 - 255	0 - 100	<b>Saturation</b> Zero (white) → Full
3	0 - 255	0 - 100%	<b>Intensity</b> Intensity 0 →100%

In HSI mode, white color temperature is fixed at 5500 K.

# HSIC Mode

**Start code = 0**

<b>Channel</b>	<b>Value</b>	<b>Percent</b>	<b>Function</b>
<b>1</b>	0 - 255	0 - 100	<b>Hue</b> Red → Orange → Amber → Yellow → Green → Cyan → Blue → Indigo → Violet → Magenta → Red
<b>2</b>	0 - 255	0 - 100	<b>Saturation</b> Zero (white) → Full saturation
<b>3</b>	0 - 255	0 - 100%	<b>Intensity</b> Intensity 0 → 100%
<b>4</b>	0 - 255	0 - 100	<b>Color Temperature Control</b> 2000 - 10 000 K

A DMX value of 191 (75%) must be sent on channel 4 to obtain a white color temperature of 5500 K.

# Troubleshooting

Problem	Probable cause(s)	Remedy
Fixture is completely dead.	No power to fixture.	Check power and connections.
	Primary fuse blown (located in fuseholder on rear panel).	Isolate fixture from power. Check fuse and replace.
One or more fixtures responds incorrectly to control or does not respond at all.	Fault on DMX link.	Inspect connections and cables. Correct poor connections. Repair or replace damaged cables.
	Incorrect fixture addressing.	Check fixture is set to correct DMX mode. Check number of channels required by fixture's DMX mode and check fixture addresses.
	Fixture defective.	Have faulty fixture serviced by Martin service technician.
	Other device on DMX link defective.	Bypass devices on DMX link until the faulty device has been identified. Have faulty device tested and serviced by Martin service technician or device supplier.
LEDs cut out intermittently.	Fixture is too hot.	Ensure free airflow around fixture. Clean fixture. Check that ambient temperature does not exceed maximum permitted level. Contact Martin for service.

**Table 2: Troubleshooting**



# Specifications

## Physical

Length	169 mm (6.7 in.) including cable gland
Width	307 mm (12.1 in.)
Height	401 mm (15.8 in.)
Weight	7.6 kg (16.8 lbs.) including bracket

## Dynamic Effects

Color mixing	RGBAW
Red	.0 - 100%
Green	.0 - 100%
Blue	.0 - 100%
Amber	.0 - 100%
White	.0 - 100%

## Control and Programming

Color control modes	RGBAW, RGB, HSI, HSIC
Control options	DMX, stand-alone, synchronized (master/slave)
DMX channels	3, 4 or 5
DMX address setting	PC with Martin MUM software and DABS1 hardware interface
Stand-alone trigger options	Internal timer and/or ambient light level
Stand-alone and master/slave programming	PC with Martin MUM software and DABS1
26-bit control (internal)	RGBAW, RGB, HSI, HSIC color mixing
Protocol	USITT DMX512-A
Receiver	RS-485
Firmware update	Serial upload via DMX link

## Photometric Data

Light source	Luxeon K2 high power emitters
Total output	1400 lm with narrow diffuser, balanced white 5600 K at 25° C (77° F)
Half-peak angle	21° with narrow diffuser
Minimum LED source lifetime (to 50% of initial output level)	30 000 hours at full intensity

## Construction

Color	Clear anodized or white, custom colors to special order
Housing	Anodized aluminum
Mounting bracket	.8 mm (0.3 in.) anodized aluminum
Front glass	6 mm (0.2 in.) anti-reflection coated
Protection rating	IP 65

## Installation

Orientation	Any
Vertical aiming	330°
Minimum distance to illuminated surfaces	0.1 m (0.3 ft.)

## Connections

Power cable entry	IP68 cable gland
Power connection	1.8 m (5.9 ft.) cable tail
Data cable entry	IP68 cable gland
Data connection	1.8 m (5.9 ft.) combined input + output cable tail

## Electrical

AC power	100-240 V nominal, 50/60 Hz
Power supply unit	Integrated, auto-sensing multi-voltage
Main fuse	2.5 AT (slow blow)

## Typical power and current

100 V, 50 Hz. ....	139 W, 1.4 A, PF = 0.990
100 V, 60 Hz. ....	139 W, 1.4 A, PF = 0.989
110 V, 60 Hz. ....	137 W, 1.3 A, PF = 0.988
120 V, 60 Hz. ....	136 W, 1.2 A, PF = 0.986
208 V, 60 Hz. ....	133 W, 0.7 A, PF = 0.932
230 V, 50 Hz. ....	132 W, 0.7 A, PF = 0.925
240 V, 50 Hz. ....	131 W, 0.7 A, PF = 0.886

Measurements made at nominal voltage with all LEDs at full intensity. Allow for a deviation of +/- 10%.

## Thermal

Cooling. ....	Convection
Maximum ambient temperature (Ta max.) ....	45° C (113° F)
Minimum ambient temperature (Ta min.) ....	-30° C (-22° F)
Maximum surface temperature, steady state, Ta=40° C ....	90° C (194° F)
Total heat dissipation (calculated, +/- 10%) ....	860 BTU/hr.

## Approvals



EU safety . . . . .	EN 60598-1, EN 60598-2-1, IEC/EN 60825-1
EU EMC . . . . .	EN 55103-1, EN 55103-2, EN 61000-3-2, EN 61000-3-3
US safety (US models). . . . .	UL 1598
Canadian safety (US models) . . . . .	CAN/CSA C.22.2 No. 250

## Included Items

- Adjustable mounting yoke
- Narrow diffuser (installed)
- Medium and Wide diffusers (supplied separately with product)
- User manual

## Accessories

Narrow beam angle kit (diffuser sheet) . . . . .	P/N 41600110
Medium beam angle kit (diffuser sheet). . . . .	P/N 41600111
Wide beam angle kit (diffuser sheet) . . . . .	P/N 41600112
Exterior 200 floor stand . . . . .	P/N 91611305
Safety eyebolt . . . . .	P/N 91611239
3-pin male XLR connector, cable-type, IP65 . . . . .	P/N 91611306
3-pin female XLR connector, cable-type, IP65. . . . .	P/N 91611307

## Spare parts

2.5 AT main fuse . . . . .	P/N 05020010
----------------------------	--------------

## Ordering Information

Exterior 200 LED, Aluminum, EU model . . . . .	P/N 90545000
Exterior 200 LED, Aluminum, US model . . . . .	P/N 90545100
Exterior 200 LED, White, EU model. . . . .	P/N 90545002
Exterior 200 LED, White, US model. . . . .	P/N 90545102

All models include Narrow diffuser installed and Medium and Wide diffusers supplied separately

Specifications subject to change without notice.

# Notes



---

[www.martin.com](http://www.martin.com) • Olof Palmes Allé 18 • 8200 Aarhus N • Denmark  
Tel: +45 8740 0000 • Fax +45 8740 0010