



DTW BAR 1000™

SKU# DTW392

The new DTW BAR 1000™ features (12) 10W multi-chip CW / WW / Amber LEDs, 28° beam angle, full color temperature range control (2,700K - 6,500K) plus independent Dim-to-Warm channel control (1,800K - 3,200K), pixel control, variable dimming curve modes, strobe and chase effects, ArtNet, KlingNet and RDM (remote device management) protocol support, DMX, RJ45, and power in/out connections, LCD menu display with 4 button control panel, integrated dual rigging brackets, multiple unit power linking, rugged die-cast aluminum exterior, frost filter and glare shield (included), flicker free operation for TV and FILM, and a multi-voltage universal auto switching power supply (110-240v).



FEATURES

12 x 10W Multi-Chip CW / WW/ Amber LEDs

28° Beam Angle

Pixel Control

Color Temperature Range Control (2,700K - 6,500K)

Dim-to-Warm Channel Control (1,800K - 3,200K)

ArtNet and KlingNet Support

RDM - Remote Device Management

Rugged Die-Cast Aluminum Exterior

Flicker Free Operation for TV and FILM



Frost Filter and Glare Shield Included

Specifications are subject to change without notice ©Elation Professional 07/05/16

Elation Professional USA | 6122 S. Eastern Ave. | Los Angeles, CA. 90040
323-582-3322 | 323-832-9142 fax | www.elationlighting.com | info@elationlighting.com

Elation Professional B.V. | Junostraat 2 | 6468 EW Kerkrade, The Netherlands
+31 45 546 85 66 | +31 45 546 85 96 fax | www.elationlighting.eu | info@elationlighting.eu

PRODUCT SPECIFICATIONS

SOURCE

(12) 10W Multi-Chip CW / WW / Amber LEDs
 100,000 Hour Average LED Life*

*LED Life may vary depending on several factors including but not limited to: Environmental Conditions, Power/Voltage, Usage Patterns (On-Off Cycling), Control and Dimming.

PHOTOMETRIC DATA

6,425 LUX 597 FC @3.3' (1m) (28° Full ON)
 3,196 LUX 297 FC @3.3' (1m) (38° Full ON w/Frost Filter)

EFFECTS

Pixel Control
 Strobe and Chase Effects
 Variable and Selectable Dimming Curves
 Independent Dim-to-Warm Channel Control (1.8K-3.2K)

CONTROL / CONNECTIONS

(12) DMX Channel Modes (1/2/3/5/6/7/10/12/14/36/41/45)
 4 Button Control Panel and LCD Menu Display
 RDM (Remote Device Management)
 ArtNet + KlingNET Protocol Support
 (2) etherCON RJ45 In/Out
 3pin and 5pin DMX In/Out
 powerCON Power In/Out

SIZE / WEIGHT

Length: 35.4" (900mm)
 Width: 8.1" (206.4mm) *with included glare shield
 Vertical Height: 6.1" (155mm)
 Weight: 14.0 lbs. (6.4 kg)

ELECTRICAL / THERMAL

AC 110-240V - 50/60Hz
 120W Max Power Consumption
 Power Linking: 7pcs Max @110V / 15pcs Max @240V
 5°F to 113°F (-15°C to 45°C)

APPROVALS / RATINGS



INCLUDED ITEMS

powerCON Cable
 Glare Shield
 Frost Filter

PHOTOMETRIC DATA

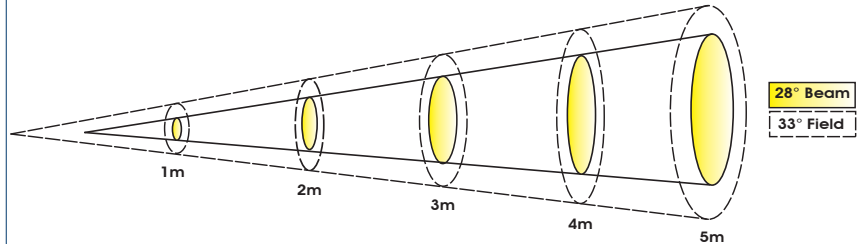

	1 m	3.3 ft	2 m	6.6 ft	3 m	9.8 ft	4 m	13.1 ft	5 m	16.4 ft
28° Beam Diameter	0.48	1.6	1.01	3.3	1.54	5.1	2.09	6.9	2.62	8.6
33° Field Diameter	0.59	1.9	1.23	4.0	1.86	6.1	2.48	8.1	3.12	10.2
	lux	fc	lux	fc	lux	fc	lux	fc	lux	fc
CW LEDs	3,561	331	1,603	149	905	84	584	54	382	35
WW LEDs	3,447	320	1,587	147	872	81	550	51	379	35
AMBER LEDs	1,166	108	589	55	318	30	201	19	138	13
FULL ON	6,425	597	2,975	276	1,625	151	999	93	686	64

DIMENSIONAL DIAGRAMS

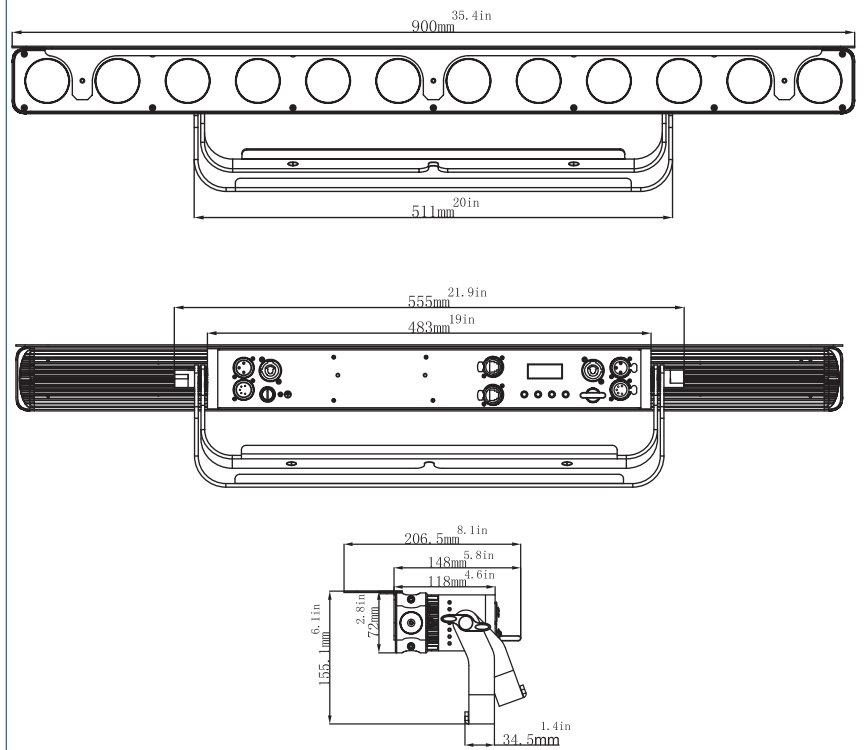

OPTIONAL ACCESSORIES

ORDER CODE	ITEM
TRIGGER CLAMP	Heavy Duty Wrap Around Hook Style Clamp
PLC3	3' (1m) powerCON PRO Link Cable
AC3PDMX5PRO	5 ft. (1.5m) 3pin PRO DMX Cable
AC5PDMX5PRO	5 ft. (1.5m) 5pin PRO DMX Cable
CAT005	5' (1.5m) CAT6 etherCON Cable
	Additional cable lengths available



Specifications are subject to change without notice ©Elation Professional 07/05/16

Elation Professional USA | 6122 S. Eastern Ave. | Los Angeles, CA. 90040
 323-582-3322 | 323-832-9142 fax | www.elationlighting.com | info@elationlighting.com

Elation Professional B.V. | Junostraat 2 | 6468 EW Kerkrade, The Netherlands
 +31 45 546 85 66 | +31 45 546 85 96 fax | www.elationlighting.eu | info@elationlighting.eu