



ACL CURTAIN™

SKU# ACL035

The new ACL CURTAIN™ is a versatile batten luminaire featuring (14) individual 15W RGBW 4-in-1 LEDs and the new advanced collimator optic lens producing a laser-like homogenized 4° color-changing beam from each lens which combined produce a 53° beam angle. Features include full individual pixel control, strobe, and selectable dimming curve effects, DMX, RDM (Remote Device Management), KlingNET™ and Art-NET support, 3/5pin XLR, powerCON, and RJ45 ethernet in/out connections, (4) button control full color 180° reversible menu display, 135W max power consumption, a multi-voltage universal auto switching power supply (100-240v), and included glare shield and frost filter.



FEATURES

Versatile 53° Beam Bar Luminaire

New Advanced Collimator Optic Lens

(14) Pixel Controlled 15W RGBW 4-in-1 LEDs

Laser-Like Homogenized 4° Color Changing Beams

Strobe and Selectable Dimming Curve Effects

DMX, KlingNET™ and Art-NET (DMX Over Ethernet)

Flicker Free Operation for Broadcast TV and FILM

Glare Shield and Frost Filter Included



Glare Shield + Frost Filter Installed



Specifications are subject to change without notice ©Elation Professional 09/30/15

Elation Professional USA | 6122 S. Eastern Ave. | Los Angeles, CA. 90040
323-582-3322 | 323-832-9142 fax | www.elationlighting.com | info@elationlighting.com

Elation Professional B.V. | Junostraat 2 | 6468 EW Kerkrade, Netherlands
+31 45 546 85 66 | +31 45 546 85 96 fax | www.elationlighting.eu | info@elationlighting.eu

PRODUCT SPECIFICATIONS

SOURCE

(14) 15W RGBW 4-in-1 LEDs
100,000 Hour Average LED Life*

*LED Life may vary depending on several factors including but not limited to: Environmental Conditions, Power/Voltage, Usage Patterns (On-Off Cycling), Control and Dimming.

PHOTOMETRIC DATA (53° Full ON)

46,740 LUX 4,342 FC @3.3' (1m)
20,890 LUX 1,941 FC @6.6' (2m)
13,520 LUX 1,256 FC @9.8' (3m)
9,717 LUX 903 FC @13.1' (4m)
7,664 LUX 712 FC @16.4' (5m)

EFFECTS

Individual Pixel Control
Strobe and Selectable Dimming Curves

COLOR

RGBW

CONTROL / CONNECTIONS

(11) DMX Channel Modes:
(1CH:04 / 2CH:04 / 6 / 1CH:08 / 2CH:08 / 10 / 12 / 56 / 58 / 60 / 63)
RDM (Remote Device Management)
4 Button Touch Control Panel
Full Color 180° Reversible LCD Menu Display
3pin/5pin DMX In/Out
RJ45 Ethernet In/Out (KlingNET™ / Art-NET)
powerCON Power In/Out

SIZE / WEIGHT

Length: 43.3" (1100mm)
Width: 9.5" (241.2mm) (Glare Shield Installed)
Vertical Height: 6.8" (172.5mm)
Weight: 24.0 lbs. (10.9 kg)

ELECTRICAL / THERMAL

AC 100-240V - 50/60Hz
240W Max Power Consumption
Power Linking: 4pcs Max @110V / 9pcs Max @240V
5F to 113°F (-15°C to 45°C)

APPROVALS / RATINGS

CE | IP30

INSTALLATION

Rigging: Clamps (Not Included)
Working Position: Any (360°)

INCLUDED ITEMS

powerCON Cable
Glare Shielded
Frost Filter

PHOTOMETRIC DATA

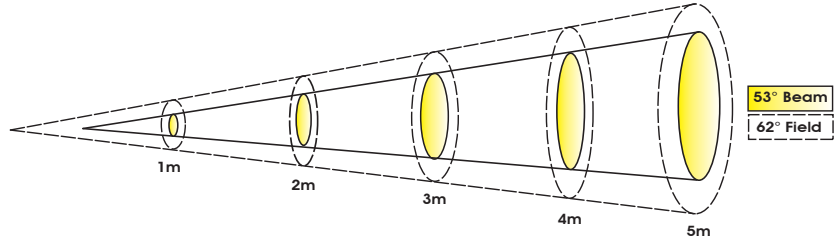

	1 m	3.3 ft	2 m	6.6 ft	3 m	9.8 ft	4 m	13.1 ft	5 m	16.4 ft
53° Beam Diameter	0.98	3.2	1.94	6.4	2.95	9.7	3.95	13.0	4.91	16.1
62° Field Diameter	1.17	3.8	2.39	7.8	3.58	11.7	4.7	15.4	5.85	19.2
	lux	fc	lux	fc	lux	fc	lux	fc	lux	fc
RED LEDs	7,902	734	3,652	339	2,440	227	1,757	163	1,313	122
GREEN LEDs	18,770	1,744	9,134	849	5,740	533	4,040	375	2,971	276
BLUE LEDs	4,537	421	1,924	179	1,337	124	951	88	761	71
WHITE LEDs	19,590	1,820	11,330	1,053	6,714	624	5,064	470	3,855	358
FULL ON	46,740	4,342	20,890	1,941	13,520	1,256	9,717	903	7,664	712

DIMENSIONAL DIAGRAMS

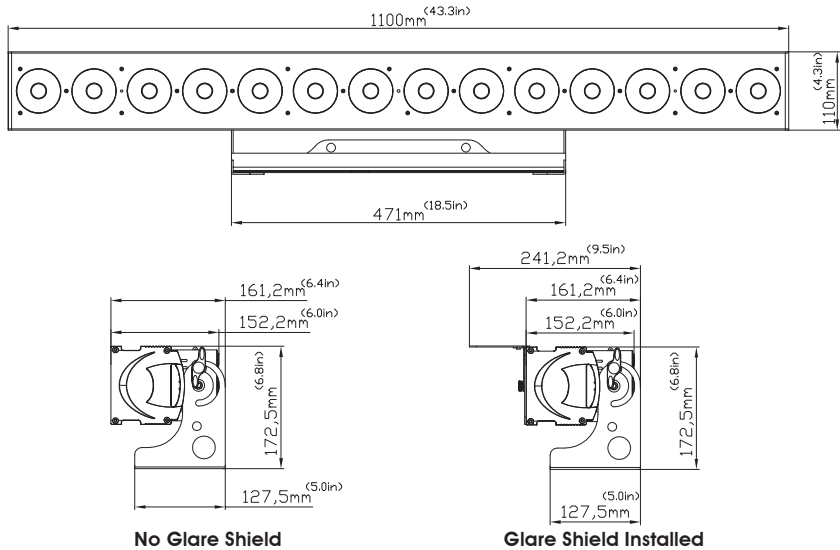

OPTIONAL ACCESSORIES

ORDER CODE	ITEM
TRIGGER CLAMP	Heavy Duty Wrap Around Hook Style Clamp
EWDMSYSTEM	Wireless DMX System (1 Transmitter, 1 Receiver)
PLC3	3' (1m) PowerCON PRO Link Cable
CAT6PRO5	5' (1.5m) CAT6 EtherCON Cable
AC5PDMX5PRO	5 ft. (1.5m) 5pin PRO DMX Cable
	Additional cable lengths available

