

**ROBE**

Color Wash **1200€**<sup>AT</sup>

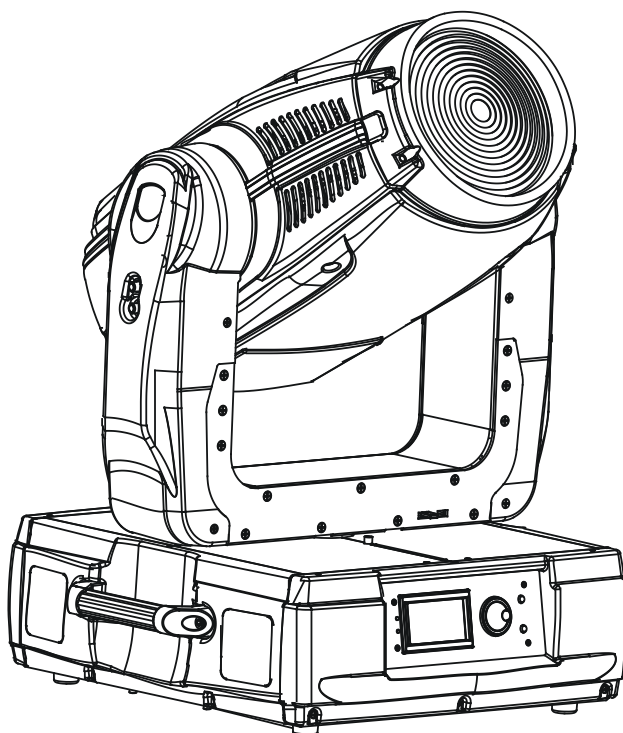

**AT** SERIES

USER MANUAL

*Version: 5.0*

ROBE® Lighting s.r.o. • Czech Republic • [www.robe.cz](http://www.robe.cz)



# Color Wash | 200E<sup>AT</sup>

## *Table of contents*

<b>1. Unpacking</b>	<b>4</b>
<b>2. Safety instructions</b>	<b>4</b>
<b>3. Operating determinations</b>	<b>5</b>
<b>4. Description of the fixture</b>	<b>6</b>
<b>5. Installation</b>	<b>8</b>
<i>5.1 Connection to the mains</i>	<i>8</i>
<i>5.2 Changing the power supply settings</i>	<i>8</i>
<i>5.3 Fitting the lamp</i>	<i>9</i>
<i>5.4 Lamp adjustment</i>	<i>9</i>
<i>5.5 Inserting/Exchanging colours</i>	<i>10</i>
<i>5.6 Changing the front lenses</i>	<i>10</i>
<i>5.7 Installing top hats</i>	<i>11</i>
<i>5.8 Rigging the fixture</i>	<i>11</i>
<i>5.9 DMX-512 connection/connection between fixtures</i>	<i>13</i>
<i>5.10 Ethernet connection</i>	<i>13</i>
<b>6. DMX Protocol</b>	<b>15</b>
<b>7. Controller mode</b>	<b>19</b>
<i>7.1 DMX addressing</i>	<i>19</i>
<i>7.2 Remotely controllable functions</i>	<i>19</i>
<b>8. Control menu map</b>	<b>20</b>
<b>9. Control menu</b>	<b>24</b>
<i>9.1 Fixture Address</i>	<i>24</i>
<i>9.2 Fixture informations</i>	<i>24</i>
<i>9.3 Personality</i>	<i>26</i>
<i>9.4 Lamp On/Off</i>	<i>28</i>
<i>9.5 Test sequences</i>	<i>28</i>
<i>9.6 Manual mode</i>	<i>28</i>
<i>9.7 Stand-alone setting</i>	<i>28</i>
<i>9.8 Reset functions</i>	<i>29</i>
<i>9.9 Special functions</i>	<i>29</i>
<b>10. Power down mode</b>	<b>30</b>
<b>11. RDM</b>	<b>31</b>
<b>12. Error and information messages</b>	<b>32</b>
<b>13. Technical specifications</b>	<b>33</b>
<b>14. Maintenance and cleaning</b>	<b>37</b>

# 1. Unpacking

## The ColorWash 1200E AT cardboard box included items:

- ColorWash 1200E AT
  - Wide-angle lens (1piece)
  - User manual (1piece)
  - Small paper box with Mounting bracket Omega CL assembled (2 pieces)
- The small paper box is situated in the top part of the cardboard box.

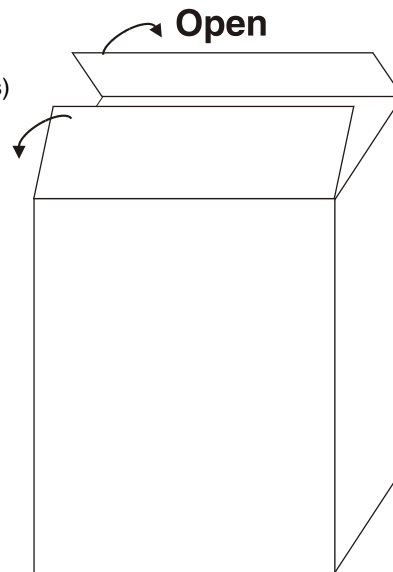

**CAUTION!** *Keep this device away from rain and moisture!  
Unplug mains lead before opening the housing!*

**FOR YOUR OWN SAFETY, PLEASE READ THIS USER MANUAL CAREFULLY  
BEFORE YOU INITIAL START - UP!**

## 2. Safety instructions

Every person involved with installation and maintenance of this device have to:

- be qualified
- follow the instructions of this manual

**CAUTION!** *Be careful with your operations.  
With a high voltage you can suffer a dangerous electric shock  
when touching the wires!*

This device has left our premises in absolutely perfect condition. In order to maintain this condition and to ensure a safe operation, it is absolutely necessary for the user to follow the safety instructions and warning notes written in this manual.

### Important:

The manufacturer will not accept liability for any resulting damages caused by the non-observance of this manual or any unauthorized modification to the device.

Please consider that damages caused by manual modifications to the device are not subject to warranty.

Never let the power-cord come into contact with other cables! Handle the power-cord and all connections with the mains with particular caution!

Make sure that the available voltage is not higher than stated on the rear panel.

Always plug in the power plug least. Make sure that the power-switch is set to off-position before you connect the device to the mains. The power-plug has to be accessible after installing the device.

Make sure that the power-cord is never crimped or damaged by sharp edges. Check the device and the power-cord from time to time.

Always disconnect from the mains, when the device is not in use or before cleaning it. Only handle the power-cord by the plug. Never pull out the plug by tugging the power-cord.

This device falls under protection class I. Therefore it is essential to connect the yellow/green conductor to earth.

The electric connection, repairs and servicing must be carried out by a qualified employee.  
Do not connect this device to a dimmer pack.

Do not switch the fixture on and off in short intervals as this would reduce the lamp's life.

During the initial start-up some smoke or smell may arise. This is a normal process and does not necessarily mean that the device is defective.

Do not touch the device's housing bare hands during its operation (housing becomes hot)!  
For replacement use lamps and fuses of same type and rating only.

**CAUTION!**     ***Avoid looking directly into the light source***  
**EYEDAMAGES!**     ***(meant especially for epileptics)!***

### 3. Operating determinations

This device is a moving-head spot for creating decorative effects and was designed for indoor use only.

If the device has been exposed to drastic temperature fluctuation (e.g. after transportation), do not switch it on immediately. The arising condensation water might damage your device. Leave the device switched off until it has reached room temperature.

Never run the device without lamp!

Do not shake the device. Avoid brute force when installing or operating the device.

Never lift the fixture by holding it at the projector-head, as the mechanics may be damaged. Always hold the fixture at the transport handles.

When choosing the installation-spot, please make sure that the device is not exposed to extreme heat, moisture or dust. There should not be any cables lying around. You endanger your own and the safety of others!

The minimum distance between light-output and the illuminated surface must be more than 4 meters.

Make sure that the area below the installation place is blocked. Always fix the fixture with an appropriate safety rope. Fix the safety rope at the correct holes only.

Only operate the fixture after having checked that the housing is firmly closed and all screws are tightly fastened.

The lamp must never be ignited if the objective-lens or any housing-cover is open, as discharge lamps may explode and emit a high ultraviolet radiation, which may cause burns.

The maximum ambient temperature 40° C must never be exceeded. Otherwise, the lamp is switched off and the fixture is out of operation for 5 minutes.

**CAUTION!**     ***The lens has to be replaced when it is obviously damaged, so that its function is impaired, e. g. due to cracks or deep scratches!***

Operate the device only after having familiarized with its functions. Do not permit operation by persons not qualified for operating the device. Most damages are the result of unprofessional operation!

**CAUTION!**     ***The lamp has to be replaced when it is damaged or deformed due to the heat!***

Please use the original packaging if the device is to be transported.

Please consider that unauthorized modifications on the device are forbidden due to safety reasons!

If this device will be operated in any way different to the one described in this manual, the product may suffer damages and the guarantee becomes void. Furthermore, any other operation may lead to dangers like short-circuit, burns, electric shock, burns due to ultraviolet radiation, lamp explosion, crash etc.

**CAUTION!**     ***The head and yoke must be unlocked before operation!***  
***Check the pan/tilt locks!***

## 4. Description of the fixture

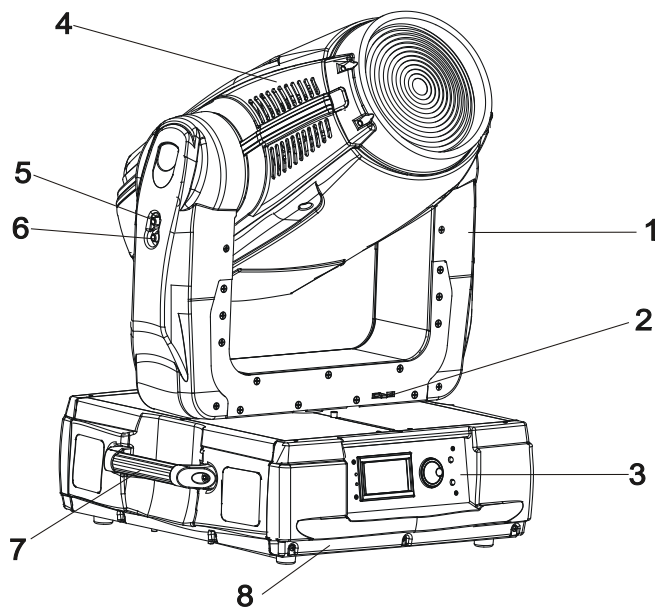

- 1 - Yoke
- 2 - Pan lock/unlock lever
- 3 - Front panel
- 4 - Moving head
- 5 - Tilt lock button (red)
- 6 - Tilt unlock button (green)
- 7 - Handle
- 8 - Base

The head can be locked for transportation- the tilt lock button (5) is pushed and the pan lock/unlock lever (2) is in lock position. To unlock the head, press the tilt unlock button (6) and move the pan lock/unlock lever (2) to unlock position.

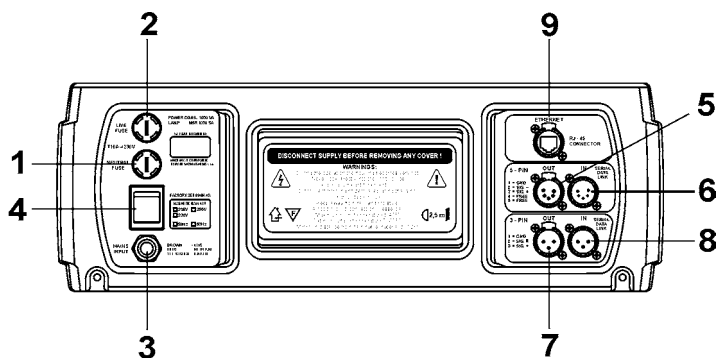

### Rear panel of the base

- 1 - Neutral fuse holder
- 2 - Live fuse holder
- 3 - Power cord
- 4 - Power switch
- 5 - 5-pin DMX output
- 6 - 5-pin DMX input
- 7 - 3-pin DMX output
- 8 - 3-pin DMX input
- 9 - Ethernet input

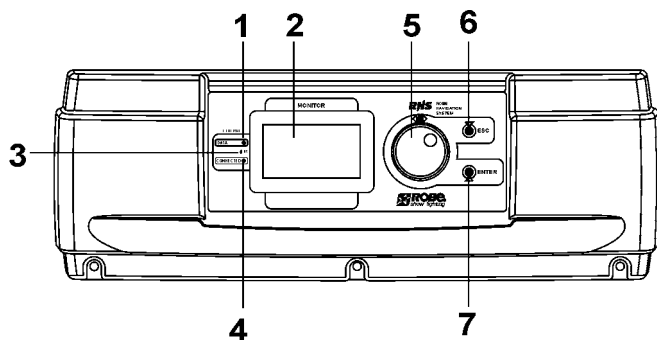

### Front panel of the base

- 1 - Network indicator
- 2 - Display
- 3 - Infra-red sensor
- 4 - Data-transfer indicator
- 5 - RNS encoder wheel
- 6 - Escape button
- 7 - Enter button

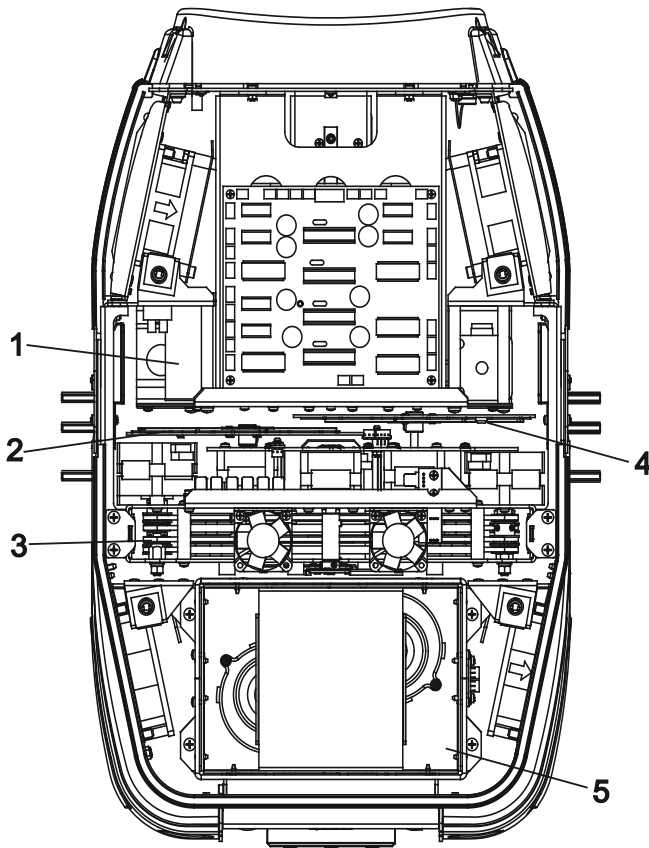

**Head inside-top side**

- 1 - Igniter
- 2 - Colour wheel 1
- 3 - CMY/conver.filter module
- 4 - Colour wheel 2
- 5 - Lamp chamber

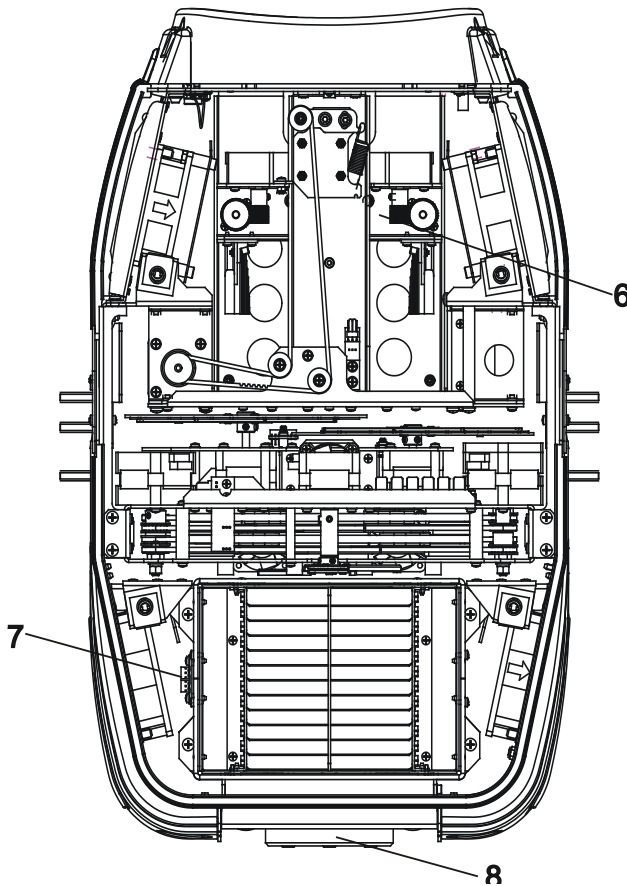

**Head inside-bottom side**

- 6 - Inside Fresnel lens
- 7 - Termostat
- 8 - Lamp cover

## 5. Installation



**Fixtures must be installed by a Qualified electrician in accordance with all national and local electrical and construction codes and regulation.**

### 5.1 Connection to the mains

**Verify the power supply settings before applying power!**

The factory settings are printed next to the power switch. If you wish to change the power supply settings, see the next chapter.

Install a 3-prong grounding-type plug on the power cable (US version). The earth has to be connected! If you have any doubts about proper installation, consult a qualified electrician.

The occupation of the connection-cables is as follows:

Cable (EU)	Cable (US)	Pin	International
Brown	Black	Live	L
Liht blue	White	Neutral	N
Yellow/Green	Green	Earth	

### 5.2 Changing the power supply settings

#### Electronic ballast

The operating range of the electronic ballast is 95 VAC-255 VAC. The transformer has to be set to the local AC voltage.

If you want to change the power supply settings, follow the instructions:

1. Disconnect the fixture from AC power.
2. Remove the both top base covers by loosening the 14 screws.
3. Move the wire (3) on the transformer connection block to the position according to the desired voltage.
4. Close the base before applying AC power.

#### Transformer connection:

Power supply settings: 120V/60Hz

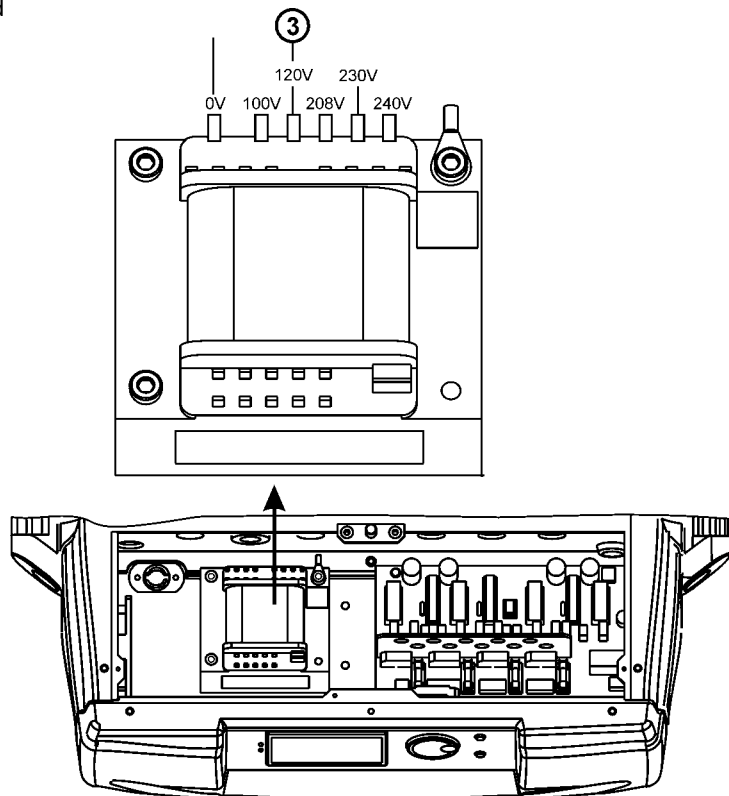



## 5.3 Fitting the lamp

**DANGER ! Install the lamps with the device switched off only.  
Unplug from mains before !**

**To insert the lamp (MSR 1200 SA):**

1. Disconnect the fixture from power and allow it to cool.
2. Loosen the 2 quarter-turn fasteners marked „X, Y,” on the lamp cover at the back of the head.
3. Gently pull the lamp cover with lamp holder out of the head.
4. Holding the lamp by its ceramic base, carefully pull the lamp straight out of the lamp socket.
5. Holding the new lamp by its ceramics base, gently insert the lamp to the lamp socket. Make sure that the lamp is installed tightly into the lamp socket.  
Do not install a lamp with a higher wattage! A lamp like this generates temperatures the device is not designed for. Damages caused by non-observance are not subject to warranty. Please follow the lamp manufacturer's notes! Do not touch the glass bulb bare hand during the installation!
6. Reinsert the lamp cover with the lamp holder and installed lamp back to the head and tighten the 2 quarter-turn fasteners again.

**Warning:** if you feel any resistance during this action, check the lamp electrode position and use „A,B,C” screws to adjust right lamp position. Never put the lamp in by force otherwise you will bend the lamp electrode by the edge of the reflector! (See picture bellow)

7. Align the new lamp.
8. Reset „Lamp On Time” and „Lamp Strikes” counters in „Fixture information” menu.

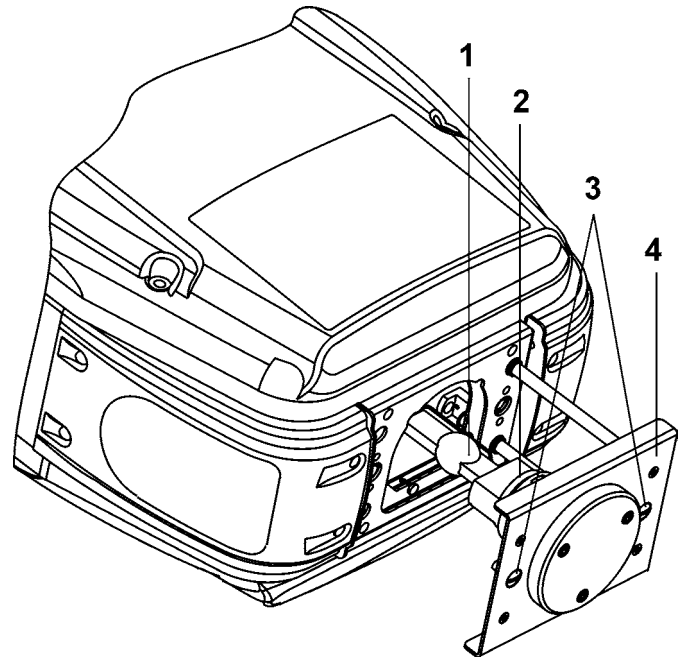

- 1 - Lamp
- 2 - Lamp holder
- 3 - 2 quarter-turn fasteners
- 4 - Lamp cover

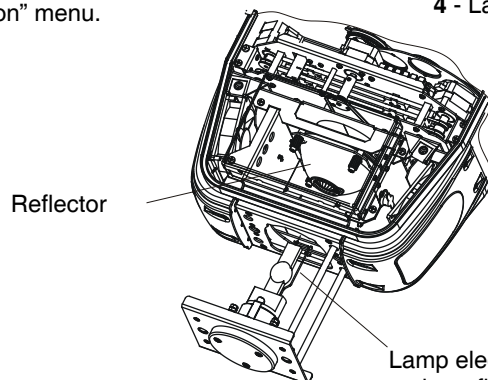

Lamp electrode-check its position before insertion to the reflector

**Do not operate this fixture with opened housing-cover!**

## 5.4 Lamp adjustment

The lamp holder is aligned at the factory.

Due to differences between lamps, fine adjustment may improve light performance:

1. Switch on the fixture and after reset turn on the lamp.
2. Cancel all effects, open the shutter and focus the light on a flat surface (wall) using either DMX controller or function „Lamp adjustment” in „Special functions menu”.
3. Center the hot-spot (the brightest part of the beam) using the 3 adjustment screws „A, B, C”. Turn one screw at a time to drag the hot-spot, diagonally across the projected image. If you cannot detect a hot-spot, adjust the lamp until the light is even.

To reduce a hot-spot, pull the lamp in by turning all three screws „A, B, C” clockwise 1/4-turn at a time until the light is evenly distributed.

If the light is brighter around the edge than it is in the center, or if light output is low, the lamp is too far back in the reflector. „Push” the lamp out by turning the screws „A, B, C” counter-clockwise 1/4-turn at a time until the light is bright and evenly distributed.

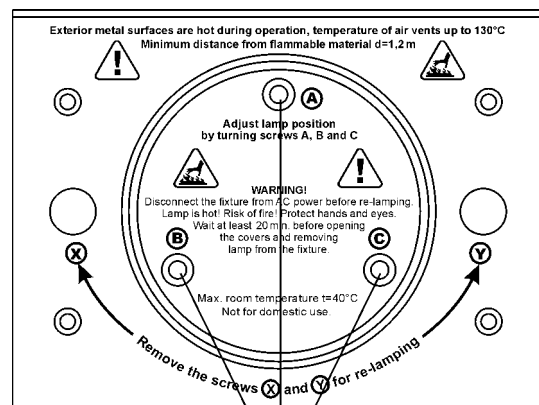

3 adjustment screws „A, B, C”

## 5.5 Inserting/Exchanging colours

**DANGER!** *Install the colours with the device switched off only.  
Unplug from mains before!*

Turn off the lamp and allow it to cool for at least 10 minutes. Disconnect the fixture from power.

Open the bottom cover of the moving head by loosening the 4 quarter-turn fasteners on the top cover and follow the instructions below:

1. Gently bend out the colour module to release it from the fixative holes and eject it from the pressing snap.
2. Put the new colour module back under the pressing snap and push it to the 3 fixative notches.

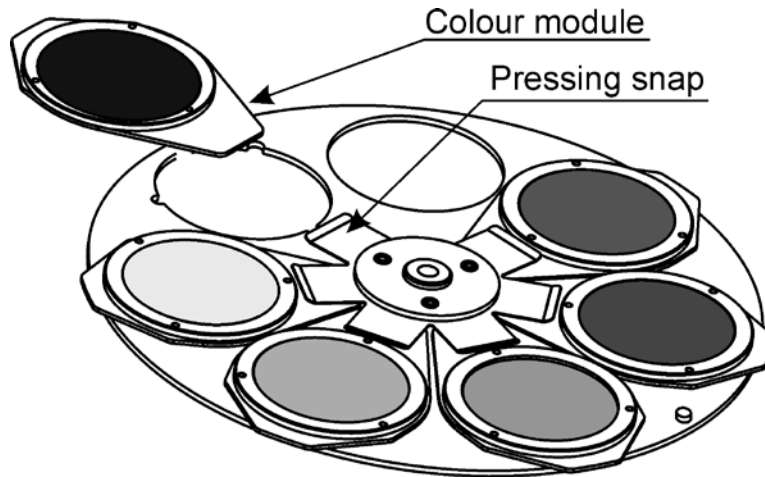

## 5.6 Changing the front lenses

The ColorWash 1200E AT is supplied with the 2 types of the front lenses (Fresnel lens, wide-angle lens) and the Fresnel lens is installed as standard.

**Switch the device off before changing the lens. Be careful. Front lens is very heavy!**

If you want to change the front lens, follow the instructions:

1. Remove the front lens using a flathead screwdriver to unlock the four quarter-turn screws.
2. Unscrew the safety cable from the lens
3. Screw up the safety cable to the desired lens.
4. Place this lens and fix it by locking the four quarter-turn screws.

Quarter-turn screws

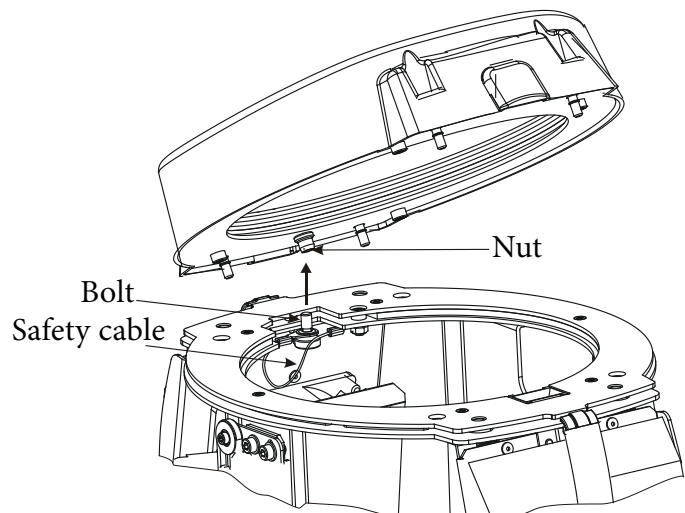
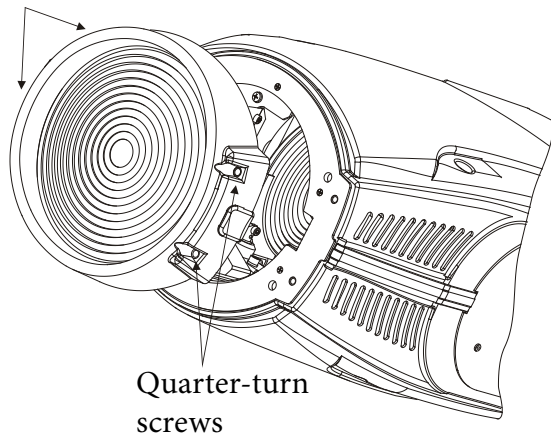

## 5.7 Installing top hats

The ColorWash 1200E AT can be fitted with various types of the top hats-see chapter "Technical specifications".If you wish to install a top hat (optional),follow the instructions:

**Switch the device off before installing the top hat!**

Installing the top hat on the front lens-holder of the fixture:

1. Loosen 4 lens holder quarter-turn screws and hook both securing springs to the plastic projections in the front lens-holder. Tighten the 4 lens holder quarter-turn screws again.
2. Put desired top hat onto a front lens-holder and fasten it by two fastening screws.
3. Snap both springs to the slots in the top hat.

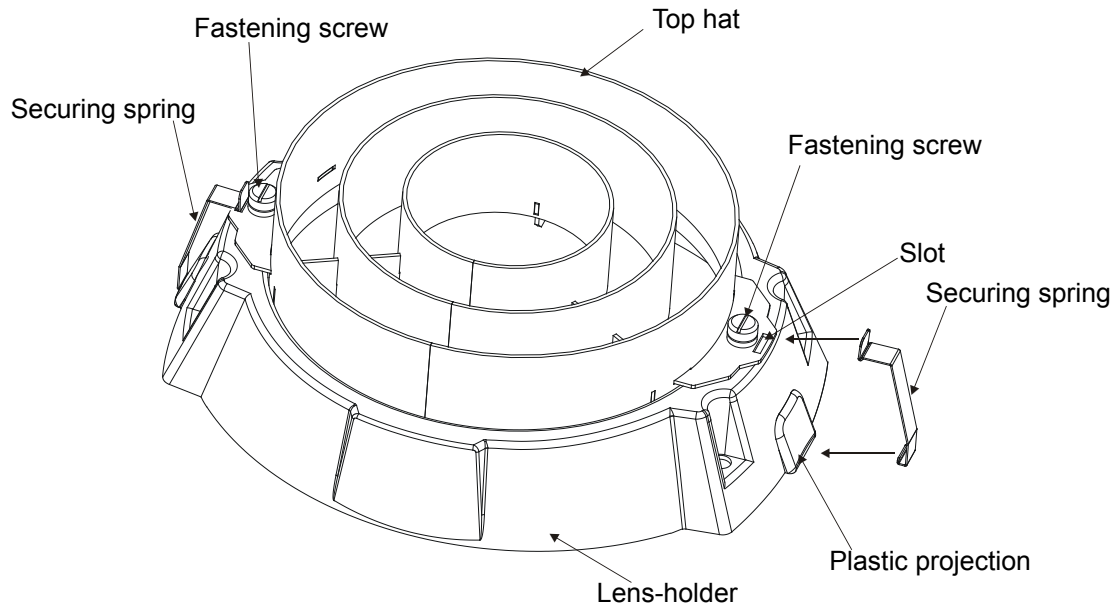

## 5.8 Rigging the fixture

**DANGER TO LIFE!**

**Please consider the respective national norms during the installation!**

The installation of the fixture has to be built and constructed in a way that it can hold 10 times the weight for 1 hour without any harming deformation.

The installation must always be secured with a secondary safety attachment, e.g. an appropriate catch net. This secondary safety attachment must be constructed in a way that no part of the installation can fall down if the main attachment fails.

When rigging, derigging or servicing the fixture staying in the area below the installation place, on bridges, under high working places and other endangered areas is forbidden.

The operator has to make sure that safety-relating and machine-technical installations are approved by an expert before taking into operation for the first time and after changes before taking into operation another time.

The operator has to make sure that safety-relating and machine-technical installations are approved by an expert after every four year in the course of an acceptance test.

The operator has to make sure that safety-relating and machine-technical installations are approved by a skilled person once a year.

Allow the fixture to cool for ten minutes before handling.

The projector should be installed outside areas where persons may walk by or be seated.

**IMPORTANT! OVERHEAD RIGGING REQUIRES EXTENSIVE EXPERIENCE**, including calculating working load limits, installation material being used, and periodic safety inspection of all installation material and the projector. If you lack these

qualifications, do not attempt the installation yourself, but instead use a professional structural rigger. Improper installation can result in bodily injury and or damage to property.

The fixture has to be installed out of the reach of people.

If the fixture shall be lowered from the ceiling or high joists, professional trussing systems have to be used. The fixture must never be fixed swinging freely in the room.

**Caution:** Fixtures may cause severe injuries when crashing down! If you have doubts concerning the safety of a possible installation, do not install the fixture!

Before rigging make sure that the installation area can hold a minimum point load of 10 times the fixture's weight.

**Danger of fire!**

**When installing the device, make sure there is no highly inflammable material (decoration articles, etc.) in between a distance of min. 1.2 m.**

**CAUTION! Use 2 appropriate clamps to rig the fixture on the truss. Follow the instructions mentioned at the bottom of the base.**

**Make sure that the device is fixed properly!**

**Ensure that the structure (truss) to which you are attaching the fixtures is secure.**

The moving-head can be placed directly on the stage floor or rigged in any orientation on a truss without altering its operation characteristics .

The Omega holders can be placed in 4 positions on the bottom of the base. Use the clamps (not included in delivery) with screws M12.

For overhead use, always install a safety-rope that can hold at least 10 times the weight of the fixture. You must only use safety ropes with screw-on carabines. Pull the safety rope through the two apertures on the bottom of the base and over the trussing system etc. Insert the end in the carabine and tighten the fixation screw.

**Fixation via the omega holders**

1. Bolt each clamp (1) to the omega holder (4) with M12 bolt and lock nut through the hole in the holder.
2. Fasten the omega holders on the bottom of the base by inserting both quick-lock fasteners (3) into the holes of the base and tighten fully clockwise.
3. Fasten the safety-rope (2) through the two apertures on the bottom of the base and over the trussing system.

- 1 - Clamp
- 2 - Safety-rope
- 3 - Quick-lock fastener
- 4 - Omega holder

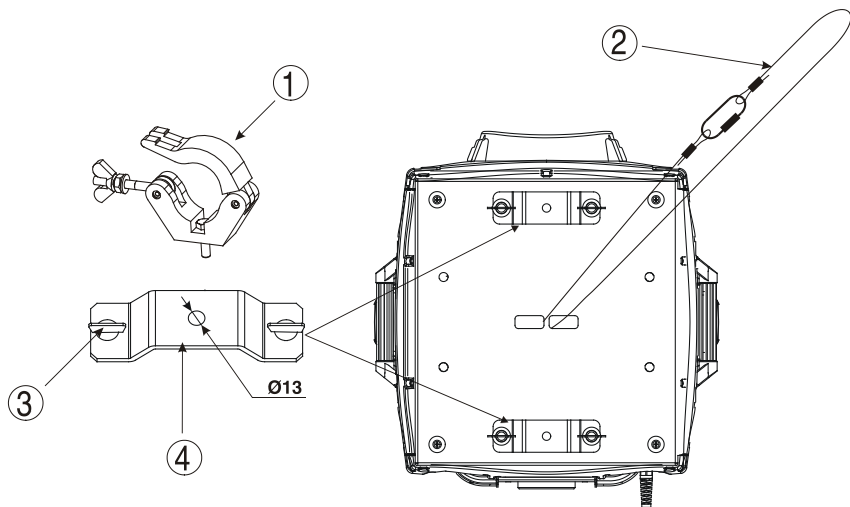

**Possible omega holder 4 positions (dimensions in mm):**

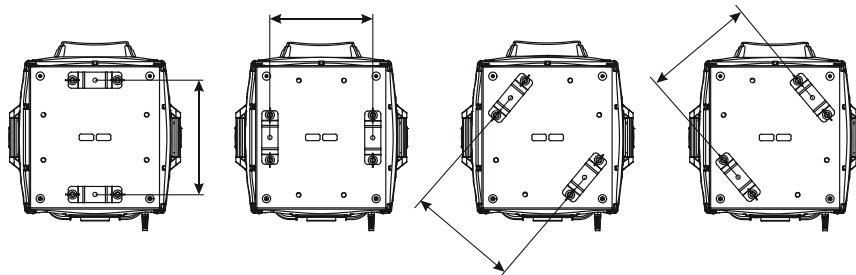

**When installing fixtures side-by-side, avoid illuminating one fixture with another!**

**DANGER TO LIFE! Before taking into operation for the first time, the installation has to be approved by an expert!**

## 5.9 DMX-512 connection/connection between fixtures

The fixture is equipped with both 3-pin and 5-pin XLR sockets for DMX input and output. The sockets are wired in parallel. Only use a shielded twisted-pair cable designed for RS-485 and 3-pin or 5-pin XLR-plugs and connectors in order to connect the controller with the fixture or one fixture with another.

### Occupation of the XLR-connection:

**DMX - output**  
XLR mounting-sockets (rear view):

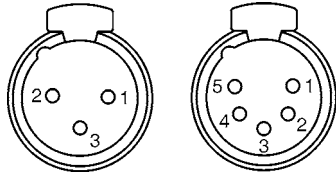

- 1 - Shield
- 2 - Signal (-)
- 3 - Signal (+)
- 4 - Not connected
- 5 - Not connected

**DMX-input**  
XLR mounting-plugs (rear view):

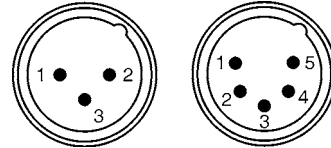

If you are using the standard DMX controllers, you can connect the DMX output of the controller directly with the DMX input of the first fixture in the DMX chain. If you wish to connect DMX controllers with other XLR outputs, you need to use adapter-cables.

### Building a serial DMX chain:

Connect the DMX output of the first fixture in the DMX chain with the DMX input of the next fixture. Always connect one output with the input of the next fixture until all fixtures are connected.

**Caution:** At the last fixture, the DMX cable has to be terminated with a terminator. Solder a 120 Ω resistor between Signal (-) and Signal (+) into a XLR plug and plug it in the DMX output of the last fixture.

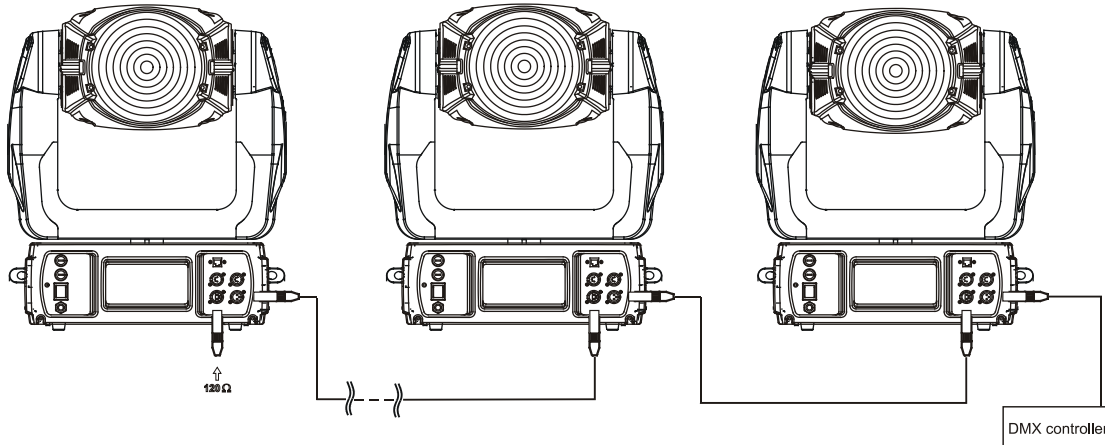

## 5.10 Ethernet connection

The fixtures on a data link are connected to the Ethernet with Art-Net communication protocol. The controlling software from PC (or lighting console) has to support Art-Net protocol.

Art-Net communication protocol is a 10 Base T Ethernet protocol based on the TCP/IP. Its purpose is to allow transfer of large amounts of DMX 512 data over a wide area using standard network technology.

**IP address** is the Internet protocol address. The IP uniquely identifies any node (fixture) on a network.

**The Universe** is a single DMX 512 frame of 512 channels.

The ColorWash 1200E AT is equipped with 8-pin RJ-45 socket for Ethernet input. Use a network cable category 5 (with four „twisted” wire pairs) and standard RJ-45 plugs in order to connect the fixture to the network.

**RJ-45 socket (front view):**

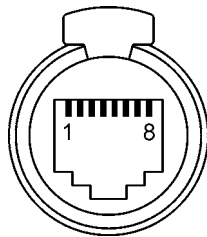

- 1- TD+
- 2- TD-
- 3- RX+
- 4- Not connected
- 5- Not connected
- 6- RX-
- 7- Not connected
- 8- Not connected

Patch cables that connect fixtures to the hubs or LAN sockets are wired 1:1, that is, pins with the same numbers are connected together:

pin	1	2	3	4	5	6	7	8
pin	1	2	3	4	5	6	7	8

If only the fixture and the computer are to be interconnected, no hubs or other active components are needed. A cross-cable has to be used:

pin	1	2	3	4	5	6	7	8
pin	3	6	1	8	7	2	5	4

### Ethernet connection

Connect the Ethernet-inputs of all fixtures in the fixture chain with the network.  
 Option "Ethernet" has to be selected from „Set Ethernet Mode" menu on the fixture.  
 Set IP address (002.xxx.xxx.xxx / 010.xxx.xxx.xxx) and the Universe.

#### Example:

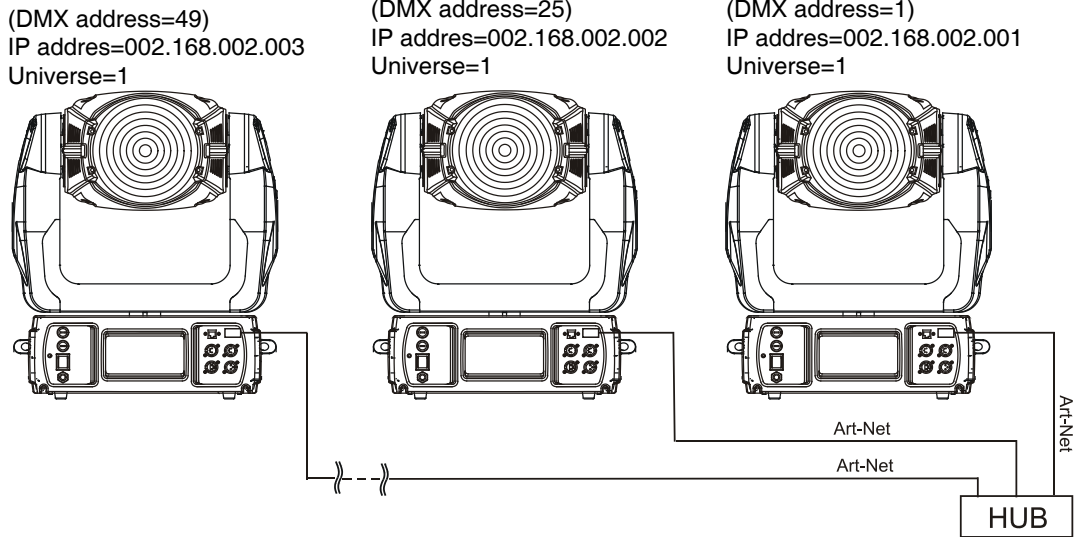

**An advised PC setting:** IP address: 002.xxx.xxx.xxx / 010.xxx.xxx.xxx (Different from fixture IP addresses)  
 NET mask: 255.0.0.0

### Ethernet / DMX connection

Options „Ethernet/DMX" has to be selected from „Set Ethernet Mode" menu on the first fixture (connected to the network) in the fixture chain, next fixtures have standard DMX addresses.  
 Connect the Ethernet-input of the first fixture in the data chain with the network. Connect the DMX output of this fixture with the input of the next fixture until all fixtures are connected to the DMX chain.

**Caution:** At the last fixture, the DMX chain has to be terminated with a terminator. Solder a 120 Ω resistor between Signal (-) and Signal (+) into a XLR-plug and connect it in the DMX-output of the last fixture.

#### Example:

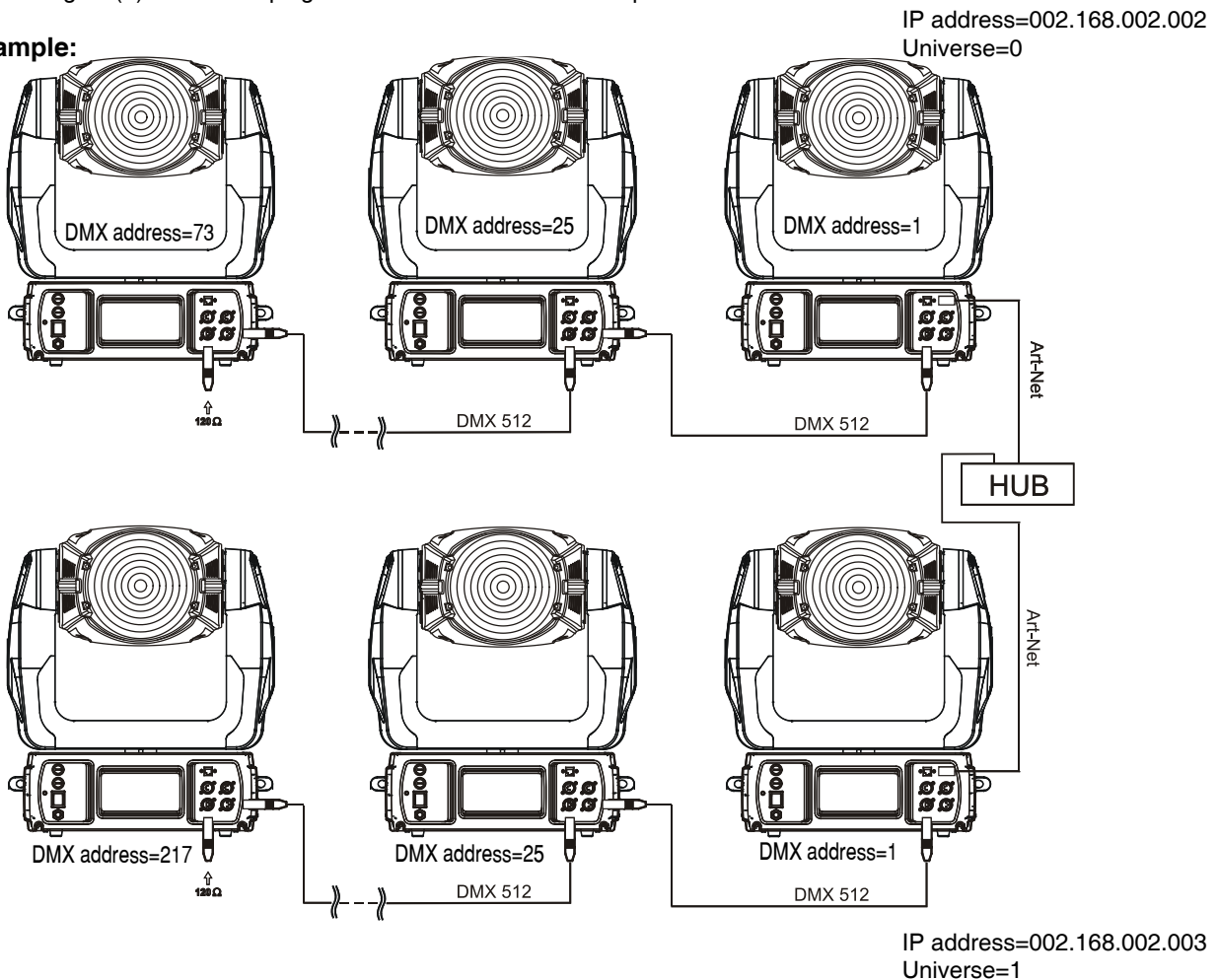

## 6.DMX Protocol

Mode/Channel					Value	Function	Type of control
1	2	3	4	5			
1	1	1	1	16	0 - 255	<b>Pan</b> Pan movement by 530°	proportional
2	2	2	2	17	0 - 255	<b>Pan Fine</b> Fine control of pan movement	proportional
3	3	3	3	18	0 - 255	<b>Tilt</b> Tilt movement by 280°	proportional
4	4	4	4	19	0 - 255	<b>Tilt fine</b> Fine control of tilt movement	proportional
5	5	5	5	20	0	<b>Pan/Tilt speed , Pan/Tilt time</b> Max. speed (tracking mode)*	step
					1 - 255	<b>P./T. speed-set Speed Mode in menu: Pan/Tilt Mode</b> Speed from max. to min. (vector mode)**	proportional
					1 - 255	<b>P./T. time - set Time Mode in menu: Pan/Tilt Mode</b> Time from 0,1 s to 25,5 s. ***	proportional
6	6	6	6	21	0 - 49	<b>Power/Special functions</b> Reserved <i>To activate following functions, stop in DMX value for at least 3 s and shutter must be closed at least 3 s. („Shutter,Strobe” channel 16 (21,23,28,1) must be at range: 0-31 DMX).****</i>	step
					50 - 59	Pan/Tilt speed mode	step
					60 - 69	Pan/Tilt time mode	step
					70 - 79	Blackout while pan/tilt moving	step
					80 - 89	Disabled blackout while pan/tilt moving	step
					90 - 99	Blackout while colour wheels moving	step
					100 - 109	Disabled blackout while colour wheels moving	step
					110 - 129	Reserved <i>To activate following functions, stop in DMX value for at least 3 s.</i>	step
					130 - 139	Lamp On,reset(total reset except pan/tilt reset)	step
					140 - 149	Pan/Tilt reset	step
					150 - 159	Colour system reset	step
					160 - 169	Zoom/Fresnel reset	step
					170 - 179	Dimmer/Strobe reset	step
					180 - 199	Reserved	step
200 - 209	Total reset	step					
210 - 229	Reserved	step					
230 - 239	Lamp Off	step					
240 - 255	Reserved	step					

**Notes:** \* Range 0-255 DMX at max.speed (0 DMX):

pan=4.5 s

tilt=2.6 s

\*\* Range 0-255 DMX at min. speed (255 DMX):

pan=37min.10 s

tilt=19 min.34 s

\*\*\* Short times are not used for long tracks (e.g. 0.5s for track 0-255 DMX). Times are restricted by mechanical parameters of the fixture.

\*\*\*\* The switch-functions have priority to the equivalent functions in menu „Personality” but the setting by DMX is not saved to the memory (after switching the fixture on,the setting from menu „Personality” is loaded and after that can be changed with DMX value on the channel 6).

### DMX protocol

50 - 59 Pan/Tilt speed mode

60 - 69 Pan/Tilt time mode

70 - 79 Blackout while pan/tilt moving

80 - 89 Disabled blackout while pan/tilt moving

90 - 99 Blackout while colour wheels moving

100 - 109 Disabled blackout while colour wheel moving

### menu „Personality”

Pan/Tilt mode--->Speed Mode

Pan/Tilt mode--->Time Mode

Active blackout While-->Pan/Tilt Moving-->On

Active blackout While-->Pan/Tilt Moving-->Off

Active blackout While-->Colour Wheels Moving-->On

Active blackout While-->Colour Wheels Moving-->Off

Mode/Channel					Value	Function	Type of control
1	2	3	4	5			
		7	7		0 - 9 10 - 31 32 - 63 64 - 95 96 - 127 128 - 159 160 - 191 192 - 223 224 - 255	<b>Pan/Tilt macro selection</b> Disabled pan/tilt macro Reserved Figure of circle (from small to large) Figure of horizontal eight (from small to large) Figure of vertical eight (from small to large) Figure of rectangle (from small to large) Figure of triangle (from small to large) Figure of star (from small to large) Figure of cross (from small to large)	step step proportional proportional proportional proportional proportional proportional
		8	8		0 1 - 127 128 - 129 130 - 255	<b>Pan/Tilt macro speed</b> No macro generation Macro generation from fast to slow-forwards No macro generation Macro generation from slow to fast-backwards	step proportional step proportional
7	7	9	9	7	0 18 37 55 73 91 110 128 - 129 130 - 139 140 - 149 150 - 159 160 - 169 170 - 179 180 - 189 190 - 215 216 - 217 218 - 243 244 - 249 250 - 255	<b>Colour wheel 1</b> Open/white Deep red Deep blue Green Orange 6000 K temperature filter UV filter White Deep red Deep blue Green Orange 6000 K temperature filter UV filter Forwards rainbow effect from fast to slow No rotation Backwards rainbow effect from slow to fast Random colour selection by audio control (Set microphone sensitivity in menu „Personality“) Auto random colour selection from fast to slow	proportional proportional proportional proportional proportional proportional proportional step step step step step step proportional step proportional step proportional
	8		10		0 - 255	<b>Colour wheel 1- fine positioning</b> Fine positioning	proportional
8	9	10	11	8	0 18 37 55 73 91 110 128 - 129 130 - 139 140 - 149 150 - 159 160 - 169 170 - 179 180 - 189 190 - 215 216 - 217 218 - 243 244 - 249 250 - 255	<b>Colour wheel 2</b> Open/white Red ring Blue dot Yellow ring Blue/red Green/orange Yellow/blue/orange/magenta White Red ring Blue dot Yellow ring Blue/red Green/orange Yellow/blue/orange/magenta Forwards rainbow effect from fast to slow No rotation Backwards rainbow effect from slow to fast Random colour selection by audio control (Set microphone sensitivity in menu „Personality“) Auto random colour selection from fast to slow	proportional proportional proportional proportional proportional proportional proportional proportional step step step step step step proportional step proportional step proportional
	10		12		0 - 255	<b>Colour wheel 2- fine positioning</b> Fine positioning	proportional
9	11	11	13	3	0 - 255	<b>Cyan</b> Cyan (0-white, 255-full cyan)	proportional
10	12	12	14	4	0 - 255	<b>Magenta</b> Magenta (0-white, 255-full magenta)	proportional



Mode/Channel					Value	Function	Type of control
1	2	3	4	5			
11	13	13	15	5	0 - 255	<b>Yellow</b> Yellow (0-white, 255-full yellow)	proportional
12	14	14	16	6	0 - 255	<b>Conversion temperature filter 3200K</b> (0-5600K, 255-3200K)	proportional
	15		17			<b>CMY Colour macros</b>	
					0 - 3	No function	step
					4 - 7	Macro 1	step
					8 - 11	Macro 2	step
					12 - 15	Macro 3	step
					16 - 19	Macro 4	step
					20 - 23	Macro 5	step
					24 - 27	Macro 6	step
					28 - 31	Macro 7	step
					32 - 35	Macro 8	step
					36 - 39	Macro 9	step
					40 - 43	Macro 10	step
					44 - 47	Macro 11	step
					48 - 51	Macro 12	step
					52 - 55	Macro 13	step
					56 - 59	Macro 14	step
					60 - 63	Macro 15	step
					64 - 67	Macro 16	step
					68 - 71	Macro 17	step
					72 - 75	Macro 18	step
					76 - 79	Macro 19	step
					80 - 83	Macro 20	step
					84 - 87	Macro 21	step
					88 - 91	Macro 22	step
					92 - 95	Macro 23	step
					96 - 99	Macro 24	step
					100 - 103	Macro 25	step
					104 - 107	Macro 26	step
					108 - 111	Macro 27	step
					112 - 115	Macro 28	step
					116 - 119	Macro 29	step
					120 - 123	Macro 30	step
					124 - 127	Macro 31	step
					128 - 131	Macro 32	step
					132 - 135	Macro 33	step
					136 - 139	Macro 34	step
					140 - 143	Macro 35	step
					144 - 147	Macro 36	step
					148 - 151	Macro 37	step
					152 - 155	Macro 38	step
					156 - 159	Macro 39	step
					160 - 163	Macro 40	step
					164 - 167	Macro 41	step
					168 - 171	Macro 42	step
					172 - 175	Macro 43	step
					176 - 179	Macro 44	step
					180 - 183	Macro 45	step
					184 - 187	Macro 46	step
					188 - 191	Macro 47	step
					192 - 195	Macro 48	step
					196 - 199	Macro 49	step
					200 - 203	Macro 50	step
					204 - 207	Macro 51	step
					208 - 211	Macro 52	step
					212 - 215	Macro 53	step
					216 - 219	Macro 54	step
					220 - 223	Macro 55	step
					224 - 227	Macro 56	step
					228 - 231	Macro 57	step
					232 - 235	Macro 58	step
					236 - 239	Macro 59	step

Mode/Channel					Value	Function	Type of control
1	2	3	4	5			
	15		17		240 - 243 244 - 247 248 - 251 252 - 255	Macro 60 Macro 61 Macro 62 Macro 63	step step step step
13	16	15	18		0 - 255	<b>Effect speed</b> From max. speed to min.speed *****	proportional
	17		19		0 - 31 32 - 63 64 - 95 96 - 255	<b>Effect speed assigning</b> Dimmer + CMY filters + correction filter Dimmer CMY filters + correction filter No function	step step step step
		16	20	10	0 - 255	<b>Barn door 1-Upper</b> From open to close	proportional
		17	21	11	0 - 255	<b>Barn door 2-Lower</b> From open to close	proportional
		18	22	12	0 - 255	<b>Barn door 3-Left</b> From open to close	proportional
		19	23	13	0 - 255	<b>Barn door 4-Right</b> From open to close	proportional
		20	24	14	0 - 255	<b>Barn doors rotation</b> From right to left	proportional
14	18	21	25		0-85 86 87-171 172-213 214-255	<b>Fresnels opening</b> <i>LightMax mode provides a high intensity spot (85DMX)</i> Internal Fresnels opening(from closed to open-LightMax mode) Left Fresnel closed,right Fresnel open Left Fresnel opening,right Fresnel closing Both Fresnels ramping (parallel) from slow to fast Both Fresnels ramping (alternately) from fast to slow	proportional step proportional proportional proportional
15	19	22	26	9	0-255	<b>Zoom</b> Zoom from min. to max.	proportional
	20		27		0-255	<b>Zoom fine</b> Fine zoom positioning.	proportional
16	21	23	28	1	0 - 31 32 - 63 64 - 95 96 - 127 128 - 143 144 - 159 160 - 191  192 - 223 224 - 255	<b>Shutter, strobe</b> Shutter closed, Lamp power reduced after 10 s to 700W Shutter open,Full lamp power Strobe-effect from slow to fast (max.15 flashes/s) Shutter open,Lamp power reduced to 700W Opening pulse in sequences from slow to fast Closing pulse in sequences from fast to slow Shutter open,Electronic strobing "ZAP" from slow to fast (from 7 to 33 flashes/s) Random strobe-effect from slow to fast Shutter open,Full lamp power	step step proportional step proportional proportional proportional  proportional step
17	22	24	29	2	0-255	<b>Dimmer intensity</b> Dimmer intensity from 0% to 100% (In range 0-3 DMX, lamp power reduced to 700 W)	proportional
	23		30		0-255	<b>Dimmer intensity fine</b> Fine dimming	proportional
				15		<b>No function</b>	

\*\*\*\*\* Range 0-255 DMX at min. speed (0 DMX): Cyan (magenta/yellow,cor. filter) = 1min 10 s

## 7. Controller mode

The fixtures are individually addressed on a data link and connected to the controller. The fixtures respond to the DMX signal from the controller.

### 7.1 DMX addressing

There are 512 available channels on DMX link. Every fixture on DMX link must have a DMX start address, which is defined as the first channel from which the fixture will respond to the controller.

If you set, for example, for the ColorWash 1200E AT the start address to channel 25, the ColorWash 1200E AT will use the channels 25 to 48 for control (if Mode 3 is selected from „DMX Preseting” menu).

Please, be sure that you don't have any overlapping channels in order to control each ColorWash 1200E AT correctly and independently from any other fixture on the DMX data link.

If two, three or more ColorWash 1200E AT are addressed similarly, they will work similarly.

#### Controlling:

After having addressed all ColorWash 1200E AT, you may now start operating these via your lighting controller.

**Note:** After switching on, the ColorWash 1200E AT will automatically detect whether DMX 512 data is received or not. If there is no data received at the DMX-input, the display will start to flash with actually address.

This situation can occur if:

- the 3(or 5) pin XLR plug (cable with DMX signal from the controller) is not connected with the input of the ColorWash 1200E AT
- the controller is switched off or defective, the cable or connector is defective or the signal wires are swap in the input connector.

### 7.2 Remotely controllable functions

#### Lamp

The ColorWash 1200E AT is to be operated with a Philips MSR 1200E SA lamp.

A relay inside of the ColorWash 1200E AT allows you to switch on and off the lamp via the control panel or via your DMX-controller without affecting the rest of the lighting.

**Note:** It is also important to note, that the discharge lamp is cold restrike types, that means, that they have to be cold before re-striking. For this reason, you have to wait at least 5 minutes after having switched off the lamp before you can switch it back on again. If you try to switch On the lamp within 5 minutes after having switched it Off, the ColorWash 1200E AT will store this information and automatically ignite the lamp when the 5 minutes period has expired.

#### CMY-colours mixing system

The CMY color mixing system is based on graduated cyan, magenta, and yellow color filters. A continuous range of colors may be achieved by varying the amount of each filter from 0 to 100%.

Colour temperature correction filtre lowers the colour temperature from 5600K to 3200 K.

#### Colour wheel 1

The ColorWash 1200E AT features a colour wheel 1 with 4 colour positions, UV filter and 6000 K temp. filter and the hole (open). It is also possible to rotate the colour wheel continuously at different speeds, the so-called „Rainbow effect“ is created. Auto random colour selection, random colour selection by audio control is possible.

#### Colour wheel 2

The ColorWash 1200E AT included a colour wheel 2 with 6 colour positions and the hole (open). It is also possible to rotate the colour wheel continuously at different speeds, the so-called „Rainbow effect“ is created. Auto random colour selection, random colour selection by audio control is possible.

#### Zoom

Motorized zoom, zoom range depends on the front lens. Open internal Fresnel lens (LightMax mode) provides a high intensity spot (channel “Fresnel opening“ is set at 85 DMX).

Fresnel lens	Beam angle
LightMax mode	10°
Minimum zoom	13°
Maximum zoom	44°

Wide-angle lens	Beam angle
LightMax mode	68°
Minimum zoom	75°
Maximum zoom	87°

#### Dimmer/Shutter/Strobe

Smooth 0 - 100 % dimming is provided by the combined mechanical dimmer/shutter unit. This unit may also be used for strobe effect.

# 8. Control menu map

Note: Default settings = **Bold print**

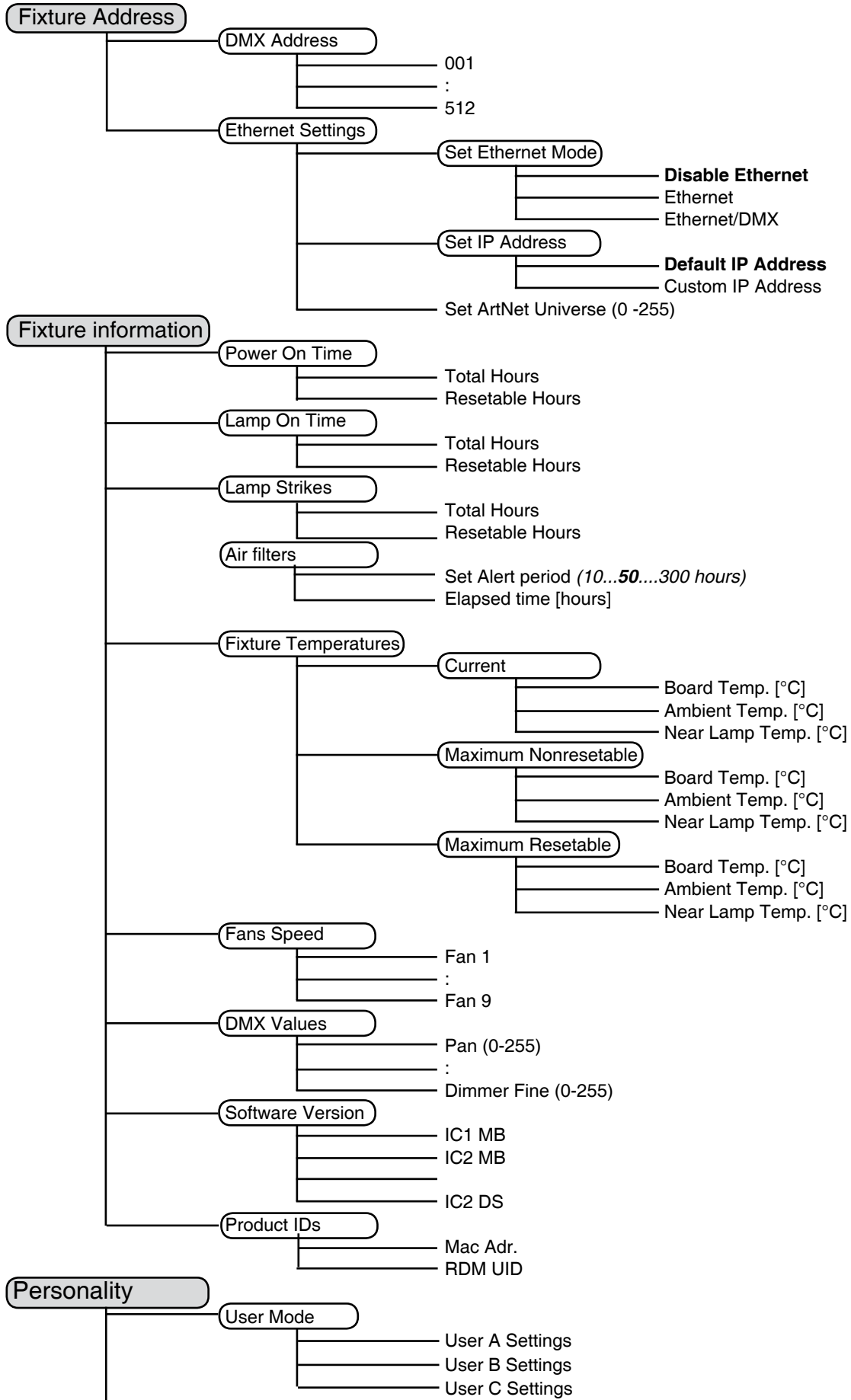

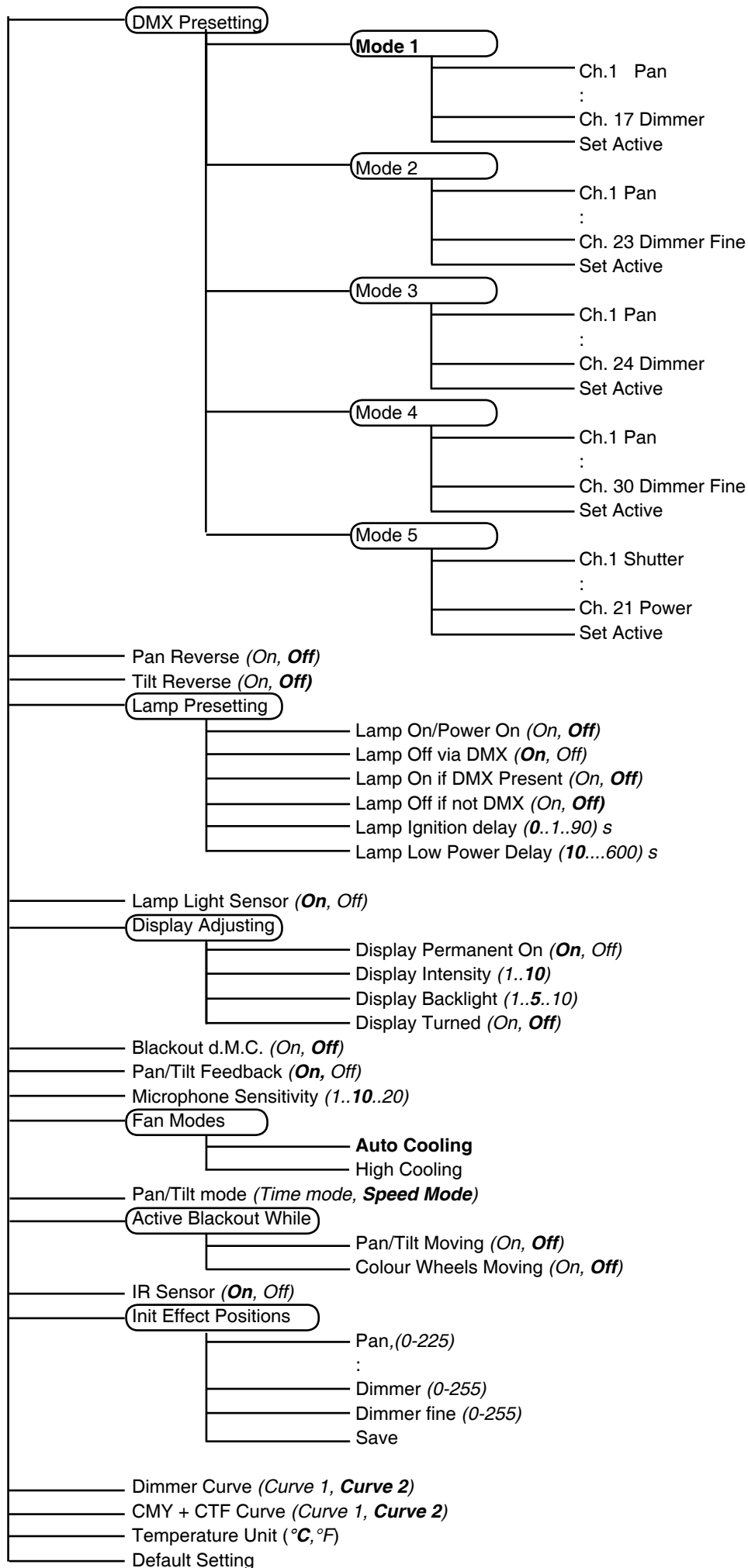

Lamp On/Off (*On, Off*)

Test sequences

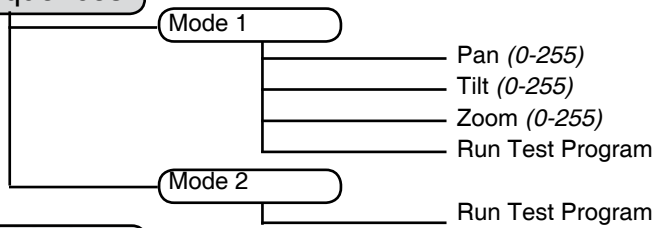

Manual Mode

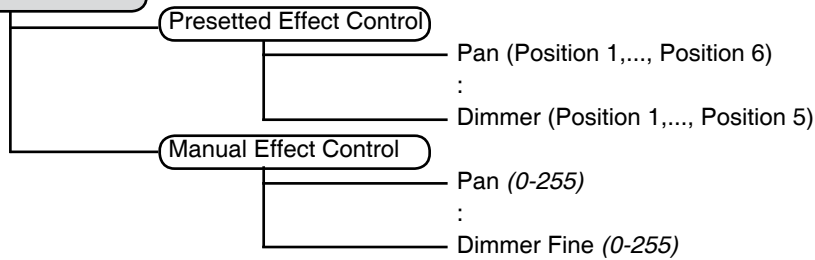

Stand- alone setting

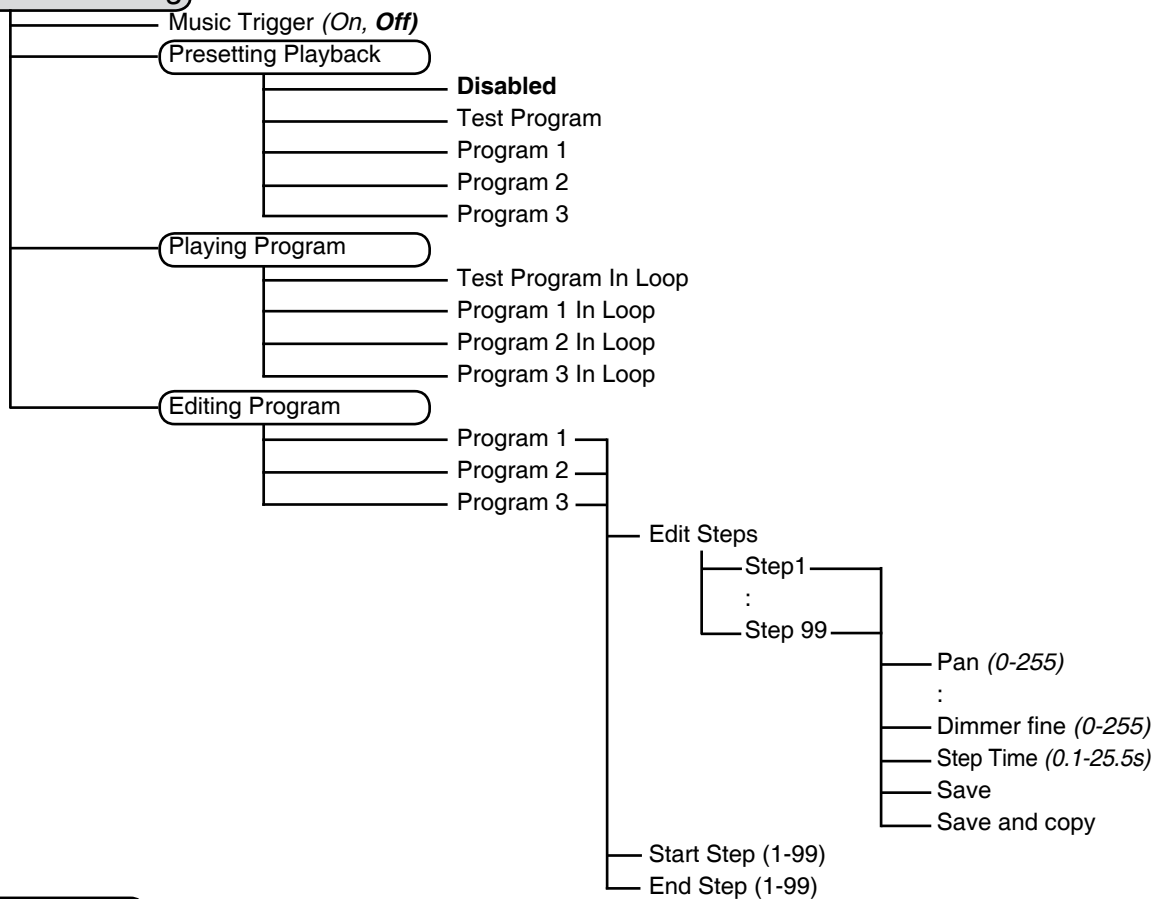

Reset functions

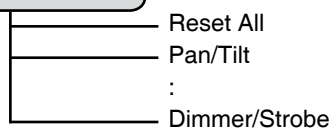

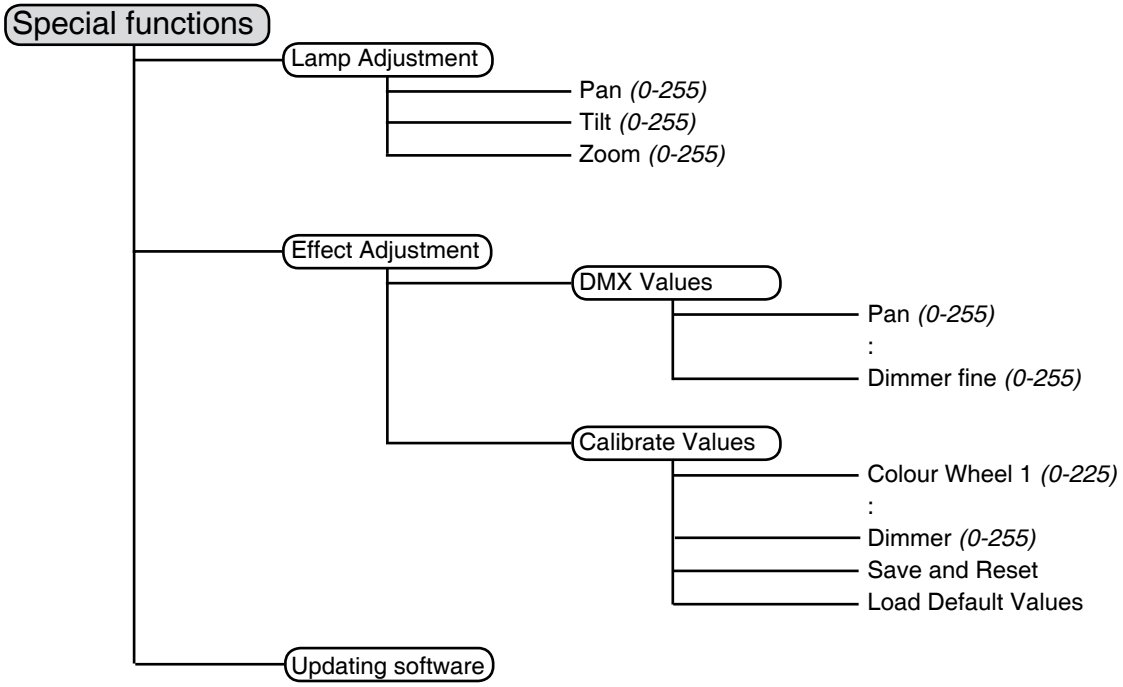

## 9. Control menu

The control panel situated on the front panel of the base offers several features. You can simply set the DMX address, read the number of the lamp or unit hours, switch On and Off the lamp, run test, make a reset and also use many functions for setting fixture behaviour.

### Control elements on the control board:

[RNS] encoder wheel-moves between menu items on the the same level, scrolls between values.

[ESC] button-leaves menu without saving changes

[ENTER] button-enters menu, confirms adjusted values and leaves menu

**After switching the fixture on,  
the display shows the initial screen:**



**Press [ENTER],  
the display shows current address:**



The main menu of the control panel is accessed by pressing [ENTER] button. To browse through the menu, rotate [RNS] wheel. To select a function or submenu, press [ENTER] button. Presetted options are displayed negative.

### 9.1 Fixture Address

Use this menu to set the DMX address.

**DMX Address** - Select this submenu to set DMX start address.

**Ethernet Settings** - Select this submenu to set the fixture for Ethernet operating.

**Set Ethernet Mode** - Select this submenu to select Ethernet operating mode:

**Disable Ethernet** - disables network operating.

**Ethernet** - Data are received to the Ethernet input of the fixture - every fixture from fixture chain has to be connected to the network.

**Ethernet/DMX** - Data go from Ethernet input „through” the fixture to the DMX output of the fixture- it is possible to connect the next fixture to DMX output and to make a DMX chain.

**Set IP Address** - Select this submenu to set IP address. IP address is the Internet protocol address.

The IP uniquely identifies any node (fixture) on a network. There can't be 2 fixtures with the same IP address on the network!

**Default IP Address** - Presetted IP address, you can edit only first number of IP address (2 or 10) e.g. **002.019.052.086**.

**Custom IP Address** - The option enables edit all numbers of IP address e.g. **002.019.052.086**.

To set the custom IP address:

1. Select „Custom IP Address” and press [ENTER].
  2. Use RNS wheel to set the first number of IP address
  3. Press [ENTER] to move on the second number of IP address
  4. Repeat steps 2 and 3 for the third and the fourth number of IP address.
- If you want to return back on the previously edited number, press [ESC].

**Set ArtNet Universe** - Select this submenu to set a Universe (0-255). The Universe is a single DMX 512 frame of 512 channels.

### 9.2 Fixture informations

Use this menu to read an useful information about the fixture.

**Power On Time** - Select this submenu to read the number of operation hours.

**Total Hours** - The function shows the total number of the operation hours since the ColorWash 1200E AT has been fabricated.

**Resetable Hours** - The function shows the number of the operation hours that the ColorWash 1200E AT has been powered on since the counter was last reset. In order to reset this counter to 0, press [ENTER] twice.

**Lamp On Time** - Select this submenu to read the number of the operation hours with the lamp on.

**Total Hours** - The function shows the total number of the operation hours with the lamp on since the ColorWash 1200E AT has been fabricated.

**Resetable Hours** - The function shows the number of the operation hours with the lamp on that the ColorWash 1200E AT has been powered on since the counter was last reset. In order to reset this counter to 0, press [ENTER] twice.

**Lamp Strikes** - Select this submenu to read the total number of the lamp strikes.

**Total Hours** - The function shows the total number of the lamp strikes since the ColorWash 1200E AT has been fabricated.

**Resetable Hours** - The function shows the number of the lamp strikes since the counter was last reset. In order to reset this counter to 0, press [ENTER] twice.



**Air Filters** --- Regular cleaning of the air filters is very important for the fixture's life and performance. Buildup of dust, dirt and fog fluid residues reduces the fixture's light output and cooling ability. The two items of this menu help you to keep cleaning period of the air filters.

**Set alert period** - Cleaning schedule for the fixture depends on the operating environment. It is therefore impossible to specify accurate cleaning interval. This function allows you to change the cleaning interval of the air filters. This "alert" value is 50 hours and it is set as default. Inspect the fixture within its 50 hours of operation to see whether cleaning is necessary. If cleaning is required, clean all air filters and change the value in this menu on acceptable level. Min. level of alert period is 10 hours, max. is 300 hours.

**Elapsed Time** - The option allows you to read the time which remains to cleaning air filters. The time period is set in the menu mentioned above. Expired time period is signaled by a negative mark at the time value and a warning icon (triangle) on the display with the following message: "Clean Air Filters"  
Clean the filters and reset this menu item (by pressing "Enter" button twice while this menu is highlighted) to start the new time countdown.

**Fixture Temperatures** - Select this submenu to read the temperatures of the fixture:

**Current** - Select this function to read the current temperatures of the fixture inside (Board Temp., Ambient Temp., Near Lamp Temp.)

**Maximum nonresetable** - The function shows the max. temperatures of the fixture inside (Board Temp., Ambient Temp., Near Lamp Temp.) since the ColorWash 1200E AT has been fabricated.

**Maximum resetable** - The function shows the maximum temperatures of the fixture inside (Board Temp., Ambient Temp., Near Lamp Temp.) since the respective counter was last reset. In order to reset desired counter to 0, press [ENTER] twice.

Measurement points:

**Board Temp.** - temperature on the main board in the fixture base.

**Ambient Temp.** - temperature of the air which is sucked to the fixture base. This temperature can be different from the real ambient temperature due to e.g. suction of the hot air from the fixture head to the base if the fixture is hanging at the ceiling. Please note that the ambient temperature should not exceed 40°C.

**Near Lamp Temp.** - temperature in the lamp chamber.

**Fans Speed** - Select this function to read the actual speed of the fans (revolutions per minute):

**Fan 1** - The fan cools the lamp peak

**Fan 2** - The fan cools the lamp base

**Fan 3** - The fan on the rear left side of the head

**Fan 4** - The fan on the rear right side of the head

**Fan 5** - The left fan at the CMY module

**Fan 6** - The right fan at the CMY module

**Fan 7** - The Fan inside the head

**Fan 8** - The fan on the front left side of the head

**Fan 9** - The fan on the front right side of the head

**Location of the fans:**  
(Top view)

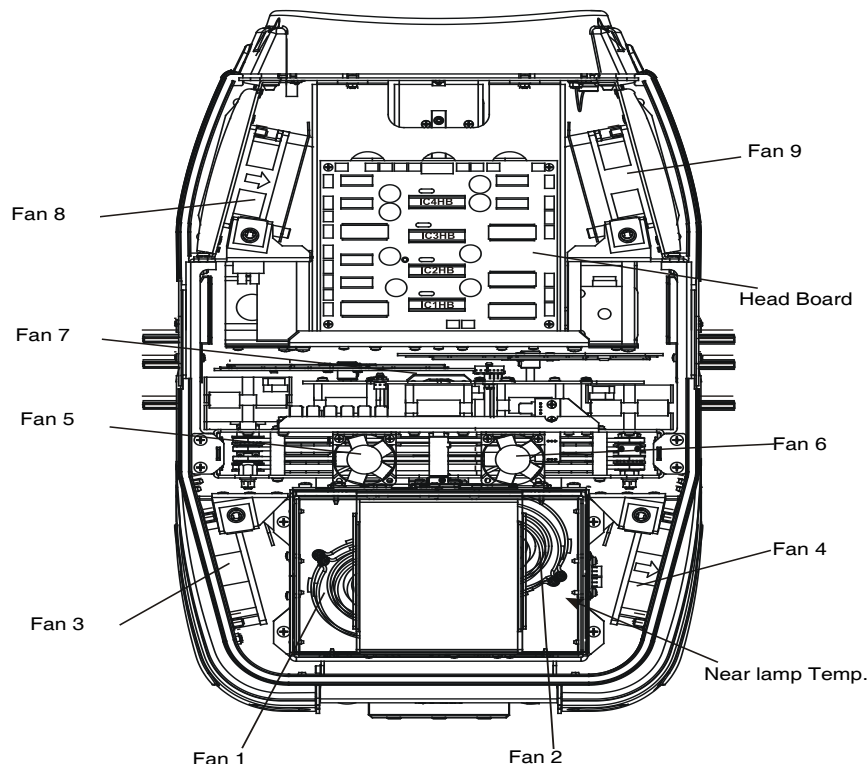

**DMX Values** - Select this function to read DMX values of each channel received by the fixture.

**Product IDs** - Select this function to read the MAC address of the fixture or the RDM UID number.

**Software Version** - Select this function to read the software version of the fixture modules:

- IC1 MB** - Main processor on the main board in the fixture base
- IC2 MB** - Tilt processor on the main board in the fixture base
- IC3 MB** - Pan processor on the main board in the fixture base
- IC4 MB** - EEprom on the main board in the fixture base
- IC1 HB** - CMY and conversion filter 3200K processor on the board in the fixture head
- IC2 HB** - Dimmer and cyan processor on the board in the fixture head
- IC3 HB** - Fresnel 1/2 and zoom processor on the board in the fixture head
- IC4 HB** - Colour wheel 1/colour wheel 2 processor on the board in the fixture head
- IC1 DS** - Display processor on the display module in the fixture base
- IC2 DS** - Memory on the display module in the fixture base

### Location of the fans, processors and temperature measuring points:

Base (Top view):

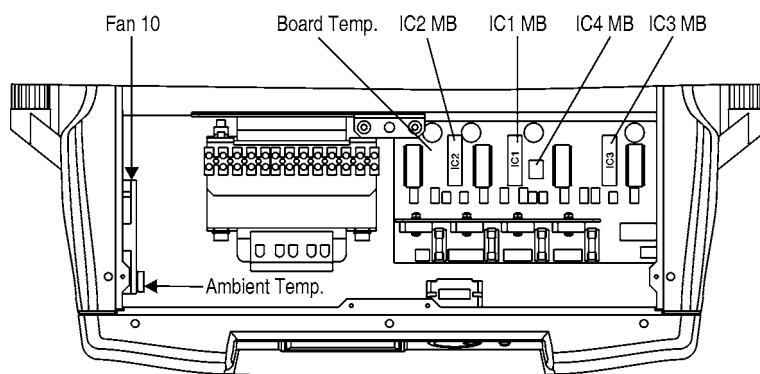

Display module (Rear view)

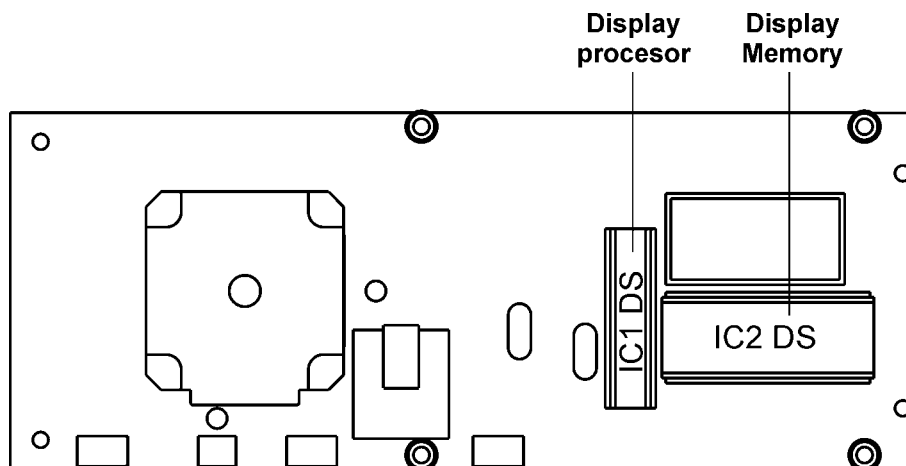

## 9.3 Personality

Use this menu to modify ColorWash 1200E AT operating behavior.

**User mode** - ColorWash 1200E AT allows you to recall up to 3 user settings. After switching the fixture on for the first time, the **User A settings** are active. All changes made in „Personality” menu, „Fixture Address” menu and Music Trigger and Presetting Playback functions from „Stand-alone setting” menu are saved to the **User A settings**. If you now set the **User B settings** active, from this moment these changes are saved to the **User B settings**. After switching the fixture off and on, the User B setting is active. In this way you may use 3 fixture operating behaviour.

**User A Settings** - The function recall the user A settings.

**User B Settings** - The function recall the user B settings.

**User C Settings** - The function recall the user C settings.

**Pan Reverse** - Select this function to invert the pan movement.

**Tilt Reverse** - Select this function to invert the tilt movement.

**DMX Presetting** - Select this function to set desired effects assigning to the channels. You can choose 5 effects orders

(Mode 1-17 channels, Mode 2-23 channels, Mode 3-24 channels, Mode 4-30 channels, Mode 5-21 channels). Please refer to the chapter "DMX protocol" for detail description. Mode 1 is default channels setting:  
Please refer to the chapter "DMX - protocol" for detail description.

**Lamp Presetting** - Select this menu to change the lamp „behaviour“.

**Lamp On/Power On** - Select this function to turn the lamp on automatically after switching the fixture on.

**Lamp Off via DMX** - Select this function to switch off the lamp via DMX.

**Lamp On if DMX Present** - This function allows you to strike the lamp automatically after 26 seconds if DMX signal is present on the data link. If the ignition is unsuccessful (e.g. lamp is too hot), the fixture will try to ignite the lamp after next 26 s. This process will repeat until the lamp lights.

**Lamp Off if not DMX** - This function allows you to switch Off the lamp automatically after 2 minutes if DMX signal is missing on the data link.

**Lamp Ignition Delay** - This function allows you to set the time delay (0-90s) before the lamp will be ignited. This setting will not affect starting the lamp direct from the control panel (menu "Lamp On/Off").

**Lamp Low Power Delay** - This function enables set the time period after that the lamp power will be reduced if the shutter/dimmer is closed. The delay time can be set up to 600seconds. Default setting is 10s.

**Lamp Light Sensor** - Select this function to switch the lamp light sensor on or off. The option „On“ is for the standard operation.

Important: The option „Off“ is for „emergency operation“ only if the lamp light sensor is defective and you will wait for a service intervention! If the lamp light sensor is switched off and at switching the lamp on the electronics will still try to ignite the lamp until it shines (even when the lamp is damaged or absent), on this account some electronics parts could be damaged!

**Display Adjusting** - This function allows you to change the display settings.

**Display Permanent On** - This function allows you to keep the display on or to turn off automatically 2 minutes after last pressing any button (or a wheel movement) on the control panel.

**Display Intensity** - Select this function to adjust the display intensity (1-min., 10-max.).

**Display Backlight** - Select this function to adjust the display backlight (1-min., 10-max.).

**Display Turned** - Select this function to turn the display by 180°.

**Blackout d.M.C.** - Select this function to enable the blackout during the head movement correction (if the moving head lost its right pan/tilt position for a short moment).

**Pan/Tilt Feedback** - This function allows to return the moving head to the required pan/tilt position after changing the position by external force (e.g. by stroke).

**Be careful, the Pan/Tilt Feedback OFF is not the standard operation and the head of the fixture can be damaged!**

**Note:** If the feedback was switched off, the pan/tilt-position is changed by an external force and the feedback is switched on again, the moving head might not to be synchronized with the DMX signal. You have to make a reset in order to synchronize the moving head with the DMX signal.

**Microphone Sensitivity** - Select this function to adjust the microphone sensitivity from 1 (maximum) to 20 (minimum). If the sensitivity is correctly adjusted, the mark  will appear (blinking in the bass beat.)

**Fan Modes** - By using this function you can choose 2 types of the fan speed operating modes.

**Auto Cooling** - The fans automatically raise their speed in order to control inside temperature of the lighting, if the temperature inside increases about certain level (the low fan speed reduces the cooling of the lighting). This cycle can repeat several times until the temperature inside is on a suitable level.

**High Cooling** - The cooling fans work on max. speed (max. cooling). This mode we recommend for high ambient temperature (30 °C and more).

**Pan/Tilt mode** - Use this menu to set the character of the pan/tilt movement.

**Time mode** - Pan and tilt will move with different speeds and they will come at the same time to end point (pan and tilt sets its optimal speed).

**Speed Mode** - Pan and tilt will move with the same speed as adjusted with the channel 5 (Pan/Tilt speed).  
E.g. pan will come to the end point and wait for tilt, which has longer track.

**Active Blackout while:** - Use this function if you wish to close the light output during effect changes.

**Pan/Tilt Moving** - This function closes the light output during pan/tilt changes.

**Colour Wheels Moving** - This function closes the light output during colour changes.

**IR Sensor** - Select this function to switch on/off infra-red remote control.

**Init Effect Positions** - Select this function to set all effects to the desired positions. After switching the fixture on (if DMX is not connected), all effects will move to this init positions.

**Dimmer Curve** - Select desired dimmer running.

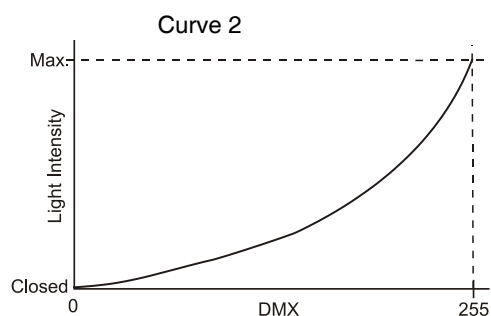
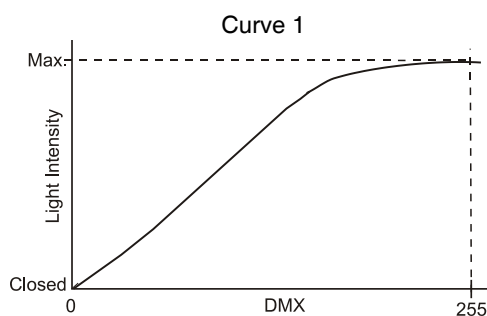

**CMY + CTF Curve** - Select desired CMY filters + conversion temperature filter running.

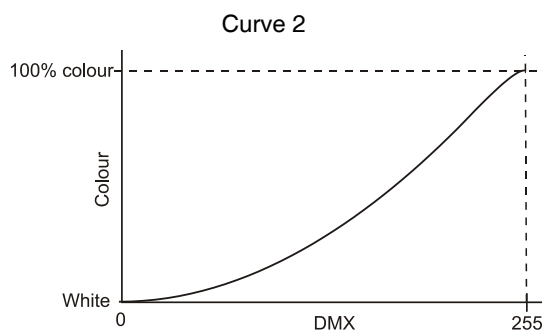
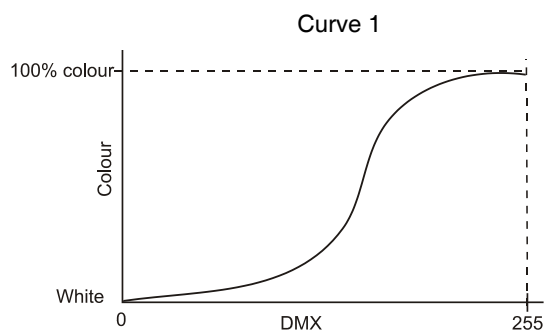

**Temperature Unit** --- Select this menu in order to display fixture temperatures in °C or °F.

**Default Settings** - Select this option to reset all fixture personalities to the default values.

## 9.4 Lamp On/Off

Use this option in order to switch on/off the lamp. It is also important to note, that the lamp is cold restrike type, that means, that it has to be cold before striking.

## 9.5 Test sequences

Use this menu to to run a special demo-test sequences without an external controller, which will show you some possibilities of using ColorWash 1200E AT.

Mode 1 - This mode is suitable for projections on the wall, ceiling or ground without any head movement.

Mode 2 - This mode uses all ColorWash 1200E AT functions including pan/tilt movement and therefore is good for a complete introduction of the fixture.

## 9.6 Manual mode

**Presettled Effects** - Select this menu to call up presettled positions of channel effects.

**Manual Effect control** - Select this menu to control channels by control elements on the control board.

## 9.7 Stand-alone setting

Use this menu to set options for stand-alone mode as a selection of the playing program, programming and modifying current programs.

**Music Trigger** - Select this function to enable the sound control of the running programs via the built-in microphone.

**Presetting Playback** - This function allows you to select the program which will be played in the stand-alone mode after switching the fixture on. Selected program will be played continuously in a loop.

**Disabled** - The option disables „Presetting playback” function.

**Test Program** - The option will start built-in test program.

**Program 1** - The option will start created program No.1

**Program 2** - The option will start created program No. 2

**Program 3** - The option will start created program No. 3

**Note:** If the fixture operates in the controller mode (DMX controller is connected) and any program from this menu is selected, in this case the fixture will not respond to the DMX controller after switching on and will play selected program.

**Playing program** - Select this menu to run a built-in program or the 3 freely-programmable programs in a loop.

**Test Program In Loop** - The option starts built-in test program.

**Program 1 In Loop** - The option starts created program No. 1

**Program 2 In Loop** - The option starts created program No. 2

### Program 3 In Loop - The option starts created program No. 3

Select the program you wish and press [ENTER]. The selected program starts running. By Pressing [ENTER] again is possible to pause the program running.

**Editing Program** - Select this menu to edit or create the program. The ColorWash 1200E AT has one built-in program and the 3 free programs, each up to 99 steps. Each program step has a step time. Step time-the time, during which effects last in the current step.

#### Procedure:

1. Select the program you want to edit („Program 1” - „Program 3”) and press [ENTER].
2. Select „Edit Steps” menu and press [ENTER].
3. Select the desired program step („Step 01” - „Step 99”) and press [ENTER].
4. Select the desired item and press [ENTER]. Now you can edit DMX value for selected item:

"Pan"- a coarse pan, value 0-255

"Pan Fine" - a fine pan, value 0-255

"Tilt" - a coarse tilt, value 0-255

"Tilt Fine" - a fine tilt, value 0-255

"Pan/Tilt Speed" - a speed of pan/tilt movement, value 0-255

"Spec. Func." - a special functions, lamp on/off, reset, value 0-255

"Pan/Tilt Macro" - a pan/tilt macro, value 0-255

"P./T.Macro Speed" - a pan/tilt macro speed, value 0-255

"Colour Wheel 1" - a colour wheel 1, value 0-255

"Colour 1 Fine" - a colour wheel 1-fine positioning, value 0-255

"Colour Wheel 2" - a colour wheel 2, value 0-255

"Colour 2 Fine" - a colour wheel 2-fine positioning, value 0-255

"Cyan" - a cyan, value 0-255

"Magenta" - a magenta, value 0-255

"Yellow" - an yellow, value 0-255

"Conversion Filter" - a conversion temperature filter, value 0-255

"CMY Colour Macro" - a CMYcolour macro, value 0-255

"Effect Speed" - a effect speed, value 0-255

"Effect Speed. Assig." - a effect speed assigning,value 0-255

"Fresnel opening" - a fresnel opening,value 0-255

"Zoom" - a coarse zoom,value 0-255

"Zoom fine" - a fine zoom movement,value 0-255

"Shutter/Strobe" - a shutter and strobe,value 0-255

"Dimmer" - a dimmer intensity-coarse, value 0-255

"Dimmer Fine" - a dimmer intensity-fine, value 0-255

5. Select „Save” or „Save and Copy” and press [Enter] to confirm adjusted values:

"Save" - saving the current prog. step

"Save and Copy" - saving and copying the current prog. step to the next prog. step.

6. Go on next prog. step and repeat this procedure (steps 4 and 5).

After creation the program, you can simply reduced its length (by changing the start/end steps) using the „Start Step” and „End Step” menu.

## 9.8 Reset functions

The ColorWash 1200E AT can be reset totally or by function modules. Select relevant function to run a reset:

**Reset All** - This function enables the fixture to index all effects and return to their standard positions.

**Pan/Tilt** - This function resets pan and tilt.

**Colour System** - This function resets colour wheels and CMY/conversion filter module.

**Dimmer/Strobe** - This function resets dimmer/strobe module.

**/Zoom/Fresnel** - This function resets zoom and inside Fresnel lens .

## 9.9 Special functions

Use this menu for special services like adjusting lamp or adjusting effects.

**Lamp Adjustment** - This function can be used when you make the fine adjustment of the lamp. If you select this function, all effects will be canceled, shutter will be opened and the dimmer intensity will be set onto 100%. By using the options „**PAn, Tilt, Zoom**” you can aim the light at a flat surface (wall) and perform the fine lamp adjustment.

**Effect Adjustment** - By this function you can calibrate and adjust the effects to their standard/right positions. Disconnect the DMX controller from the fixture and select „**DMX Values**” menu. The display shows step by step effects by which you can adjust the fixture to the required position before the function calibration. When the positioning is finished, select „**Calibrate Values**” and press [ENTER]:

### 1. Calibration via the control board

Select desired effect, press [ENTER] and adjust its right value (0 - 255). This can be repeated for each calibrated effect if it is required. When the calibration is finished, it is necessary to use the „**Save and Reset**” function to write the calibration values to the memory and to make a reset in order to check the newly adjusted positions of the calibrated effects.

### List of the calibrated effects:

Colour Wheel 1	Magenta	Right Fresnel Open.
Colour Wheel 2	Yellow	Left Fresnel Open.
Cyan	Conversion Filter	Zoom
		Dimmer

## 2. Calibration via the DMX controller

Connect the DMX controller to the fixture. Select desired effect and press [ENTER]. Now you can calibrate the selected effect by your controller.

Effect	Mode 1	Mode 2	Mode 3	Mode 4	Mode 5
Colour wheel 1	channel 18	channel 24	channel 25	channel 31	channel 22
Colour wheel 2	channel 19	channel 25	channel 26	channel 32	channel 23
Cyan	channel 20	channel 26	channel 27	channel 33	channel 24
Magenta	channel 21	channel 27	channel 28	channel 34	channel 25
Yellow	channel 22	channel 28	channel 29	channel 35	channel 26
Conversion filter	channel 23	channel 29	channel 30	channel 36	channel 27
Right Fresnel Open.	channel 24	channel 30	channel 31	channel 37	channel 28
Left Fresnel Open.	channel 25	channel 31	channel 32	channel 38	channel 29
Zoom	channel 26	channel 32	channel 33	channel 39	channel 30
Dimmer	channel 27	channel 33	channel 34	channel 40	channel 31

After having calibrated required effects, use the „Save and Reset” function to write the calibration values to the memory and to make a reset in order to check the newly adjusted positions of the calibrated effects.

Item „Load Default Values” enables to load default factory calibration values.

**Updating software** - Using this function you can update software in the fixture via PC and serial link.

The following are required in order to update software:

- PC running Windows 95/98/2000/XP or Linux
- DMX Software Uploader
- Flash cable RS232/DMX (No.13050624)

**Note1:**Software update should execute a qualified person.If you lack qualification, do not attempt the update yourself and ask for help your ROBE distributor.

**Note 2:**DMX address, IP address ,programs 1-3 and all functions in menu Personality will be set to their default values.

### To update software in the fixture:

#### 1.Installation of DMX Software Uploader.

- 1.DMX Software Uploader program is available from the ROBE web site at WWW.robe.cz.
- 2.Make a new directory ( e.g. Robe\_Uploader) on your hard disk and download the software to it.
- 3.Unpack the program from the archive. Program file has name:DSU\_name of corresponding fixture\_SoftwareID.If the Robe fixture is produced in magnetic and electronic ballast version, name of DMX Software Uploader is the same for both versions.  
SoftwareID describes the versions of fixture software included in DMX Software Uploader. Higher number means later software versions.

#### 2.Fixture software updating.

- 1.Determine which of your COM port is available on your PC and connect it with to the DMX input of the fixture using the Flash cable. Do not extend this cable! Disconnect the fixture from the other fixtures in DMX chain! Turn on the computer and the fixture. Make sure that the lamp is switched off.
- 2.Switch the fixture to the update mode by selecting the option Updating Software in menu Special Functions on the fixture control panel.(From this option you cannot return back to the main menu. If you do not want to continue in software update, you have to switch off and on the fixture to leave this option!)
- 3.It is recommended that you exit all programs before running this Software Uploader.
- 4.Start the Software Uploader program. Select desired COM and then click Connect button.  
If the connection is OK, click Start Uploading button to start uploading. It will take several minutes to perform software update. If the option "Incremental Update" isn't checked ,all processors will be updated (including processors with the same software version).  
If you wish to update only later versions of processors, enable the Incremental Update check box.  
Avoid interrupting the process. Update status is being displayed in the list window.  
When the update is finished, the line with the text "The fixture is successfully updated" will appear in this window and the fixture will reset with the new software.

Note: In the case of interruption of the upload process (e.g. power cut), the fixture remains in the update mode and you have to repeat the software update again.

For example: The fixture was switched off before finishing software upload. After switching the fixture on again, the fixture is still in the update mode and the display is dark. Restart the Software Uploader program and repeat software update from your PC.

## 10. Power down mode

This mode omits fixture reset after switching the fixture on and reduces motor powers of the fixture. „Power down mode” is useful in special cases, e.g. if the fixture is in a flight case and you want to set its DMX address without taking it out from the case. To enter „Power down mode”:

Press and hold [ENTER] and at the same time switch on the Power switch. The following message appears:

Really Skip Initial Reset?  
Escape/Enter

Press [ENTER] to activate „Power down mode” without fixture reset. Now you can set features and behaviour of the fixture by using „Fixture Address” menu and „Personality” menu. It is expected, that this mode will be exited by switching the fixture off, but if you want to go directly to „normal operation mode”, execute any fixture reset.

**Note:** All motors in „Power down mode” are deactivated and switching the lamp on from the control panel is blocked.

## 11. RDM

This fixture supports an RDM operation. The RDM (Remote Device Management) is a bi-directional communications protocol for use in DMX512 control systems, it is the new open standard for DMX512 device configuration and status monitoring. The RDM protocol allows data packets to be inserted into a DMX512 data stream without adversely affecting existing non-RDM equipment. By using a special „Start Code,” and by complying with the timing specifications for DMX512, the RDM protocol allows a console or dedicated RDM controller to send commands to and receive messages from specific moving lights.

The ROBE DreamBox with an additional ROBE RDM-network software provides the RDM functionality. The DreamBox supports RDM - new control protocol featuring AutoPatch and Fixture Status Monitoring.

The list of RDM commands for ColorWash 1200E AT is the following:

Parameter ID	Discovery command	SET command	GET command
DISC_UNIQUE_BRANCH	*		
DISC_MUTE	*		
DISC_UN_MUTE	*		
DEVICE_INFO			*
SUPPORTED_PARAMETERS			*
SOFTWARE_VERSION_LABEL			*
DMX_START_ADDRESS		*	*
IDENTIFY_DEVICE		*	*
DEVICE_MODEL_DESCRIPTION			*
MANUFACTURER_LABEL			*
DEVICE_LABEL		*	*
SENSOR_DEFINITION			*
SENSOR_VALUE			*
DISPLAY_INVERT		*	*
DISPLAY_LEVEL		*	*
PAN_INVERT		*	*
TILT_INVERT		*	*
DEVICE_RESET		*	
DMX_PERSONALITY		*	*
DMX_PERSONALITY_DESCRIPTION			*
STATUS_MESSAGES			*
STATUS_ID_DESCRIPTION			*
LAMP_STATE		*	*
LAMP_ON_MODE <sup>1</sup>		*	*
DEVICE_HOURS <sup>2</sup>			*
LAMP_HOURS <sup>2</sup>			*
LAMP_STRIKES <sup>2</sup>			*

<sup>1</sup>...Another options for this command (only for Robe´s fixtures):

value PARAMETER\_DATA=0x84 - lamp OFF by DMX value on DMX channel  
value PARAMETER\_DATA=0x88 - lamp OFF if DMX is not present

<sup>2</sup>...Commands relative resetable values

## 12. Error and information messages

Occured errors during fixture operation are signaled by warning icon on the display:

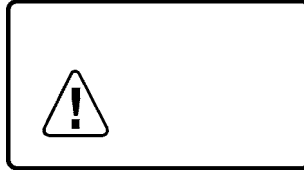

Press [ESC] to see the current error messages. Description of the error messages:

### **Active Lamp Timer**

This message appears if you try to switch on the lamp within 5 minutes after having switched it off (the lamp is too hot). The message will appear on the display if the lamp doesn't ignite within 28 seconds. The ColorWash 1200E AT will store this information and automatically ignite the lamp when the 5 minutes period has expired.

**Caution:** The message is disabled if the lamp light sensor (function "Lamp Sensor" in menu Personality) is switched Off.

### **Starting lamp**

This message appears during igniting the lamp or together with the message "Active Lamp Timer".

### **Lamp Error**

The ignition of the lamp is seven times unsuccessful (the "Active Lamp Timer" message appeared six times before), and the display shows "Lamp Error", meaning that the lamp could be damaged or even missed or there could be a failure on the ignitor or ballast.

Please place or replace the lamp and contact your dealer if the situation was not caused by the lamp.

**Caution:** The message is disabled if the lamp light sensor (function „Lamp Sensor" in menu Personality) is switched off.

### **Overheated ->Lamp Off**

This message informs that the fixture head is overheated and the lamp was switched off by its temperature sensor.

### **Overheated ->Lamp low**

This message informs that the fixture head is overheated and the lamp power was reduced to 700 W. After 10 minutes the lamp power will be switched to the full power.

### **Lamp Sensor Error**

This message informs the lamp light sensor is failed.

**Caution:** The message is disabled if the lamp sensor (function Lamp Sensor in menu Personality) is switched Off.

### **Short Power Error**

This message will appear if the fixture was shortly disconnect from the main.

### **Supply Frequency Error**

This message will appear if the frequency of the main is not standard 50 or 60 Hz. This message can appear as a result of the interference during the lamp starting (if the lamp or igniter is old) or as a result of the interference by neighbouring devices. **In these cases the message does not affect the fixture operating!**

The following error messages are separated into 2 groups:

**xxxx xxxx Error 1** (e.g. Colour Wheel 1 Error 1, Colour Wheel 2 Error 1)

**xxxx xxxx Error 2** (e.g. Colour Wheel 1 Error 2, Colour Wheel 2 Error 2)

There are some possible reasons of faults:

#### **Message**

**xxxx xxxx Error 1**

#### **Characteristic fault**

Magnetic sensor is permanently On (e.g. leading wire is short-circulated, defective stepping motor, defective control circuit on the PCB)

**xxxx xxxx Error 1/xxxx xxxx Error 2**  
(together)

Magnetic sensor is permanently Off (e.g. leading wire is disconnected, defective magnetic sensor, missing magnet), defective stepping motor.

### **Colour Wheel 1 Error 1 (Colour Wheel 1 Error 2)**

The messages will appear after the reset of the colour wheel if this wheel is not located in the default position.

### **Colour Wheel 2 Error 1 (Colour Wheel 2 Error 2)**

The messages will appear after the reset of the colour wheel if this wheel is not located in the default position.

### **Cyan Lamella Error 1 (Cyan Lamella Error 2)**



The messages will appear after the reset of the CMY module if the cyan lamellas are not located in the default positions.

#### **Magenta Lamella Error 1 (Magenta Lamella Error 2)**

The messages will appear after the reset of the CMY module if the magenta lamellas are not located in the default positions.

#### **Yellow Lamella Error 1 (Yellow Lamella Error 2)**

The messages will appear after the reset of the CMY module if the yellow lamellas are not located in the default positions.

#### **CTO Lamella Error 1 (CTO Lamella Error 2)**

The messages will appear after the reset of the CTO module if the CTO lamellas are not located in the default positions.

#### **Zoom Error 1 (Zoom Error 2)**

The messages will appear after the reset of the zoom module if the module is not located in the default position.

#### **Pan Error 1 (Pan Error 2)**

The messages will appear after the reset of the yoke if the yoke is not located in the default position.

#### **Tilt Error 1 (Tilt Error 2)**

The messages will appear after the reset of the head if the head is not located in the default position.

## **13. Technical specifications**

### **Power supply:**

Voltage: ..... 100/120/208/230/250V AC, 50/60Hz ~

Main fuses: Live fuse: ..... T10A@230V

Neutral fuse: .... T10A@230V

Live fuse: ..... T20A@120V

Neutral fuse: .... T20A@120V

Power consumption: ..... 1500 VA (steady state)

### **Lamp:**

Philips MSR 1200 SA, base: GY22, colour temperature: 5600 K, average lamp life: 750 h

### **Optical System:**

- High luminous-efficiency parabolic reflector
- Focus lens and multistep zoom lenses system
- Beam angle: 10°- 87° (depends on the front lens)
- All lenses are anti-reflection coated

### **CMY-colours mixing module**

- Smooth CMY colour mixing system
- Colour temperature correction filter lowers the colour temperature from 5600K to 3200 K
- 63 colour macros

### **Colour wheel 1**

- 4 dichroic filters, UV filter, 6000K temp. filter plus white
- Colour wheel with variable rotation speed in both directions
- All colour-modules are interchangeable
- Random colour selection by audio control
- Auto random colour selection

### **Colour wheel 2**

- 6 colour filters plus white
- Colour wheel with variable rotation speed in both directions
- All colour-modules are interchangeable
- Random colour selection by audio control
- Auto random colour selection

### **Strobe**

- Strobe effect with variable speed (max.15 flashes per second)
- Preprogrammed macros with variable/random pulse effects

### **Dimmer**

- Smooth micro-step driven dimming

## Zoom

- Motorized zoom with range:		
Fresnel lens	Beam angle	Intensity-center(Lux) at 5 meters
LightMax mode	10°	71800
Minimum zoom	13°	30270
Maximum zoom	44°	7040
Wide-angle lens	Beam angle	Intensity-center (Lux) at 5 meters
LightMax mode	68°	1940
Minimum zoom	75°	1760
Maximum zoom	87°	1690

## Motors

- 14 high quality stepping-motors controlled by microprocessors

## Electronics

- control via control panel with graphic LCD display and 2 buttons/rotating wheel
- Readout fixture and lamp usage, receiving DMX values, temperature, etc
- Built-in analyzer for easy fault finding, error messages
- Remotely switching on/off the lamp by DMX
- Built-in demo sequences
- Silent fans cooling
- Stand alone operation
- Self-resettable thermo-fuse
- Digital serial input DMX-512
- Ethernet connector
- Electronics ballast
- 5 control-channels presettings (17,21,23,24, and 30 control channels)
- Support RDM

## Data input/output

- 3-pin and 5-pin XLR male sockets for DMX data input
- 3-pin and 5-pin XLR female sockets for DMX data output
- RJ-45 male socket for Ethernet connection

## Pan/Tilt

- Pan movement range 530°
- Tilt movement range 280°
- 16 bit movement resolution
- Automatic Pan/Tilt position correction
- Remotely controllable speed of Pan/Tilt movement for easy programming
- Maximum Pan movement 530° in 4,5 s
- Maximum Tilt movement 280° in 2,6 s

## Rigging

- Stands directly on the floor
- Mounts horizontally or vertically with 2 clamps
- fastening of the clamp brackets in 4 positions
- Safety chain/cord attachment apertures

## Temperatures

- Maximum ambient temperature: 40° C
- Maximum housing temperature of the head: 130° C

## Minimum distances

- Min. distance from flammable surfaces: 1.2 m
- Min. distance to lighted object: 4 m

## Accessories:

Mounting bracket Omega CL assembled (No. 99010420) .....	2 pieces
Module of front wide-angle lens (No. 99010879).....	1 piece
Colour module-Amber (No. 99011348).....	1 piece
Colour module-Light red (No. 99011349).....	1 piece

## Optional accessories:

- Remote control IR (No. 13050419)
- Flash cable RS232/DMX (No.13050624)
- Top hat standard 45 (No.10980044)

Top hat long 70 (No.10980045)  
 Top hat 3-ring 45 (No.10980046)  
 Top hat 3-ring 70 (No.10980050)  
 Module of lens D200 PC (No.99010878-01)

**Beam path - Fresnel lens**

Lamp: MSR 1200 SA

**Beam angle 10°- LightMax mode**

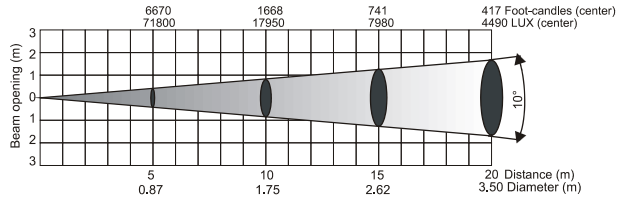

Distance=5m

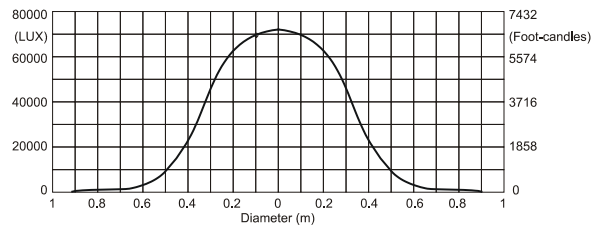

**Beam angle 13°- Min. zoom**

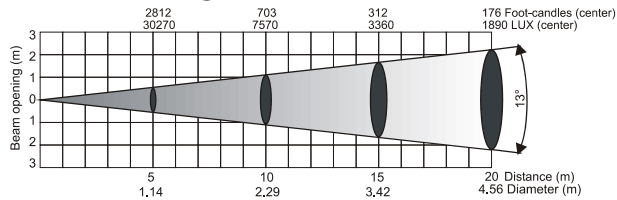

Distance=5m

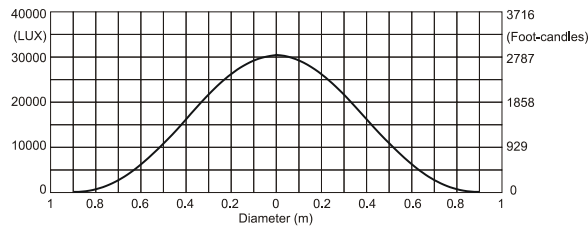

**Beam angle 44°- Max. Zoom**

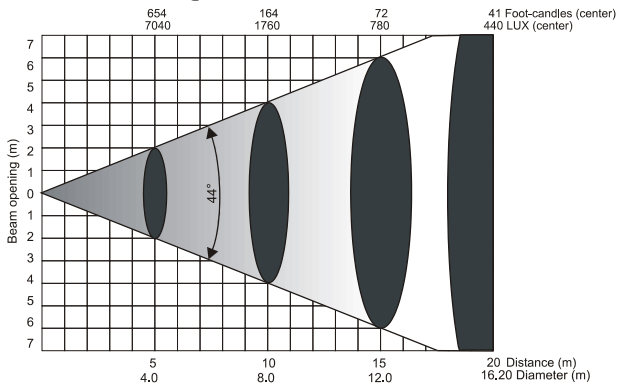

Distance=5m

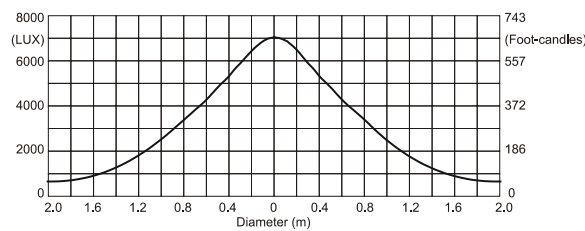

**Dimensions and weight**

- Weight (standard Fresnel lens): 40.8 kg
- Dimensions of the fixture:

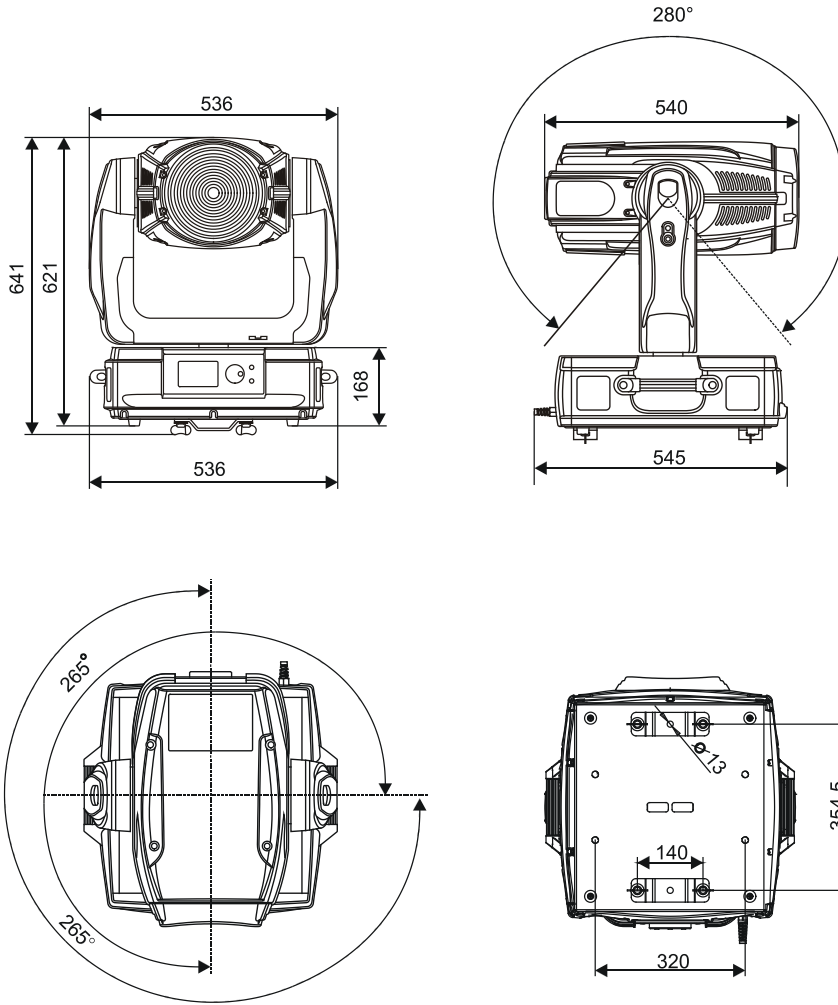

**- Dimensions of the optional top hats:**

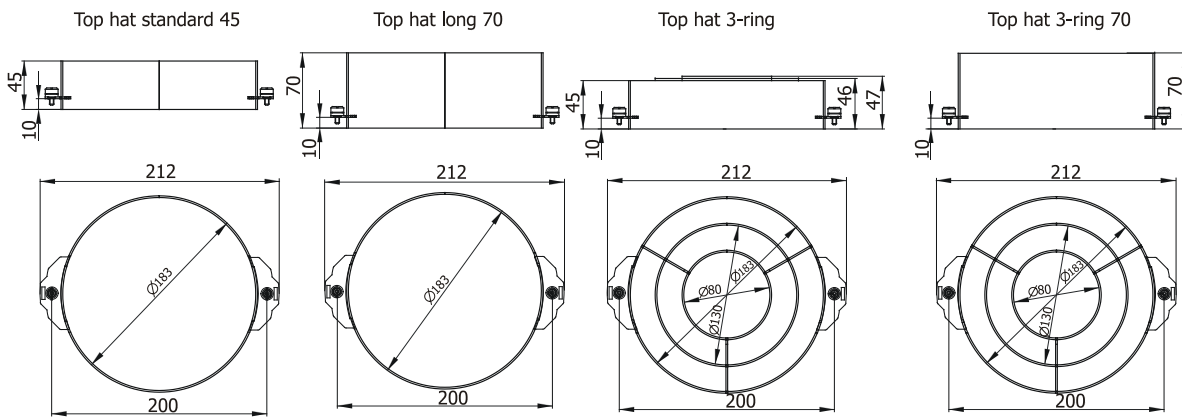

## 14. Maintenance and cleaning

It is absolutely essential that the fixture is kept clean and that dust, dirt and smoke-fluid residues must not build up on or within the fixture. Otherwise, the fixture's light-output will be significantly reduced. Regular cleaning will not only ensure the maximum light-output, but will also allow the fixture to function reliably throughout its life.

A soft lint-free cloth moistened with any good glass cleaning fluid is recommended, under no circumstances should alcohol or solvents be used!

**DANGER ! Disconnect from the mains before starting any maintenance and cleaning work!**

The front objective lens will require weekly cleaning as smoke-fluid tends to building up residues, reducing the light-output very quickly. The cooling-fans should be cleaned monthly.

The interior of the fixture should be cleaned at least annually using a vacuum-cleaner or an air-jet.

Dichroic colour filters, CMY lamelas and the internal lenses should be cleaned monthly.

Remove dust and dirt from the fans and cooling vents using a soft brush and vacuum-cleaner.

**Important! Check the air filters periodically and clean before they become clogged!**

Clean the air filters from the front fans with a vacuum cleaner, compressed air or you can wash them and put back dry.

### Replacing the air filters.

- 1) Disconnect the fixture from power.
- 2) Remove both top and bottom cover of the head (by loosening the 4 quarter-turn fasteners on each cover)
- 3) Remove the air filters (they are fixed with a Velcro fastener) from grids.
- 4) Clean or replace the air filters.
- 5) Place the filters on the grid and put head cover back.
- 6) Reset the elapsed time counter in menu Fixture information (Fixture Information--->Air Filters---> Elapsed Time.

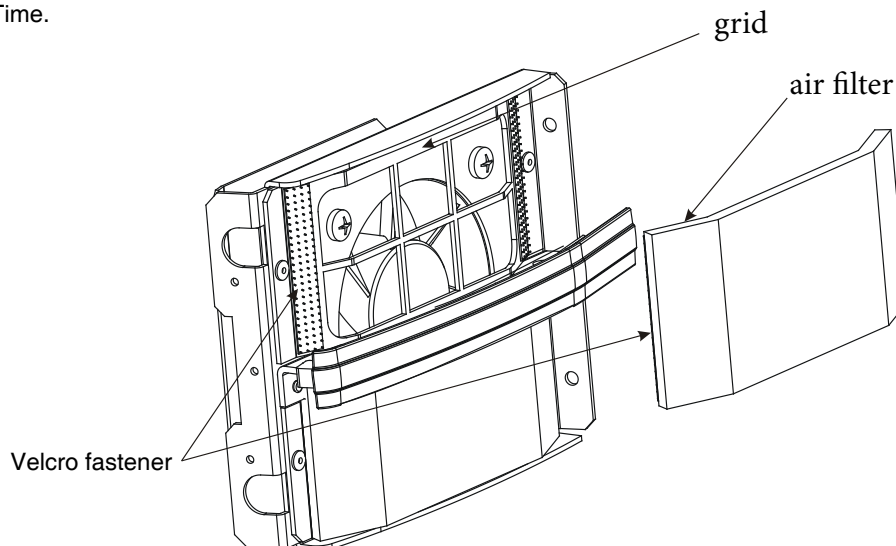

### Replacing the fuse.

If the lamp burns out, the fine-wire fuse of the device might fuse, too. Only replace the fuse by a fuse of the same type and rating.

Before replacing the fuse, unplug mains lead.

- 1) Unscrew the fuse holder on the rear panel of the base with a fitting screwdriver from the housing (anti-clockwise).
- 2) Remove the old fuse from the fuse holder.
- 3) Install the new fuse in the fuse holder.
- 4) Replace the fuseholder in the housing and fix it.

More complicated maintenance and service operations are only to be carried out by authorized dealers.

**Specifications are subject to change without notice.**

