

---

# **ROBE**

---

## **ROBIN<sup>®</sup> BMFL**

---

**Blade**

## **ROBIN<sup>®</sup> BMFL**

---

**Blade Wireless DMX  
CRMX<sup>™</sup>**

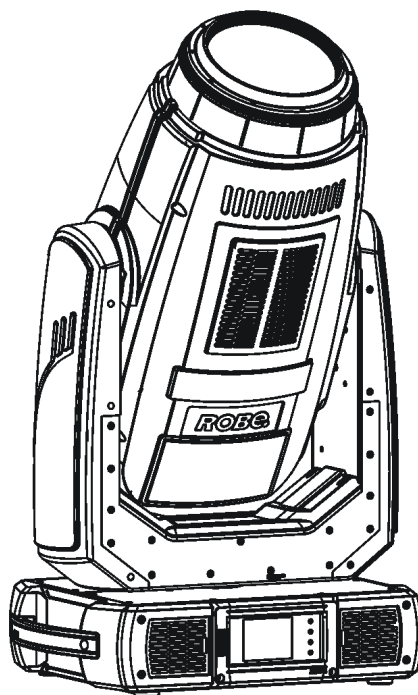

 **ROBIN<sup>®</sup>**  
Innovative Technology

---

**USER MANUAL**

*Version 1.9*

# Robin BMFL Blade

## Table of contents

<b>1. Safety instructions</b> .....	<b>3</b>
<b>2. Operating determination</b> .....	<b>4</b>
<b>3. Fixture exterior view</b> .....	<b>5</b>
<b>4. Installation</b> .....	<b>6</b>
4.1 Connection to the mains .....	6
4.2 Installing the lamp .....	7
4.3 Lamp adjustment .....	7
4.4 Replacing colour filters .....	8
4.5 Replacing rotating gobos .....	9
4.6 Installing handle for the Follow Spot Mode .....	10
4.7 Replacing light frost .....	10
4.8 Rigging the fixture .....	12
4.9 DMX-512 connection.....	14
4.10 Ethernet connection .....	15
<b>5. Remotely controllable functions</b> .....	<b>17</b>
<b>6. Control menu map</b> .....	<b>19</b>
<b>7. Control menu</b> .....	<b>22</b>
7.1 Tab "Address" .....	23
7.2 Tab "Information" .....	24
7.3 Tab "Personality" .....	26
7.4 Tab "Manual Control".....	28
7.5 Tab "Stand-alone" .....	28
7.6 Tab "Service" .....	29
7.7 Icon "Lamp menu" .....	32
<b>8. RDM</b> .....	<b>33</b>
<b>9. Wireless DMX operation</b> .....	<b>33</b>
<b>10. Error and information messages</b> .....	<b>35</b>
<b>11. Technical Specifications</b> .....	<b>39</b>
<b>12. Maintenance and cleaning</b> .....	<b>44</b>
<b>13. Change log</b> .....	<b>44</b>

**CAUTION!**  
**Keep this device away from rain and moisture!**  
**Unplug mains lead before opening the housing!**

**FOR YOUR OWN SAFETY, PLEASE READ THIS USER MANUAL CAREFULLY  
BEFORE YOU INITIAL START - UP!**

## 1. Safety instructions

Every person involved with installation and maintenance of this device have to:

- be qualified
- follow the instructions of this manual

**CAUTION!**  
**Be careful with your operations.**  
**With a high voltage you can suffer**  
**a dangerous electric shock when touching the wires!**

This device has left our premises in absolutely perfect condition. In order to maintain this condition and to ensure a safe operation, it is absolutely necessary for the user to follow the safety instructions and warning notes written in this manual.

### **Important:**

The manufacturer will not accept liability for any resulting damages caused by the non-observance of this manual or any unauthorized modification to the device.

Please consider that damages caused by manual modifications to the device are not subject to warranty.

During the operation the housing becomes hot). Allow the fixture to cool approximately 20 minutes prior to manipulate with it.

Make sure that the available voltage is not higher than stated on the rear panel.

WARNING! This unit does not contain an ON/OFF switch. Always disconnect power input cable to completely remove power from unit when not in use or before cleaning or servicing the fixture.

Make sure that the power-cord is never crimped or damaged by sharp edges. Check the device and the power-cord from time to time.

Always disconnect from the mains, when the device is not in use or before cleaning it. Only handle the power-cord by the plug. Never pull out the plug by tugging the power cord.

This device falls under protection class I. Therefore it is essential to connect the yellow/green conductor to earth.

The electric connection, repairs and servicing must be carried out by a qualified employee. Do not connect this device to a dimmer pack.

Do not switch the fixture on and off in short intervals as this would reduce the lamp's life.

During the initial start-up some smoke or smell may arise. This is a normal process and does not necessarily mean that the device is defective.

Do not touch the device's housing bare hands during its operation (housing becomes hot)! For replacement use lamps and fuses of same type and rating only.

**CAUTION ! EYE DAMAGES !**  
**Avoid looking directly into the light source**  
**(meant especially for epileptics) !**

## 2. Operating determination

This device is a moving head for creating decorative effects and was designed for indoor use only. This device is for professional use only. It is not for household use.

If the device has been exposed to drastic temperature fluctuation (e.g. after transportation), do not switch it on immediately. The arising condensation water might damage your device. Leave the device switched off until it has reached room temperature.

Before switching the fixture OFF, turn the lamp OFF and allow the fixture to cool for a while.

**Attention: The powerCON is a connector without breaking capacity, i.e. the powerCON should not be connected or disconnected under load or live!**

Never run the device without lamp!

Do not shake the device. Avoid brute force when installing or operating the device.

Never lift the fixture by holding it at the projector-head, as the mechanics may be damaged. Always hold the fixture at the transport handles.

When choosing the installation-spot, please make sure that the device is not exposed to extreme heat, moisture or dust. There should not be any cables lying around. You endanger your own and the safety of others!

The minimum distance between light output and the illuminated surface must be more than 8 meters.

Make sure that the area below the installation place is blocked when rigging, derigging or servicing the fixture.

Always fix the fixture with an appropriate safety rope. Fix the safety rope at the correct holes only.

Only operate the fixture after having checked that the housing is firmly closed and all screws are tightly fastened. The lamp must never be ignited if the objective-lens or any housing-cover is open, as discharge lamps may explode and emit a high ultraviolet radiation, which may cause burns.

The maximum ambient temperature 45°C must never be exceeded.

**CAUTION!**  
***The lens has to be replaced when it is obviously damaged, so that its function is impaired, e. g. due to cracks or deep scratches!***

Operate the device only after having familiarized with its functions. Do not permit operation by persons not qualified for operating the device. Most damages are the result of unprofessional operation!

**CAUTION!**  
***The lamp shall be changed if it has become damaged or thermally deformed***

Please use the original packaging if the device is to be transported.

Please consider that unauthorized modifications on the device are forbidden due to safety reasons!

If this device will be operated in any way different to the one described in this manual, the product may suffer damages and the guarantee becomes void. Furthermore, any other operation may lead to dangers like short-circuit, burns, electric shock, burns due to ultraviolet radiation, lamp explosion, crash etc.

**NOTE!**  
***If the lamp is off (and fixture is connected to mains), both colour wheels cannot be controlled by the control panel or DMX command. To control them, switch the lamp on.***

**CAUTION!**  
***To avoid damage of the internal parts of the fixture head, never let the sunlight or other fixture lights directly to the front lens, even when the fixture is not working!***

### 3. Fixture exterior view

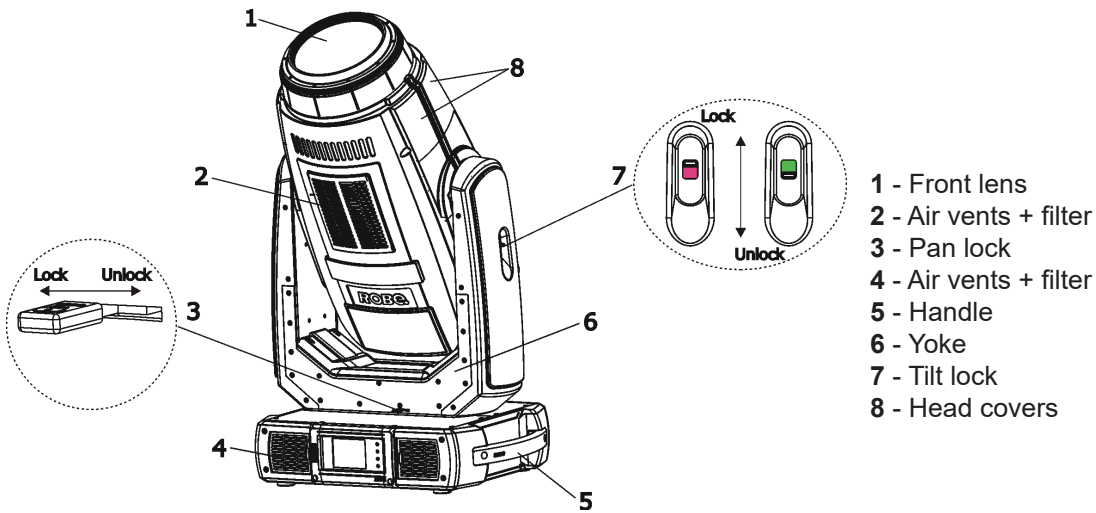

- 1 - Front lens
- 2 - Air vents + filter
- 3 - Pan lock
- 4 - Air vents + filter
- 5 - Handle
- 6 - Yoke
- 7 - Tilt lock
- 8 - Head covers

The head should be locked for transportation - the tilt lock (7) and the pan lock (3) have to be in the locked positions. To unlock the head, move these latches to unlock positions before operating the fixture.

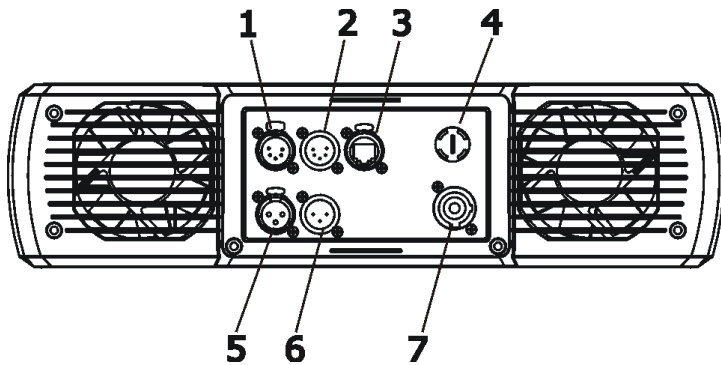

- Rear panel of the base:**
- 1 - DMX output (5-pin XLR)
  - 2 - DMX input (5-pin XLR)
  - 3 - Ethernet input (RJ45)
  - 4 - Fuse holder
  - 5 - DMX output (3-pin XLR)
  - 6 - DMX input (3-pin XLR)
  - 7 - Power input (Neutrik PowerCon)

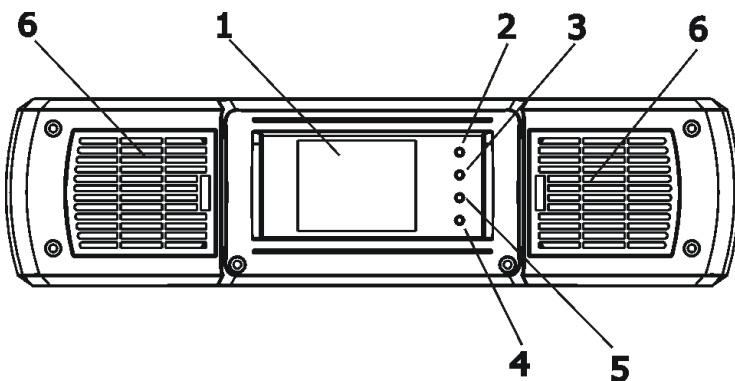

- Front panel of the base:**
- 1 - Touch screen
  - 2 - ESCAPE button
  - 3 - NEXT button
  - 4 - PREVIOUS button
  - 5 - ENTER/DISPLAY ON button
  - 6 - Dust filters

The ENTER/DISPLAY ON button also serves for switching the display on when the fixture is disconnected from the mains.

## 4. Installation



**Fixtures must be installed by a Qualified electrician in accordance with all national and local electrical and construction codes and regulation.**

### 4.1 Connection to the mains

**For protection from electric shock, the fixture must be earthed!**

The Robin BMFL Blade is equipped with auto-switching power supply that automatically adjusts to any 50-60Hz AC power source from 200-240 Volts. The fixture is protected by one 12 A blow primary fuse.

If you install a cord cap on the power cable to allow connection to power outlets, install a grounding-type (earthed) plug, following the plug manufacturer's instructions.

To apply power, first check that the head pan and tilt locks are released.

The cores in the power cable are coloured according to the following table.

Core (EU)	Core (US)	Connection	Plug Terminal Marking
Brown	Black	Live	L
Light blue	White	Neutral	N
Yellow/Green	Green	Earth	

The earth has to be connected!

If you have any doubts about proper installation, consult a qualified electrician.

**Attention: The powerCON is a connector without breaking capacity, i.e. the powerCON should not be connected or disconnected under load or live!**

**Do not connect the fixture to a dimmer system!**

## 4.2 Installing the lamp

**DANGER ! Install the lamp with the device switched off only.  
Unplug from mains before !**

### To insert the new lamp.

1. Disconnect the fixture from power and allow it to cool at least 20 minutes.
2. Make sure that the fixture's head is in the position as shown on the picture (notices on the lamp cover are in a readable position). Loosen the three quarter-turn fasteners (1) on the lamp cover to open this cover.
3. Holding the lamp by its ceramic base, carefully turn the lamp to the left to loosen the lamp from the lamp holder.  
Gently pull the lamp out of the lamp holder
4. Holding the new lamp by its ceramics base and keeping its orientation as shown at the picture below, gently insert the lamp to the lamp holder and turn its base to the right until two lamp electrodes snap into slots in the lamp holder. Make sure that the lamp is installed tightly into the lamp socket.  
Do not install a lamp with a higher wattage! A lamp like this generates temperatures the device is not designed for. Damages caused by non-observance are not subject to warranty.  
Please follow the lamp manufacturer's notes! Do not touch the glass bulb bare hand during the installation!
5. Re-insert the lamp cover and tighten the three quarter-turn fasteners (1).
6. Switch on the fixture.
7. Align the lamp (see instructions below)
8. Reset the "Lamp On Time" and "Lamp Strikes" counters in the menu "Information".

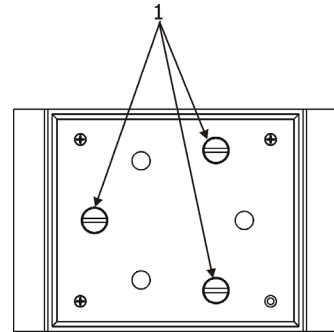

**Do not operate this fixture with open lamp cover!**

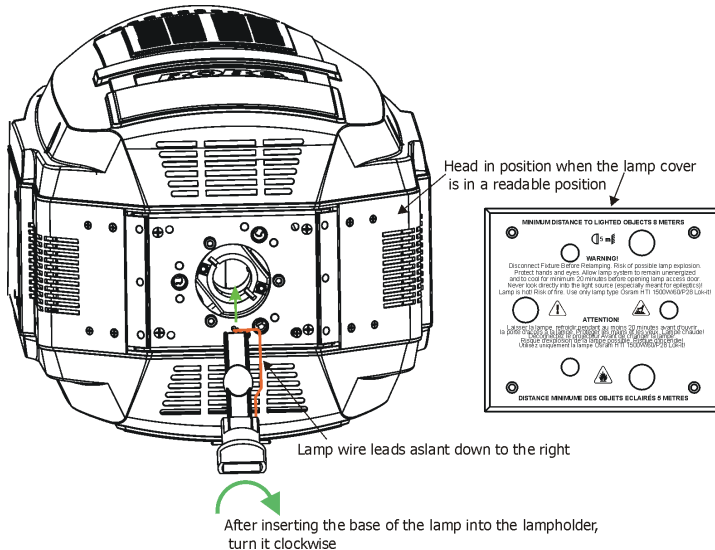

## 4.3 Lamp adjustment

The lamp holder is aligned at the factory. Due to differences between lamps, the fine adjustment may improve light performance:

### To adjust the lamp in the fixture.

1. Switch on the fixture and after its reset turn on the lamp.
2. Go to the "Service" menu and select the item "Adjust Lamp" to project the light beam on the wall.
3. Use items in this menu to focus the light beam
4. Turn adjustment screws (2) one after another until you center the hot spot (the brightest part of the beam) and reach a max. light intensity at desired light distribution.

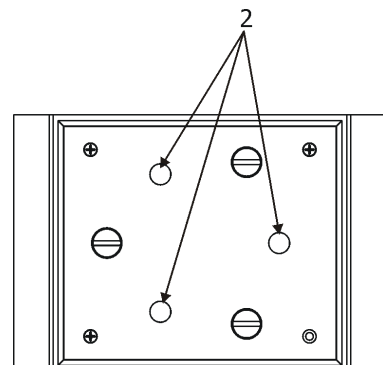

## 4.4 Replacing colour filters

***Install colour filters with the device switched off only.  
Unplug from mains before!***

### Colour filters

1. Disconnect the fixture from mains and allow it to cool 10 minutes.
2. Remove the plastic cover of the head by loosening the 4 quarter-turn fasteners on the cover.
3. Turn the colour wheel 2 to the suitable position.  
The dichroic filters are fixed on the colour wheel by the magnets.
4. Release the dichroic filter (1) from the colour wheel 2 by inclining it from its position to break the power of the magnet. Protect the glass filter with a piece of paper or clout.
5. Insert a new dichroic filter into the colour wheel 2.
6. Place the top cover back before applying power.

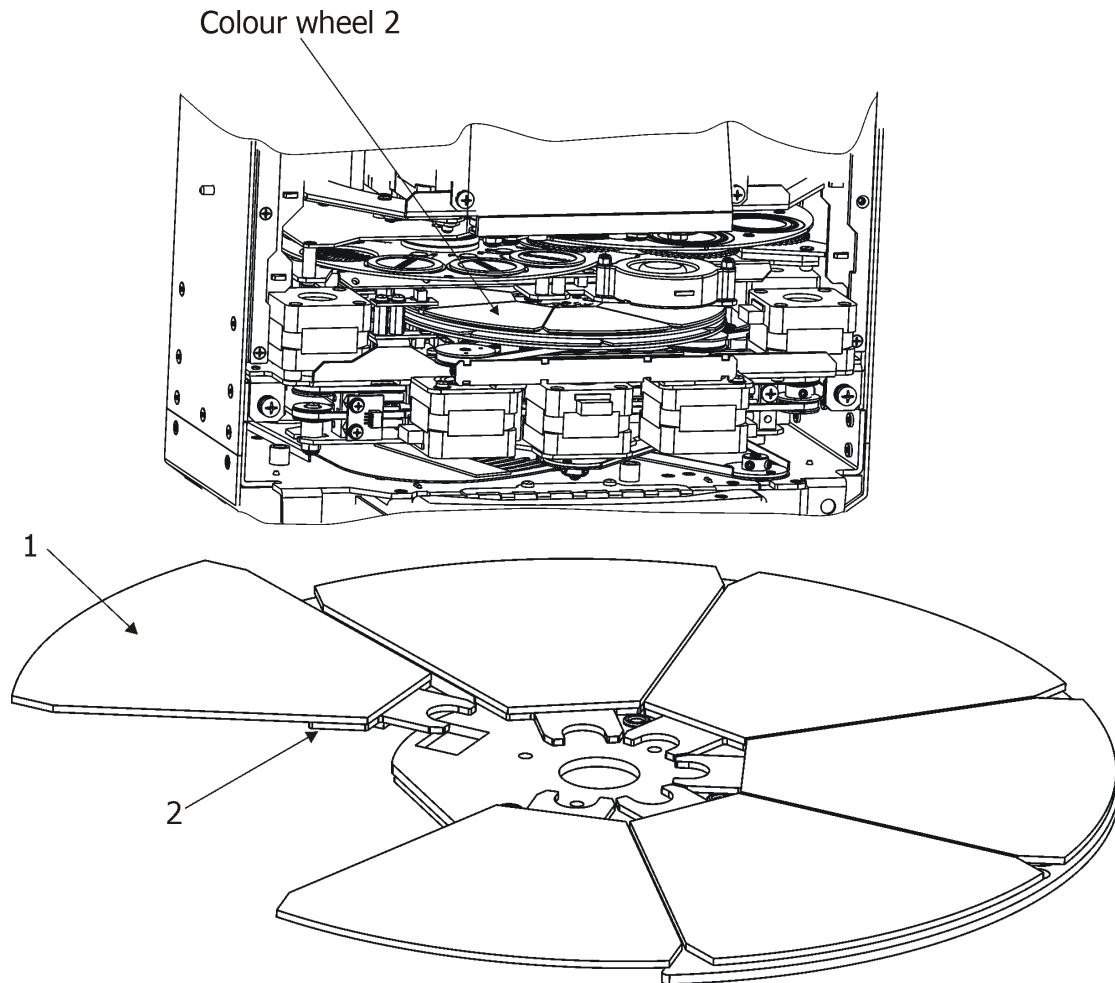



## 4.5 Replacing rotating gobos

**Install gobos with the device switched off only.  
Unplug from mains before!**

To replace rotating gobos.

1. Disconnect the fixture from mains and allow it to cool for 10 minutes .
2. Remove the plastic cover of the head by loosening the 4 quarter-turn fasteners on the cover.
3. Gently pull up the gobo holder (3) from the rotation gobo wheel.
4. Remove the spring lock (1) with an appropriate tool (e.g. small-bladed screwdriver) and remove it.  
Do not touch the surface of the pattern of the glass gobo with bare fingers.
5. Remove the original gobo (2) and insert the new one (glazy side towards the lamp).

The Robe gobo has a small position point (8) at its edge which has to aim at the position point (4) on the gobo holder (3). Insert the spring lock to secure correct gobo position in the gobo holder.

6. Insert the gobo holder back under the distance slots (6, 7) into rotating gobo wheel in this way, that its position point (4) has to aim at a small toothlike projection (5) on the edge of the rotating gobo wheel.

**Important!** When inserting the gobo holder back to the rotating gobo wheel, one of the adjacent gobo holder has to be oriented according to the same rule, it means that its position point (4) has to aim at the toothlike projection (5) on the edge of the rotating gobo wheel. You have keep both marks (4) and (5) side by side when rotate the gobo wheel to the position allows inserting the gobo holder back.

5. Place the plastic cover back before applying power.
6. Use the menu Service to fine adjust replaced gobo (Service -> Calibration -> Calibrate effects -> R. Gobo Index 1....6).

Note. The magnet (9) of the gobo holder has the same function as the position point (4) on the rest of gobo holders.

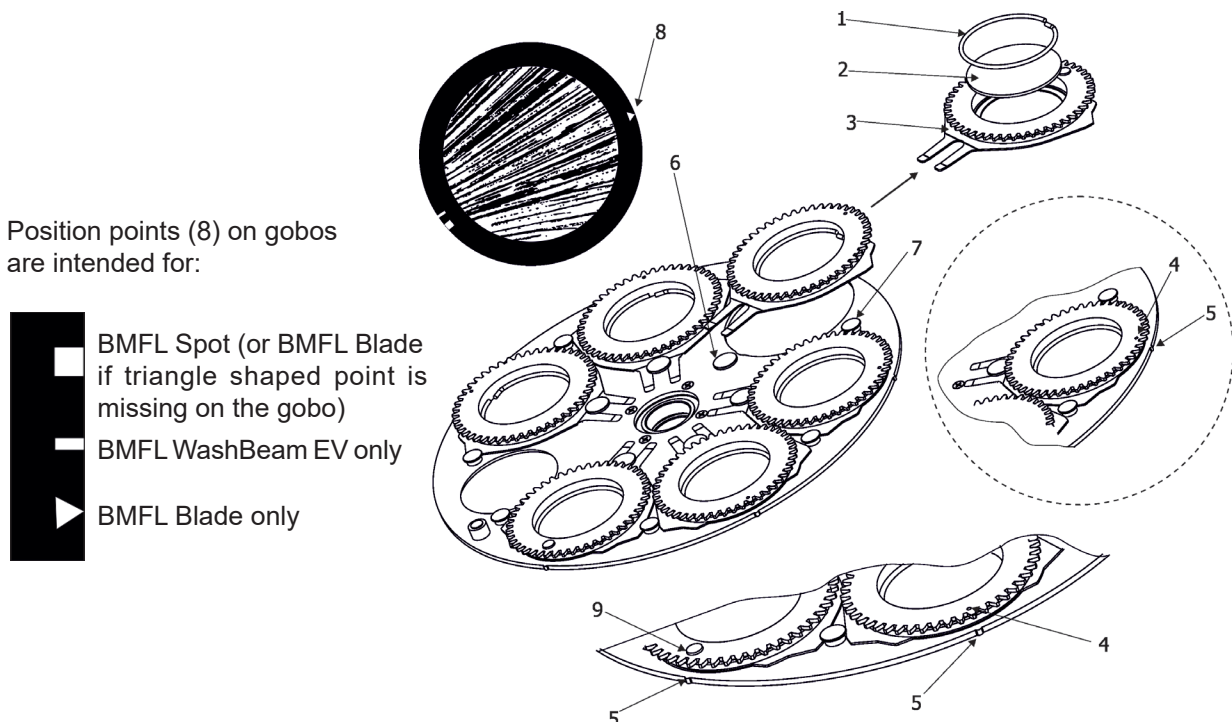

Note: First three gobos have the position point (8) triangle shaped, the second three gobos have the position point square shaped.

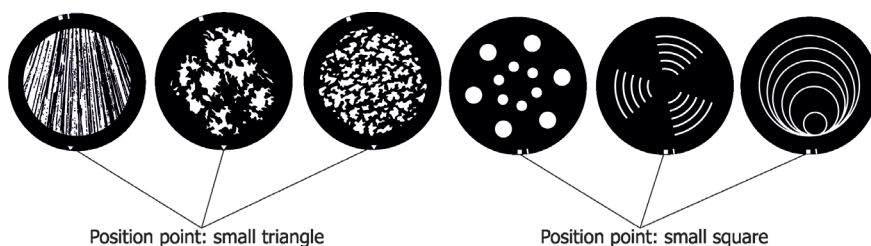

## 4.6 Installing BMFL handles for the Follow Spot Mode

Before installation of handle (handles), switch the fixture to the Follow Spot Mode (Personality--> Follow Spot Mode). You can install one or two handles in different positions as needed. See picture below. Before switching the Follow Spot Mode off, remove handle (handles) from the fixture.

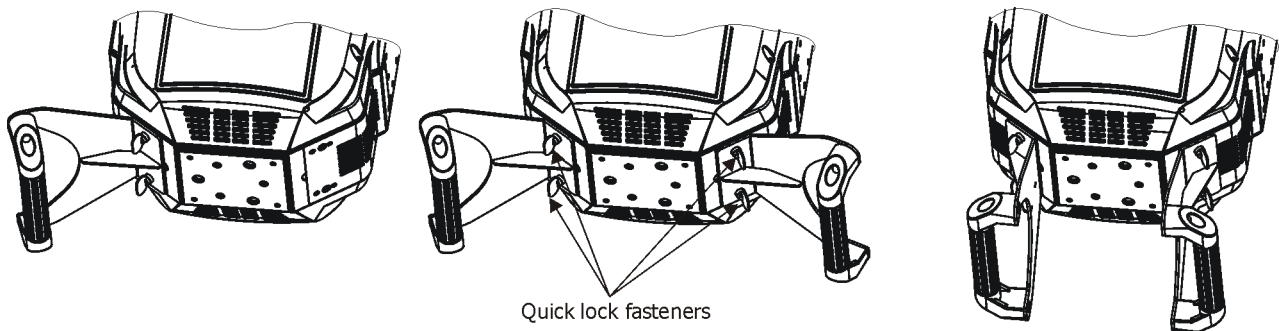

## 4.7 Replacing light frost

**Install light frost module with the device switched off only.  
Unplug from mains before!**

To replace the light frost module.

1. Disconnect the fixture from mains and allow it to cool for 10 minutes.
2. Move the head to the position that signs on the lamp cover (1) lead down (turned by 180°)
3. Remove plastic cover of the head by loosening the 4 quarter-turn fasteners on the cover.
4. Remove the fan assembly (2) by unscrewing two screws (3) on both sides of the fan assembly.

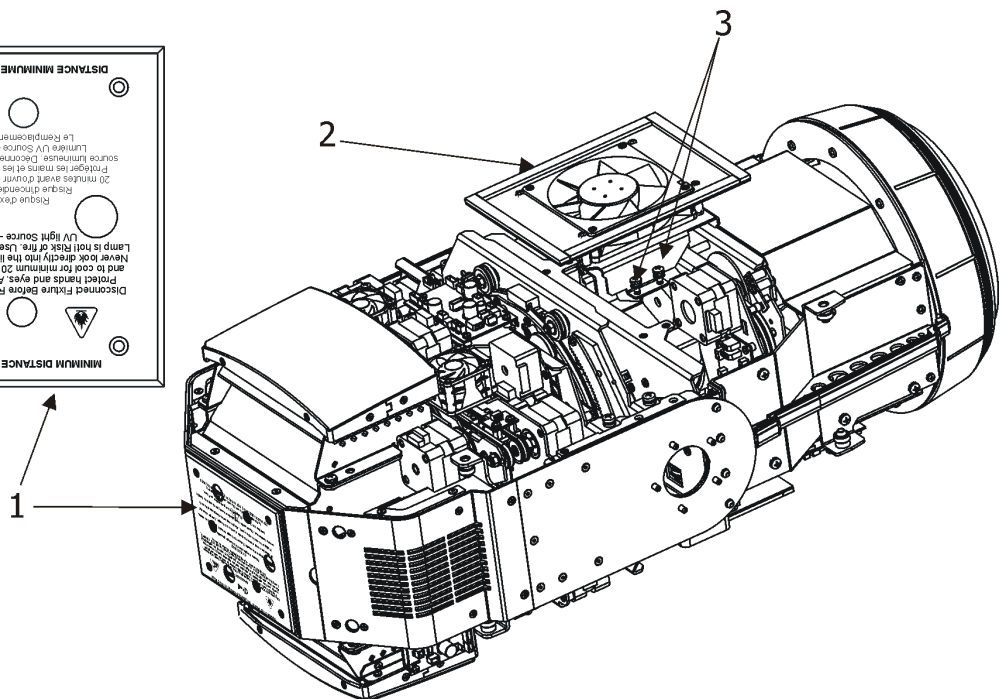

5. Insert with caution a flat-tip screwdriver between the metal sheet of the frost module (4) and the frost holder (5) and gently turn the screwdriver to break a force of magnets (6) on the frost holder (5) and pull the light frost module (4) out from the fixture. The Frost module (4) is fastened to the frost holder (5) by means of the four magnets (6).

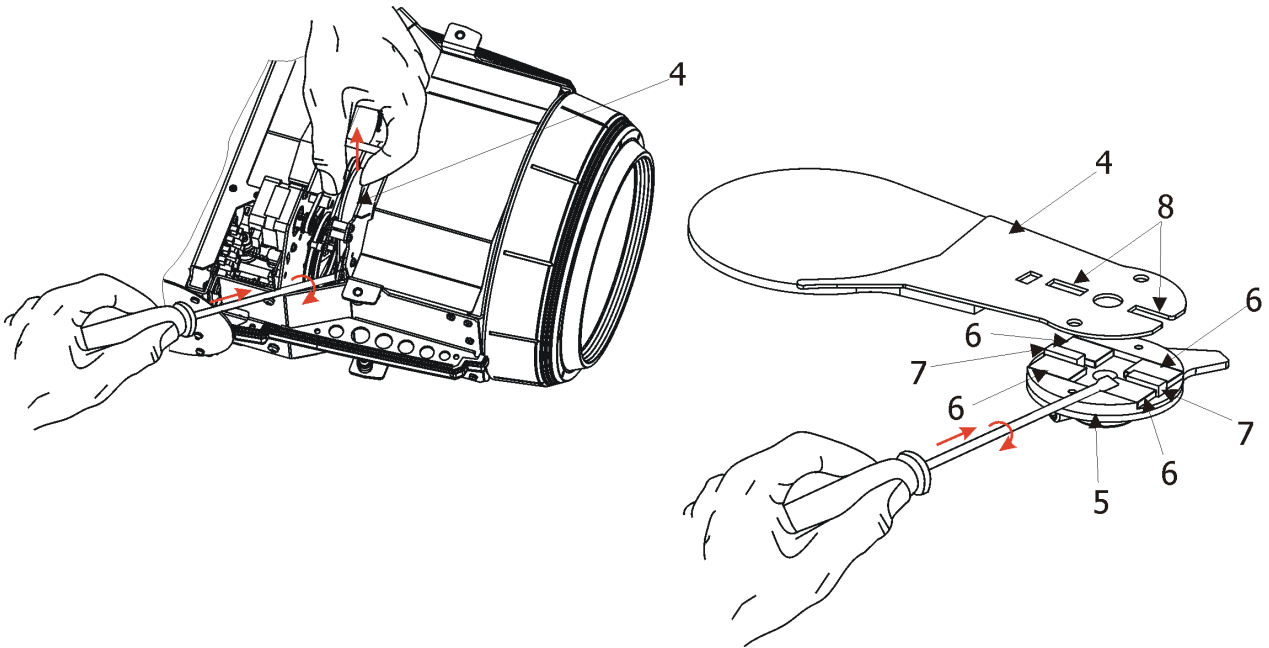

6. Insert new frost module in the frost holder (5). Check, that both slots (8) snapped correctly into two protrusions (7) on the frost holder (5)
7. Screw the fan assembly (2) back to the fixture and place the plastic cover back on the fixture before applying power.

## 4.8 Rigging the fixture

A structure intended for installation of the fixture(s) must safely hold weight of the fixture(s) placed on it. The structure has to be certificated to the purpose.

The fixture (fixtures) must be installed in accordance with national and local electrical and construction codes and regulation.

***For overhead installation, the fixture must be always secured with a safety wire that can bear at least 10 times the weight of the fixture***

When rigging, derigging or servicing the fixture staying in the area below the installation place, on bridges, under high working places and other endangered areas is forbidden.

The operator has to make sure that safety-relating and machine-technical installations are approved by an expert before taking into operation for the first time and after changes before taking into operation another time.

The operator has to make sure that safety-relating and machine-technical installations are approved by a skilled person once a year.

Allow the fixture to cool for ten minutes before handling.

The projector should be installed outside areas where persons may walk by or be seated.

IMPORTANT! OVERHEAD RIGGING REQUIRES EXTENSIVE EXPERIENCE, including calculating working load limits, installation material being used, and periodic safety inspection of all installation material and the projector. If you lack these qualifications, do not attempt the installation yourself, but use a help of professional companies.

CAUTION: Fixtures may cause severe injuries when crashing down! If you have doubts concerning the safety of a possible installation, do not install the fixture!

The fixture has to be installed out of the reach of public.

The fixture must never be fixed swinging freely in the room.

**Danger of fire !**  
**When installing the device, make sure there is no highly inflammable material (decoration articles, etc.) in a distance of min. 1 m.**

**The minimum distance of 8 meters between light output from the moving head and the lit objects must be kept!**

**CAUTION!**  
**Use 2 appropriate clamps to rig the fixture on the truss.**  
**Follow the instructions mentioned at the bottom of the base.**  
**Make sure that the device is fixed properly! Ensure that the structure (truss) to which you are attaching the fixtures is secure.**

The fixture can be placed directly on the stage floor or rigged in any orientation on a truss without altering its operation characteristics .

For securing a fixture to the truss, install two safety wires which can hold at least 10 times the weight of the fixture. Use only the safety wires with screw-on carabines.

**Omega holders positions:**

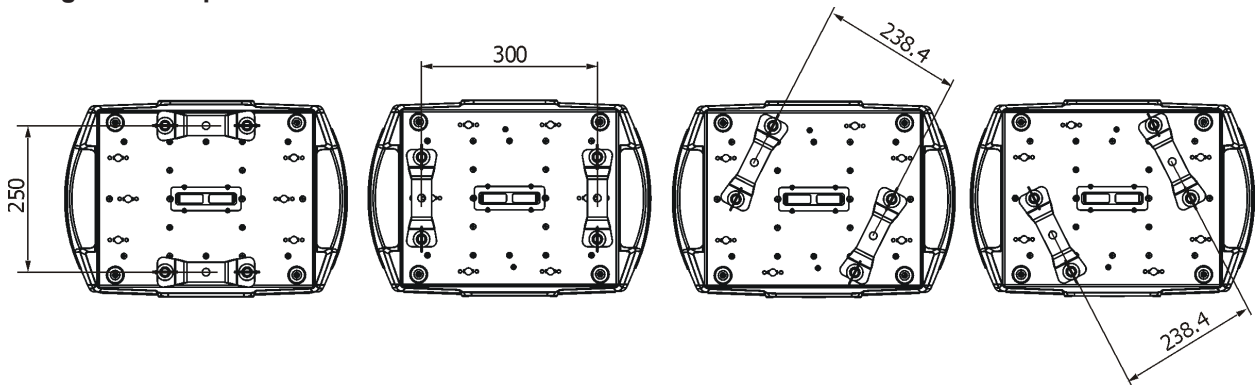

**Truss installation**

1. Bolt each clamp (1) to the omega holder (2) with M12 bolt and lock nut through the hole in the holder.
2. Fasten the omega holders to the bottom of the base by inserting both quick-lock fasteners (3) into the holes of the base and tighten fully clockwise.
3. Clamp the fixture on a truss (6) and tighten the rigging clamps.
4. Pull one safety wire (4) around the truss (6) and through the handle (7) and another safety wire (4) pull around the truss (6) and through the handle (7) and lock the screw-on carabine through attachment point (5) as shown on the picture below.

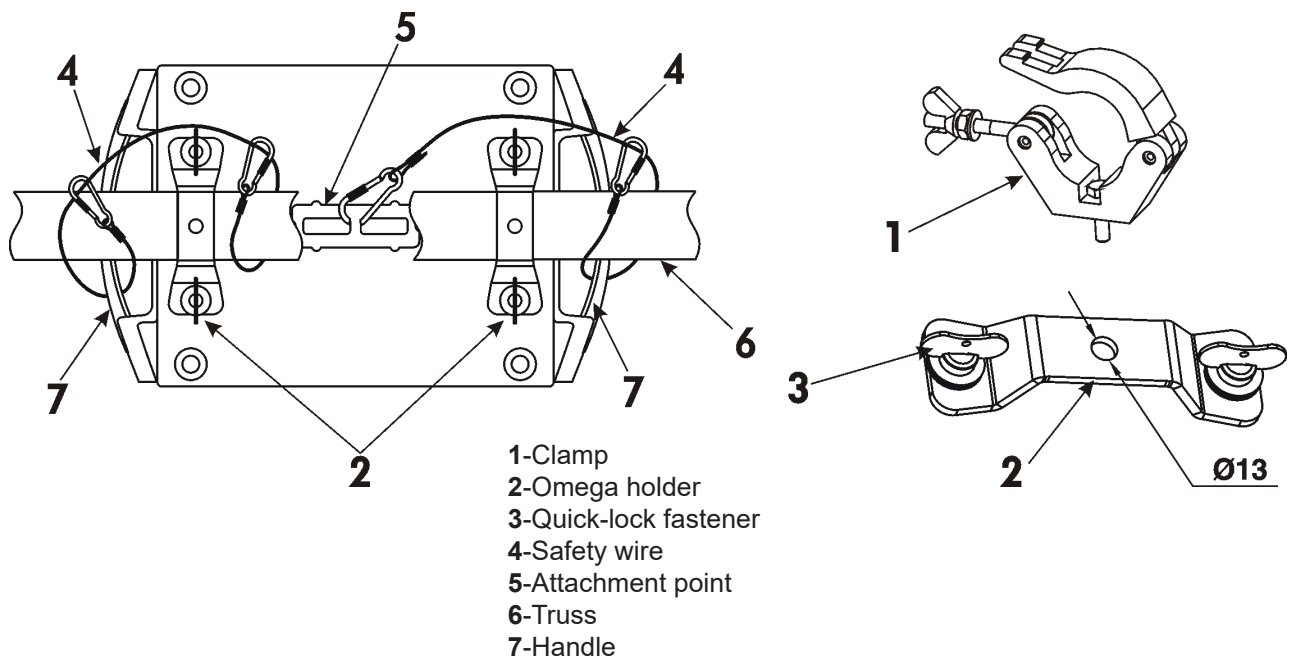

**When installing fixtures side-by-side, avoid illuminating one fixture with another!**

**In order to protect the internal parts of the head from the sun, the function HOME POSITION must be switched ON before switching the fixture off.**

The HOME POSITION function is located on the Power/Special functions channel (70-79 DMX). If the function is on, the fixture will automatically detect via G-sensor whether the fixture is on the floor or hangs on the truss or is mounted sideways on the truss and moves the pan and tilt to the position (including movement of zoom and focus lenses to the front part of the head) in which the front lens of the head will always face down. Owing this position of the fixture head, there is not chance to burn internal parts of the head by sun light.

## 4.9 DMX-512 connection

The fixture is equipped with both 3-pin and 5-pin XLR sockets for DMX input and output. The sockets are wired in parallel.

Only use a shielded twisted-pair cable designed for RS-485 and 3-pin or 5-pin XLR-plugs and connectors in order to connect the controller with the fixture or one fixture with another.

### DMX - output

XLR mounting-sockets (rear view):

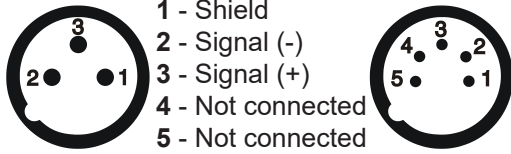

### DMX-input

XLR mounting-plugs (rear view):

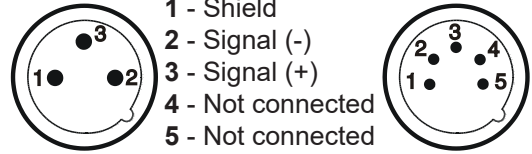

If you are using the standard DMX controllers, you can connect the DMX output of the controller directly with the DMX input of the first fixture in the DMX-chain. If you wish to connect DMX controllers with other XLR outputs, you need to use adapter cables.

### Building a serial DMX-chain:

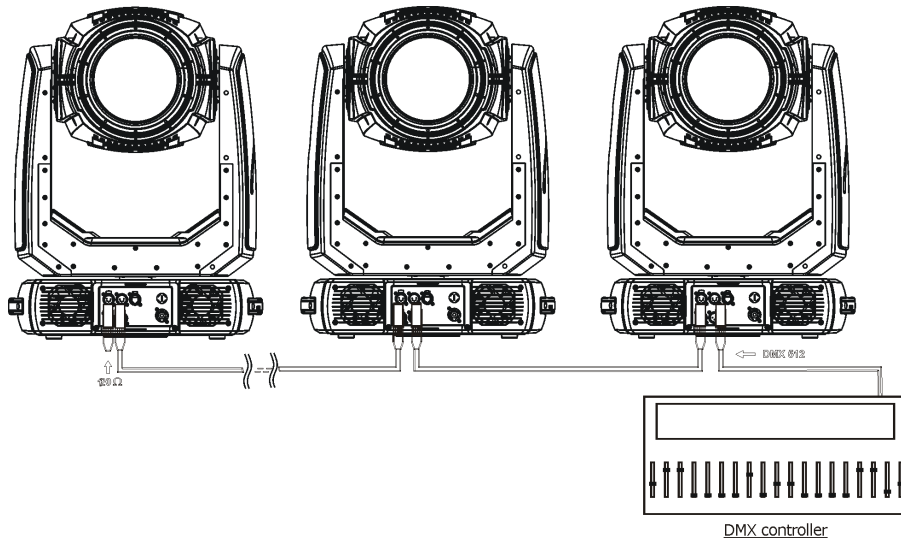

Connect the DMX-output of the first fixture in the DMX-chain with the DMX-input of the next fixture. Always connect one output with the input of the next fixture until all fixtures are connected. Up to 32 fixtures can be connected.

**Caution:** At the last fixture, the DMX-cable has to be terminated with a terminator. Solder a 120  $\Omega$  resistor between Signal (-) and Signal (+) into a 3-pin (5-pin) XLR-plug and plug it in the DMX-output of the last fixture.

## 4.10 Ethernet connection

The fixtures on a data link are connected to the Ethernet with ArtNet communication protocol. The control software running on your PC (or light console) has to support Art-Net protocol.

Art-Net communication protocol is a 10 Base T Ethernet protocol based on the TCP/IP. Its purpose is to allow transfer of large amounts of DMX 512 data over a wide area using standard network technology.

**IP address** is the Internet protocol address. The IP uniquely identifies any node (fixture) on a network.

**The Universe** is a single DMX 512 frame of 512 channels.

The Robin MMX Blade is equipped with 8-pin RJ-45 socket for Ethernet input. Use a network cable category 5 (with four "twisted" wire pairs) and standard RJ-45 plugs in order to connect the fixture to the network.

**RJ-45 socket (front view):**

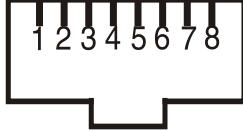

- |                  |                  |
|------------------|------------------|
| 1- TD+           | 5- Not connected |
| 2- TD-           | 6- RX-           |
| 3- RX+           | 7- Not connected |
| 4- Not connected | 8- Not connected |

**RJ-45 plug (front view):**

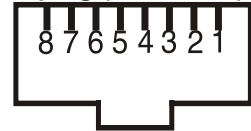

Patch cables that connect fixtures to the hubs or LAN sockets are wired 1:1, that is, pins with the same numbers are connected together:



If only the fixture and the computer are to be interconnected, no hubs or other active components are needed. A cross-cable has to be used:



If the fixture is connected with active Ethernet socket (e.g. switch) the network icon  will appear at the bottom right corner of the screen:

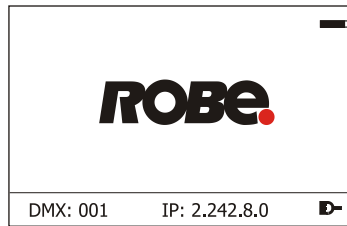

### Direct Ethernet operation

Connect the Ethernet inputs of all fixtures with the Ethernet network.

Option "Artnet" (gMal or gMA2 or sACN) has to be selected from "Ethernet Mode" menu at each fixture.

Set IP address (002.xxx.xxx.xxx / 010.xxx.xxx.xxx) and the Universe at each fixture.

(DMX address=150)  
IP address=002.168.002.004  
Universe=1

(DMX address=42)  
IP address=002.168.002.003  
Universe=1

(DMX address=1)  
IP address=002.168.002.002  
Universe=1

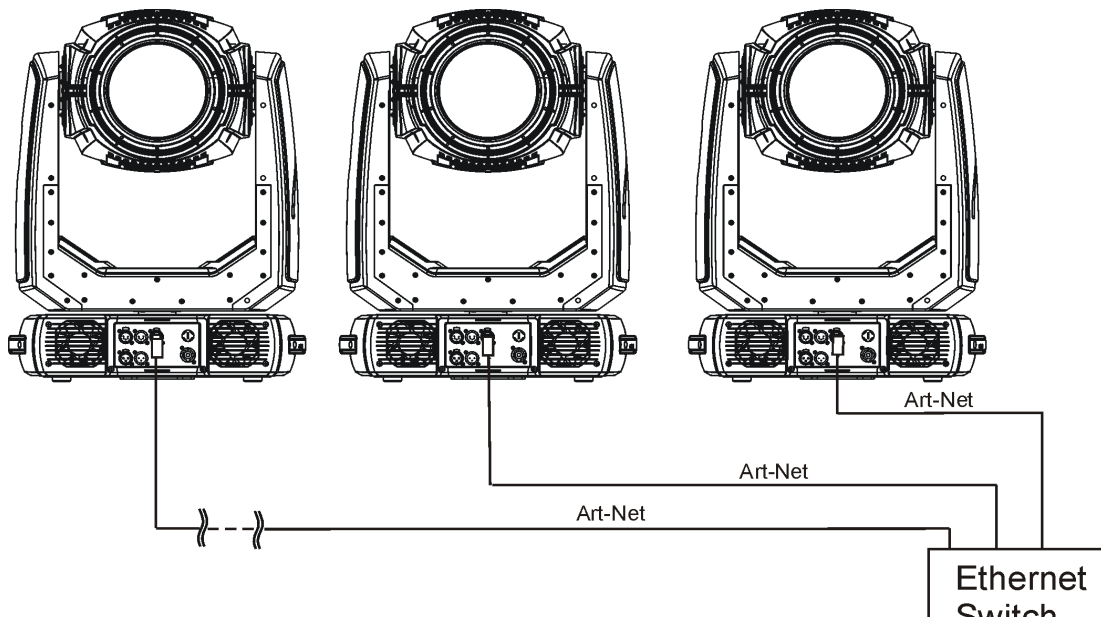

An advised PC setting: IP address: 002.xxx.xxx.xxx / 010.xxx.xxx.xxx (Different from fixture IP addresses)  
NET mask: 255.0.0.0

## Ethernet / DMX operation

Option "Artnet" (gMa1 or gMA2 or sACN) has to be selected from "Ethernet Mode" menu at first fixture.

Option "Ethernet To DMX" has to be selected from the "Ethernet Mode" menu at the first fixture (connected to the Ethernet) in the fixture chain, next fixtures have standard DMX setting.

Connect the Ethernet input of the first fixture in the data chain with the network. Connect the DMX output of this fixture with the input of the next fixture until all fixtures are connected to the DMX chain.

**Caution:** At the last fixture, the DMX chain has to be terminated with a terminator. Solder a 120 Ω resistor between Signal (-) and Signal (+) into a XLR-plug and connect it in the DMX-output of the last fixture.

Example:

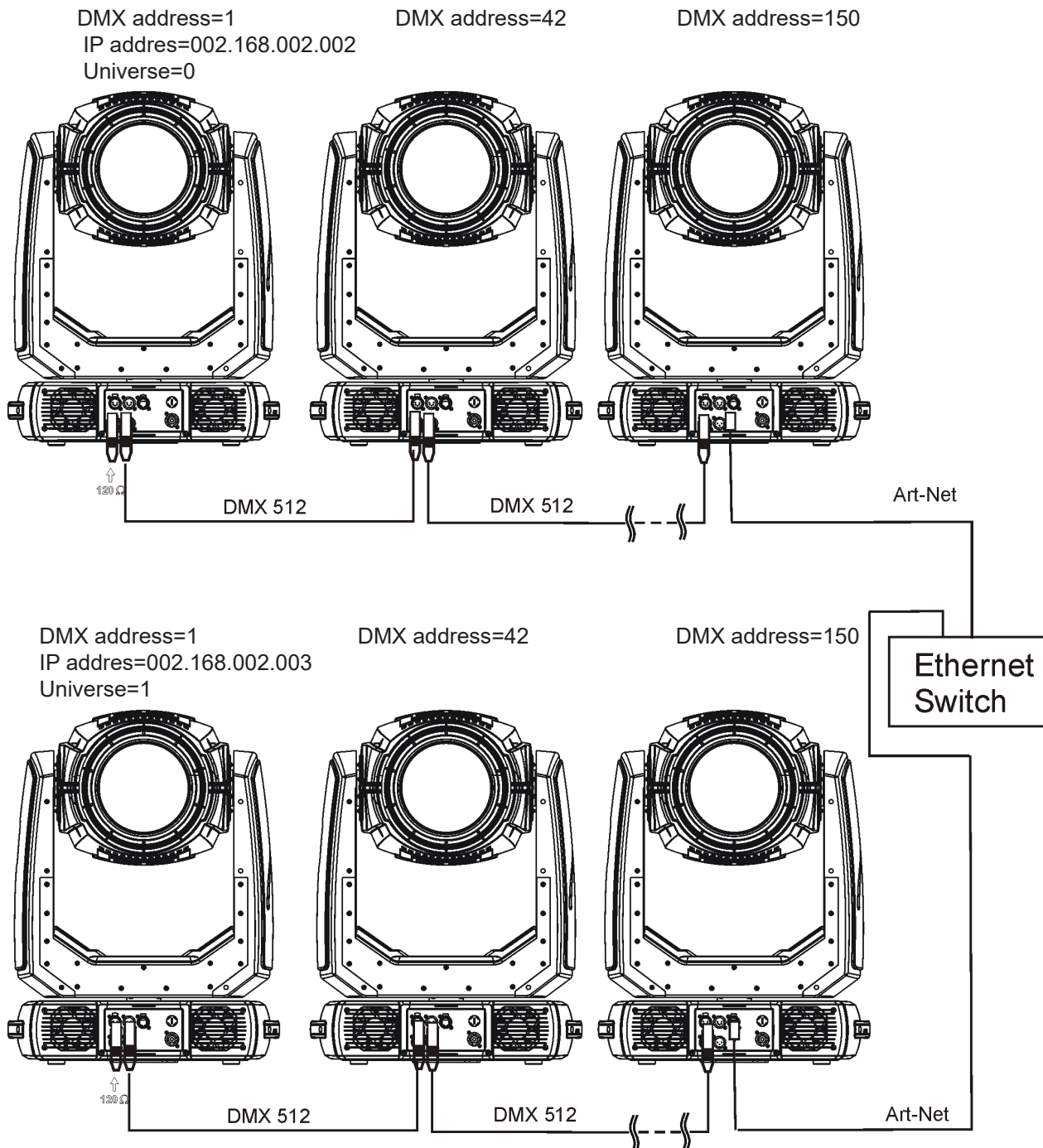



## 5. Remotely controllable functions

### Lamp

The Osram Lok-it! HTI 1700/PS is a highly efficient, single-ended short-arc metal halide lamp with 6000 Kelvin colour temperature. The new Lok-it! plug'n'play system allows a quick one-touch lamp replacement.

The fixture allows three levels of the lamp power: 1700W, 1500W and Quiet (Quiet mode - the lamp power is auto-controlled to ensure minimum noise of fixture fans).

Note: It is also important to note, that the discharge lamp is a cold restrike type, that means, that the lamp has to be cold before re-striking. For this reason, you have to wait a while after having switched the lamp off before you can switch it on again.

### Colour wheel 1

This wheel contains 6 dichroic filters + open. The colour wheel can be positioned between two adjacent colours in any position. It is also possible to rotate the colour wheel continuously at different speeds ("Rainbow effect" in both directions).

### Colour wheel 2

This wheel contains 6 replaceable 'SLOT&LOCK' dichroic filters + open. The colour wheel can be positioned between two adjacent colours in any position. It is also possible to rotate the colour wheel continuously at different speeds ("Rainbow effect" in both directions).

### CMY+CTO colour mixing system

The CMY color mixing system is based on graduated cyan, magenta, and yellow colour filters. A continuous range of colors may be achieved by varying the amount of each filter from 0 to 100%.

### Effect wheel

The effect wheel rotating in both directions with variable speed which creates wide spectrum of graphic effects.

### Gobo wheels

The fixture includes one static gobo wheel with 8 replaceable gobos and one rotating gobo wheel with 6 glass gobos rotating in both directions, indexable, replaceable "SLOT&LOCK" system Gobo positioning and gobo selection speed is available as well as a gobo-shake function.

### Prism

Two rotating prisms (6-facet linear, 6-facet axial) with continuous rotation in both directions. 16 prism/gobo macros available.

### Frost

Frost module provides 3 types of variable frosts: light, medium and heavy.

### Iris

Motorized adjustable iris, wide range of variable pulse effects.

### Zoom

Motorized zoom unit enables zoom between 5° - 55° (open hole); 5° - 48° (gobo).

### Focus

Motorized focus allows to focus beam from approx. 5 metres to infinity.

### Shutter unit

This unit is used for strobe effects with variable speed.

### Dimmer unit

Smooth 0 - 100 % dimming is provided by the mechanical dimmer unit.

## Pan/Tilt

Fast pan/tilt movement due to built-in electronic motion stabilizer. The electronic motion stabilizer ensures precise position of the fixture's head during its movement and reduces its swinging when the truss shakes.

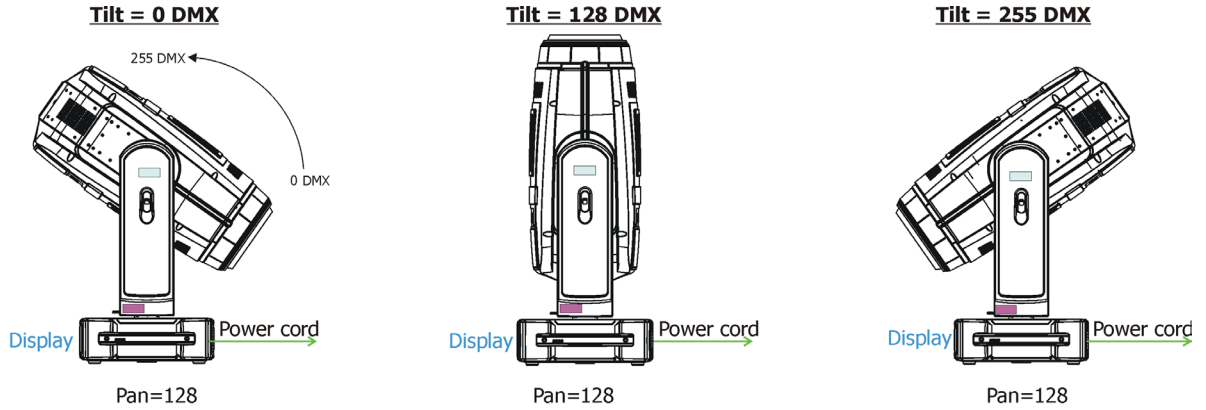

**Tilt movement range: 270° Pan movement range: 540°**

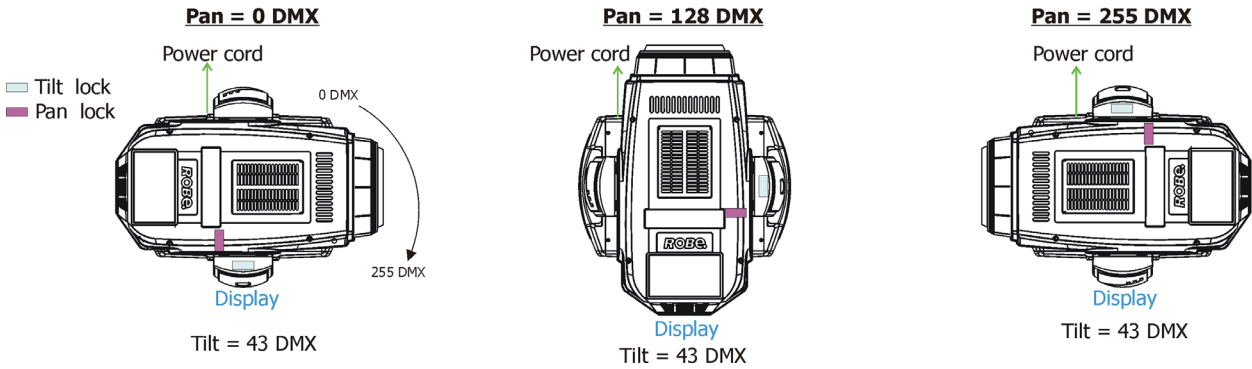

## Framing system

Framing system consists of four framing shutters which can be moved or swivelled to desired position separately.

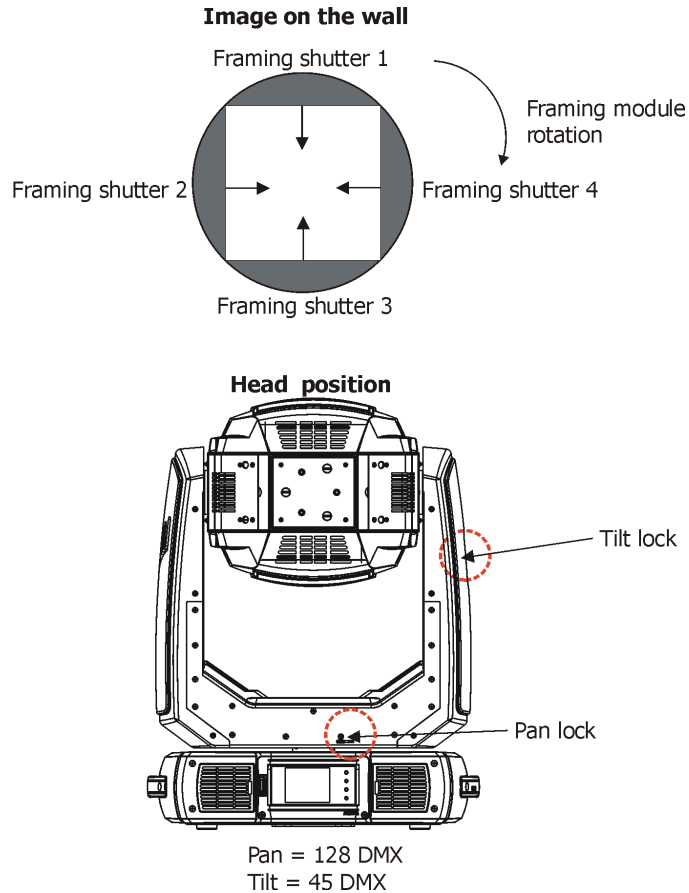



## 6. Control menu map

Default settings=**Bold print**

Tab	Level 1	Level 2	Level 3	Level 4	Level 5	Level 6
Addressing	DMX Address	001-512				
	DMX Presets	<b>Mode 1</b>				
		Mode 2				
		View Selected Preset				
	Ethernet Settings	Ethernet Mode	Disable			
			ArtNet			
			gMA1			
			gMA2			
			sACN			
		Ethernet To DMX	<b>Off</b> , On			
		IP Address/Net Mask	Default IP Address			
			Custom IP Address			
			Net Mask			
		ArtNet Universe	0-255			
		MANet settings	MANet/II Universe	01-256		
			MANet Session ID	01-32		
		sACN Settings	sACN Universe	00001-32000		
			sACN Priority	0-255		
Information	Fixture Times	Power On Time	Total Hours			
			Resetable Hours			
		Lamp On Time	Total Hours			
			Remaining hours			
		Lamp Strikes	Total Strikes			
			Resetable Strikes			
		Air Filters	Elapsed Time			
			Alert Period	10-300		
	Fixture Temperatures	Head Temperature	Current			
			Maximum NonRes.			
			Maximum Res.			
		Ambient Temperature	Current			
			Maximum NonRes.			
			Maximum Res.			
		Base Temperature	Current			
			Maximum NonRes.			
			Maximum Res.			
	DMX Values	Pan				
		:				
		Dimmer Fine				
	Wireless State	Signal Quality				
		Unlink Wireless Adapter				
	Power Channel State					
	Software Versions	Display System				
		Module M				
		Module G				
		Module P				
		Module O				
		Module C				
		Module D				
		Module S				
		Module F-A				
		Module F-B				

Tab	Level 1	Level 2	Level 3	Level 4	Level 5	Level 6
		Wireless				
	Product IDs	Mac Address				
		RDM UID				
		RDM Label				
	View Logs	Fixture Errors				
		Fixture States	Power On			
			Power Off			
			Lamp On			
			Lamp Off			
			Lamp On			
			Lamp Off			
		Fixture Position				
		Fixture Temperatures	Head Temperature			
			Ambient Temperature			
			Base Temperature			
Personality	User Mode	User A Settings				
		User B Settings				
	DMX Presets	<b>Mode 1</b>				
		Mode 2				
		View Selected Preset				
	DMX Input	<b>Wired input</b>				
		Wireless input				
		Wireless In/XLR Out				
	Pan/Tilt Settings	Pan Reverse	<b>Off, On</b>			
		Tilt Reverse	<b>Off, On</b>			
		Pan/Tilt Feedback	<b>Off, On</b>			
		Pan/Tilt mode	Time			
			<b>Speed</b>			
	Pan/Tilt EMS	<b>On, Off</b>				
	Follow Spot Mode	<b>Off</b>				
		Soft				
		Medium				
		Hard				
	Microphone Sensitivity	1-10-20				
	Blackout Settings	Blackout During M.C.	<b>Off, On</b>			
		Blackout while:	Pan/Tilt moving	<b>Off, On</b>		
			Colour Wheel Moving	<b>Off, On</b>		
			TimeOut Blackout	<b>Off, On</b>		
	Init Effect Positions	Pan	0-255			
		:				
		Dimmer Fine	0-255			
	Screen Settings	Display Intensity	1-10			
		Screen Saver Delay	<b>Off-10min.</b>			
		Touchscreen Lock	<b>Off-10min.</b>			
		Recalibrate Touchscreen				
		Display Orientation	Normal			
			Inverted			
			<b>Auto</b>			
	Temperature Unit	°C, °F				
	Fan Mode	<b>Auto</b>				
		High				
	Dimmer Curve	Linear				
		<b>Square Law</b>				
	Date & Time Settings					

Tab	Level 1	Level 2	Level 3	Level 4	Level 5	Level 6
	Password Protection	Off, On				
Manual Control	Reset Functions	Total System Reset				
		Pan, Tilt reset				
		Colour System Reset				
		Gobo System Reset				
		Dimmer, Strobe Reset				
		Optics, Prism, Frost Res.				
		Iris, Fr. Sh. Eff. Wh Reset				
	Manual Effect Control	Pan	0-255			
		:				
		Dimmer Fine	0-255			
Stand -Alone	Test Sequences	Dynamic Mode				
		Static Mode	Pan	0-255		
			Tilt	0-255		
			Zoom	0-255		
			Focus	0-255		
	MusicTrigger	Off, On				
	Preset Playback	None				
		Test				
		Prg. 1				
		Prg. 2				
		Prg. 3				
	Play Program	Play Program 1				
		Play Program 2				
		Play Program 3				
	Edit Program	Edit Program 1	Start Step	1-100		
			End Step	1-100		
			Edit Program Steps	Step 1	Pan	0-255
				:	:	
				:	Dimmer Fine	0-255
				:	Step Time	0-25,5 sec.
				Step 100	Pan	0-255
					:	
					Dimmer Fine	0-255
					Step Time	0-25,5 sec.
Service	Adjust DMX Values	Pan	0-255			
		:				
		Dimmer Fine	0-255			
	Adjust Lamp	Pan	0-255			
		:				
		Focus	0-255			
	Calibrations	Calibrate Effects	Pan	0-255		
			:			
			Fr. Shutter 4 Swiv.	0-255		
		Calibrate Pan/Tilt EMS.				
		Load Default Calibrations				
	Update Software					

## 7. Control menu

The Robin BMFL Blade is equipped with the QVGA Robe touch screen with battery backup which allows to set the fixture's behaviour according to your needs, obtain information on its operation, test its various parts and lastly program it, if it has to be used in a stand-alone mode. The fixture's menu can be controlled either by the control buttons or directly by touching the icon.

### Control buttons on the front panel:

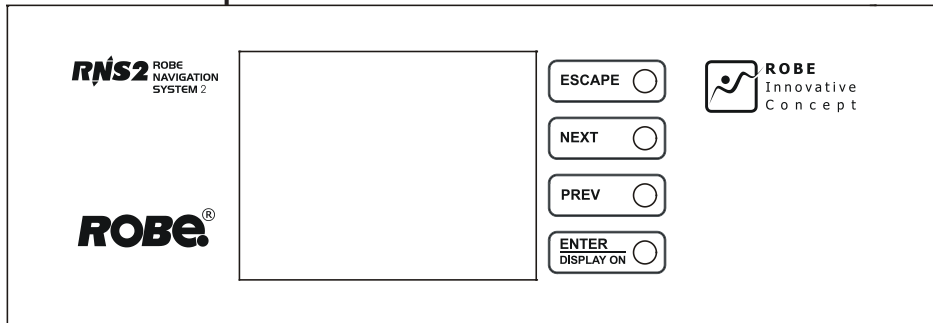

[ESCAPE] button used to leave the menu without saving changes.

[NEXT] , [PREV] buttons for moving between menu items and symbols, adjusting values.

[ENTER/Display On] button used to enter the selected menu (menu item) and to confirm adjusted value.

**If the fixture is disconnected from mains, the button switches the touch screen on.**

### Icons used in the touch screen menu:



- [back arrow] used to move back to the previous screen (menu).



- [up arrow] used to move up on the previous page.



- [down arrow] used to move down on the next page.



- [confirm] used to save adjusted values, to leave menu or to perform desired action.



- [cancel] used to leave menu item without saving changes.



- [confirm+copy] used to save adjusted values and copy them to the next prog. step.



- [warning icon] used to indicate some error which has occurred in the fixture.



- [lamp menu] used to switch on/off the lamp and to set lamp functions.



- [Ethernet] used to indicate Ethernet connected.



- [menu rotation] used to rotate menu 180 degrees from current orientation.



- [slider control] used to recall slider system for setting desired value.



- [keyboard control] used to recall keyboard system for setting desired value.



- [air filters cleaning] used to signal that cleaning period of the air filters elapsed.



- [250 hours remain] used to signal that 250 hours remain to change the lamp.



- [50 hours remain] used to signal that 50 hours remain to change the lamp.

The menu page displays icons for each function that you can perform from the touch screen.

The menu page displays icons for each function that you can perform from the touch screen.

After switching the fixture on, the touch screen shows the screen with the ROBE logo:

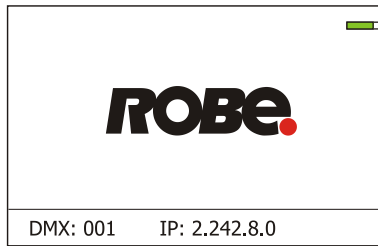

Note: The green icon at the top right corner of the screen indicates the level of the display battery charging. If the whole icon is green, the battery is fully charged while the red icon indicates exhausted battery. The battery charges during fixture operation, its charging lasts cca 6 hours.

We recommend that the fixture should be in operation at least 7 hours per week to keep the battery fully charged. If you switch the fixture on and this screen will not appear till 1 minute, switch the fixture off and on again. If the screen lights, the battery is exhausted. In case the screen still does not light, the battery is faulty.

This is also indicated by an error message "Faulty battery" and if such an error message appears the battery should be replaced immediately. The lifetime of the battery is highly dependent on ambient temperature (and consequently on base temperature). If the maximum ambient temperatures (as recorded and displayed in menu: Information -> Fixture Temperatures -> Ambient Temperature -> Maximum NonRes.) are kept within the specified limits, the battery should last for at least two years. Should the ambient temperatures exceed the specified maximum temperature, the lifetime of the batteries could be considerably shortened even up to just one year or less and also result in physical damage (battery leakage) or unreliable fixture functions.

Damage caused by batteries failed due to exceeded maximum ambient temperature cannot be claimed under warranty terms.

Touch any part of the screen or press the [ENTER/Display On] button to display the initial screen with the current stored DMX address (and the end address for selected DMX mode):

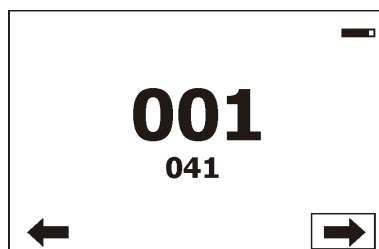

Touch the green arrow at the bottom right corner of the screen or press the [ENTER/Display On] button to enter the "Address" menu.

An item (such as a Tab, menu item, text box, icon) may be selected from a screen by simply touching the item.

**Before first fixture operation, set current date and time in the menu "Date & Time Settings" (menu path: Personality--> Date & Time Settings).**

## 7.1 Tab "Address"



**DMX Address** - Select the menu to set the DMX start address.

**DMX Preset** - Use the menu to select desired channel mode.

**Mode 1** - 49 control channels

**Mode 2** - 42 control channels

**View Selected Preset** - Use the menu to display channels included in the selected mode.

**Ethernet Settings** - The menu allows all needed settings for the Ethernet operation

## **Ethernet Mode**

**Disable** - The option disables Ethernet operation.

**Artnet** - Fixture receives Artnet protocol

**gMA1** - Fixture receives MANet 1 protocol

**gMA2** - Fixture receives MANet 2 protocol

**sACN** - Fixture receives sACN protocol

**Ethernet To DMX** - Fixture receives protocol from the Ethernet input and sends DMX data to its DMX output (fixture works as an "Ethernet/DMX converter", next fixture can be connected to its DMX output and you can build a standard DMX chain by connecting another fixtures. Only one fixture has to be connected to the Ethernet.

**IP Address/Net Mask** - Select this menu to set IP address. IP address is the Internet protocol address. The IP uniquely identifies any node (fixture) on a network. There cannot be 2 fixtures with the same IP address on the network!

**Default IP Address** - Preset IP address, you can set up only first byte of IP address (2 or 10) e.g. 002.019.052.086.

**Custom IP Address** - The option enables to set up all bytes of IP address.

**Net Mask** - The option enables to set up all bytes of Net Mask.

**ArtNet Universe** - Use this item to set a Universe (0-255). The Universe is a single DMX 512 frame of 512 channels.

**MANet Settings** - Use this menu to set parameters for MANet operation.

**MANet Universe I/II** - The value of this item can be set in range 1-256.

**MANet Session ID** - The value of this item can be set in range 1-32.

**sACN Settings** - Use this menu to set parameters for sACN operation.

**sACN Universe** - The value of this item can be set in range 1-32000.

**sACN Priority** - The value of this item can be set in range 0-255.

## **7.2 Tab "Information"**



**Fixture Times** - The menu provides readouts of fixture and lamp operation hours.

**Power On Time Hours** - Select this menu to read the number of fixture operation hours.

**Total Hours** - The item shows the total number of the operation hours since the Robin BMFL Blade has been fabricated.

**Resetable Hours** - The item shows the number of the operation hours that the Robin BMFL Blade has been powered on since the counter was last reset.

In order to reset this counter to 0, touch the text box next to the item "Resetable Hours:"

**Lamp On Time Hours** - Select this menu to read the number of hours of lamp operation.

**Total Hours** - The item shows the total number of the lamp operation hours since the Robin BMFL Blade has been fabricated.

**Remaining Hours** - The item shows hours remaining to replacement of the lamp. The initial value for this counter is 750 hours. In order to reset this counter to 750, touch the text box next to the item "Remaining Hours:"

**Lamp Strikes** - Select this menu to read the number of lamp strikes.

**Total Strikes** - The item shows the total number of the lamp strikes since the Robin BMFL Blade has been fabricated.

**Resetable Strikes** - The item shows the number of the lamp strikes since the counter was last reset.

In order to reset this counter to 0, touch the text box next to the item "Resetable Strikes:".

When zero is reached, counter continues to negative values and the Red lamp icon is displayed

**Air Filters** - Regular cleaning of the air filters is very important for the fixture's life and performance. Build-up of dust, dirt and fog fluid residues reduces the fixture's light output and cooling ability.



The two items of this menu help you to keep cleaning period of the air filters.

**Alert period** - Cleaning schedule for the fixture depends on the operating environment. It is therefore impossible to specify accurate cleaning interval. This item allows you to change the cleaning interval of the air filters. This "alert" value is 300 hours and it is set as default. Inspect the fixture within its 300 hours of operation to see whether cleaning is necessary. If cleaning is required, clean all air filters and change the value in this menu on acceptable level. Min. level of alert period is 10 hours, max. is 300 hours.

**Elapsed Time** - The item allows you to read the time which remains to cleaning air filters. The time period is set in the menu mentioned above.

Expired time period is signalled by a negative mark (-) at the time value and a warning icon on the display.

Clean the filters and reset this menu item (by touching the text box next to the item "Elapsed Time").

**Fixture Temperatures** - The menu is used to view temperatures of the fixture's inside.

**Head Temperature** - The menu shows temperatures in the fixture head near the lamp.

**Current** - A current temperature of the fixture head.

**Maximum NonRes.** - A maximum temperature of the fixture head since the fixture has been fabricated.

**Maximum Res.** - A maximum temperature of the fixture head since the counter was last reset.

In order to reset this counter to 0, touch the text box next to the item "Maximum Res."

**Note:** if the "Head Temperature" exceeds 115°C, the lamp will be switched off.

**Base Temperature** - The menu shows temperature in the fixture base (on the display PCB).

**Current** - A current temperature in the fixture base.

**Maximum NonRes.** - A maximum temperature in the fixture base since the fixture has been fabricated.

**Maximum Res.** - A maximum temperature in the fixture base since the counter was last reset.

In order to reset this counter to 0, touch the text box next to the item "Maximum Res."

**Ambient Temperature** - The menu shows temperature of the induced air on the fan in the fixture base .

**Current** - A current temperature of the induced air in the fixture base.

**Maximum NonRes.** - A maximum temperature of the induced air in the fixture base since the fixture has been fabricated.

**Maximum Res.** - A maximum temperature of the induced air in the fixture base since since the counter was last reset.

In order to reset this counter to 0, touch the text box next to the item "Maximum Res."

**DMX Values** - The menu is used to read DMX values of each channel received by the fixture.

**Wireless State** - The menu serves for reading of the wireless operation status

**Unlink Wireless Adapter** - The menu item allows unlinking the fixture from the transmitter .

**Power Channel State** - The menu item shows state of the Power/Special functions switches.

**Software Version** - Select this item to read the software version of the fixture modules:

**Display System** - A display processor on the display board in the fixture base

**Module M** - A pan/Tilt

**Module G** - A rot. gobo wheel, effect wheel position/ rotation, static gobo wheel

**Module P** - A prism, frost

**Module O** - A zoom, focus

**Module C** - A CMY+CTO module

**Module D** - A dimmer, lamp fans

**Module S** - A shutter, colour 1 and colour 2

**Module FA** - A framing lamella 1/2, iris

**Module S** - A framing lamella 3/4, framing module rotation

**Product IDs** - The menu is used to read the MAC Address ,RDM UID and RDM Label.

**View Logs** - Use this menu to read fixture's data which have been recorded during fixture operation. This collected data allows easier troubleshooting.

**Fixture Errors** - Use this menu to read fixture errors which have occurred during fixture operation.

There is a list of error messages:

Pan Error  
Tilt Error  
Dimmer 1 Error  
Dimmer 2 Error  
Colour Error  
Yellow Error  
Gobo Error  
Gobo Carousel Error  
Static Gobo Error  
Focus Error  
Zoom Error  
Base Overheated

Prism Error  
Prism Rotation Error  
Frost Error  
Cyan Error  
Magenta Error  
CTO Error  
Clean Air Filters  
Iris Error  
Active Lamp Timer  
Lamp Error  
Temp. Sensor Error

**Fixture States** - Recorded following actions: Fixture On, Fixture Off, Lamp On, Lamp Off.

**Fixture Position** - Recorded installation positions of the fixture:

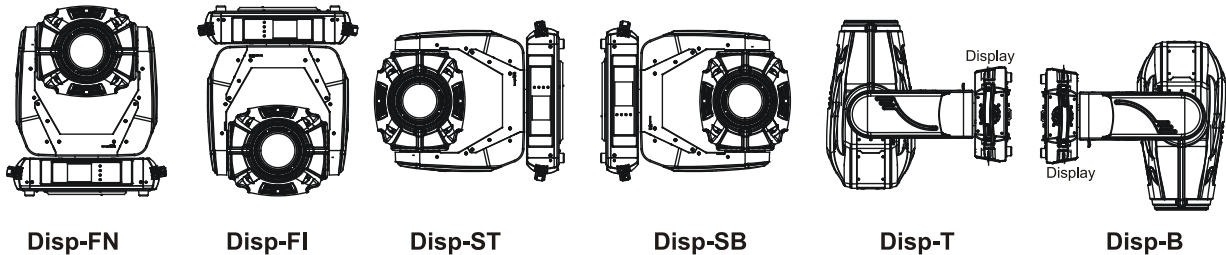

**Fixture Temperatures** - Recorded temperatures which have exceeded defined levels.

Note: The log buffer can contain 8000 records max. If the buffer is full, old data will be overwritten.

## 7.3 Tab "Personality"



**User mode** - The Robin BMFL Blade allows you to recall two user settings. After switching the fixture on for the first time, the User A settings is active. Now all changes made in the "Personality" menu , "Addressing" menu and the "Music Trigger" and "Preset Playback" items from the "Stand-alone" menu are saved to the User A settings. If you now select the User B settings, from this moment the changes made in these menus will be saved to the User B settings. After switching the fixture off and on, the User B setting is active.

**User A Settings** - the function recalls the user A settings.

**User B Settings** - the function recalls the user B settings.

**DMX Preset** - Use the menu to select desired channel mode.

**Mode 1** - 49 control channels

**Mode 2** - 42 control channels

**View Selected Preset** - Use the menu to display channels included in the selected mode.

**DMX Input**- Use the menu to select mode of receiving DMX signal.

**Wired** - DMX signal is received by means of the standard DMX cable.

**Wireless** - DMX signal is received by means of the inbuilt wireless module.

**Wireless In/XLR Out**- the fixture receives wireless DMX and sends the signal to its wired DMX output.

The fixture behaves as " Wireless/Wired" adapter.

The options "Wired" and "Wireless" are also stated in DMX chart (channel Power/Special functions).

**Pan/Tilt Settings** - Use the menu set behaviour of both pan and tilt movements.

**Pan Reverse** - The item allows to invert pan movement.

**Tilt Reverse** - The item allows to invert tilt movement.

**Pan/Tilt Feedback** - The item allows to return the moving head to the required pan/tilt position after changing the position by an external force if this option is set on.

Note. Be careful, the Pan/Tilt Feedback should be permanent On, the option Off is not suitable for standard operation and the head of the fixture can be damaged!

**Pan/Tilt mode** - Use this menu to set the mode of the pan/tilt movement

**Time mode** – The pan and tilt will move with different speeds and they will come at

the same time to the end point of their tracks (pan and tilt use their optimal speeds). Time of the pan/tilt movement (25.5 sec. max.) is set by the channel "Pan/Tilt speed, Pan/Tilt time".

**Speed Mode** - Both Pan and tilt will move with the same speed as adjusted at the channel "Pan/Tilt speed, Pan/Tilt time".

**Pan/Tilt EMS** - Built-in electronic motion stabilizer ensures precise position of the fixture's head during its movement and also reducing its swinging when the truss shakes.

**Follow Spot Mode** - If the function is activated, the pan/tilt motors perform on lower power and the head position can be controlled manually. You can choose from three levels of the pan/tilt "consistency": soft, medium and hard. Note: reset of pan/tilt will not be executed if the fixture is in the Follow Spot Mode.

**Microphone Sensitivity** - Enter the menu if you want to adjust the microphone sensitivity from 1 (max.) to 20 (min.).

**Blackout Settings** - Use the menu if you need to close the light output under certain conditions which are described below

**Blackout DMC** - Blackout during movement correction. Set this option On if you wish to close light output during the time when the head goes to its correct position, which has been changed by an external force.

**Active Blackouts** - Use this menu if you wish to close the light output during effect changes.

**Pan/Tilt Moving** - The menu item enables to close light output while the pan/tilt coordinates are changing.

**Colour Wheel Moving** - The menu item enables to close light output while the colour wheel is moving.

Note: Due to the fast movement of the colour wheels, the function "Active Blackouts" is used at movement on longer distances correctly. When you move the colour to the adjacent position, blackout cannot be made so fast.

**Timeout Blackout** - If this function is On, two framing lamellas close on expiration 5 seconds after that the dimmer was closed in order to totally close light output from the fixture.

**Init Effect Positions** - Use the menu to set all effects to the desired positions at which they will stay after switching the fixture on without DMX signal connected.

**Screen Settings** - Use this menu to change the touch screen settings.

**Display Intensity** - The item allows to control the intensity of the screen (1-min., 10-max.).

**Screen saver Delay** - The item allows you to keep the screen on or to turn it off automatically after 1-10 minutes after last touch (or pressing any button on the control panel).

**Touchscreen Lock** - The item allows you to lock the screen after last touch (or pressing any button on the control panel). The time delay can be set in range of 1-10 minutes. To unlock the screen, press the [ENTER/Display On] button.

**Recalibrate Touchscreen** - The item starts calibration of the touchscreen. Follow the instructions on the screen.

**Display Orientation** - The menu allows to change display orientation.

**Normal** - Standard display orientation if the fixture is placed horizontally (e.g. on the ground).

**Inverted** - Inverted orientation (needed if the fixture is hanging on the truss).

**Auto** - The option activates a gravitation sensor for automatic screen orientation.

Note: **Auto** option is set as default. You change the display orientation by touching the icon  on the display, and the option set in the "Display Orientation" menu is temporarily overridden.

**Temperature unit** - Use the menu item to change temperature unit from °C to °F.

**Fan Mode** - Use the menu to set the fixture fans to max. power mode ("**High**") or to auto-control mode ("**Auto**").

**Dimmer Curve** - You can select desired dimmer curve: Linear or Square Law.

**Date & Time Settings** - Use this menu to set current date and time for the fixture log system (menu "**View Logs**"). Set this menu item before first fixture operation.

**Default Settings** - The menu item allows to set all fixture parameters to the default (factory) values.

**Password Protection** - if the item is on, a password is required to enter the fixture menu. The password cannot be changed. The password prevents unauthorized person from changing setting of the fixture.

## 7.4 Tab "Manual Control"



**Reset Functions** - The menu allows to reset the fixture either per function modules or all modules together.

**Total System Reset** - The item resets all function modules.

**Pan,Tilt Reset** - The item resets a pan and tilt movement (except Follow Spot Mode).

**Colour System Reset** - The item resets a colour wheels and CMY/CTO flags.

**Gobo System Reset** - The item resets rotating gobo wheels.

**Dimmer, Strobe Reset** - The item resets strobe and shutter lamellas .

**Optics,Prism,Frost Reset** - The item resets a zoom, focus, prism and a frost module.

**Iris,Fr. Sh., Eff. wh Reset** - The item resets an iris, effect wheel and framing shutters.

**Manual Effect control** - Use the menu to control all fixture channels by means of the control panel.

## 7.5 Tab "Stand-alone"



**Test Sequences** -Use the menu to run a test/demo sequences without an external controller, which will show you some possibilities of using Robin BMFL Blade.

**Dynamic Mode** - This mode uses all Robin BMFL Blade functions including pan/tilt movement and therefore is good for a complete introduction of the fixture.

**Static Mode** - This mode is suitable for projections on the wall, ceiling or ground without any pan/tilt movement. Adjust the pan, tilt, zoom, focus and hot-spot to desired positions and start test sequences by touching the green ► icon.

**Music Trigger** - Use the item to activate the sound control of the running program via the built-in microphone.

**Preset Playback** - This menu allows you to select the program which will be played in a loop after switching the fixture on (the option is commonly used in a stand-alone operation without an external controller).

**None** - The option disables "Presetting playback" function.

**Test** - The option starts the test sequences.

**Prog. 1** - The option starts user program No. 1.

**Prog. 2** - The option starts user program No. 2.

**Prog. 3** - The option starts user program No. 3.

**Play program** - Use the menu to run desired program in a loop.

**Play Program 1** - The option starts user program No.1.

**Play Program 2** - The option starts user program No. 2.

**Play Program 3** - The option starts user program No. 3.

**Edit Program** - Use the menu to create or to edit desired program. The Robin BMFL Blade offers 3 free programs, each up to 100 steps.

**Edit Program 1** - The option allows to edit user program No.1.

**Edit Program 2** - The option allows to edit user program No.2.

**Edit Program 3** - The option allows to edit user program No.3

To edit program:

1. Touch the item which you want to edit ("Edit Program 1" - "Edit Program 3").

2. Touch the item "Edit Program Steps".

3. Touch the item "Step 1".

4. From the list of effects touch desired effect and set its value. Browse through the list by touching the [up arrow] and [down arrow] and set all desired effects.

An item "Step Time" (value of 0-25.5 sec.) is the time during which effects last in the current step

5. Save adjusted effects to the current step by touching the [confirm] or save and copy them to the following step by touching the [confirm+copy]. By touching the text box "Preview" next to the current program step you can view created scene.

6. Repeat the steps 4 and 5 for next program steps.

7. After editing desired program steps, adjust the length of the program by touching the text boxes "Start Step"

and "End Step".

Meaning of the icons used in the "Edit Program" menu:

- ↓ - moves down on the next page
- ↑ - moves up on the previous page
- ✓ - saves adjusted values and leaves menu
- ✓ - saves values to the current step and copy them to the following prog. step

✗ - leaves menu without saving values

There is a chart describing behaviour of items "Pan/Tilt Macro" and "P./T. Macro Speed".

<b>DMX</b>	<b>Pan/Tilt Macro</b>
0 - 9	Disabled pan/tilt macro
10 - 31	Reserved
32 - 63	Figure of circle (from small to large)
64 - 95	Figure of horizontal eight (from small to large)
96 - 127	Figure of vertical eight (from small to large)
128 - 159	Figure of rectangle (from small to large)
160 - 191	Figure of triangle (from small to large)
192 - 223	Figure of star (from small to large)
224 - 255	Figure of cross (from small to large)
	<b>Pan/Tilt Macro Speed</b>
0	No macro generation
	Macro generation from fast to slow-forwards
	No macro generation
	Macro generation from slow to fast-backwards

## 7.6 Tab "Service"



**Adjust DMX Values** - The menu allows you to set all effects to desired positions before fine calibration of the effects .

**Adjust Lamp** - This item opens the light output of the fixture and enables to focus the light beam on the wall to perform the fine lamp adjustment.

**Calibrations** - This menu enables fine calibration of fixture effects and download default calibration values.

**Calibrate Effects** - The menu allows the fine adjustment of effects. The menu contains list of effects which can be calibrated:

- Pan** - a fine pan movement
- Tilt** - a fine tilt movement
- Colour Wheel 1** - a colour wheel 1
- Colour Wheel 2** - a colour wheel 2
- Cyan** - cyan flags
- Magenta** - magenta flags
- Yellow** - yellow flags
- CTO** - CTO flags
- Effect Wheel** - an effect wheel
- Static gobo** - a static gobo wheel
- Rot. Gobo Wheel** - a carousel of rotating gobos
- R. Gobo Index 1** - a fine movement of rotating gobo 1
- R. Gobo Index 2** - a fine movement of rotating gobo 2
- R. Gobo Index 3** - a fine movement of rotating gobo 3
- R. Gobo Index 4** - a fine movement of rotating gobo 4
- R. Gobo Index 5** - a fine movement of rotating gobo 5
- R. Gobo Index 6** - a fine movement of rotating gobo 6
- Prism 1** - a 6-facet radial prism
- Prism 1 Rot** - a 6-facet radial prism rotation
- Prism 2** - a 6-facet axial prism
- Zoom** - a zoom position
- Frost 1/1** - a light frost position 1

**Frost 1/2** - a light frost position 2  
**Frost 2/1** - a medium frost position 1  
**Frost 1/2** - a medium frost position 2  
**Focus 1** - a focus position 1  
**Focus 2** - a focus position 2  
**Iris** - an iris  
**Strobe 1/1** - a strobe lamella 1 position 1  
**Strobe 1/2** - a strobe lamella 1 position 2  
**Strobe 2/1** - a strobe lamella 2 position 1  
**Strobe 2/2** - a strobe lamella 2 position 2  
**Dimmer 1/1** - a dimmer lamella 1 position 1  
**Dimmer 1/2** - a dimmer lamella 1 position 2  
**Dimmer 2/1** - a dimmer lamella 2 position 1  
**Dimmer 2/1** - a dimmer lamella 2 position 2  
**Diffusor** - auxiliary optic element  
**Fr. Shutters Rot.** - a rotation of framing carousel  
**Fr. Reset 1 M1** - a Fram. lamella 1 motor 1 - distance from stop  
**Fr. Reset 1 M2** - a Fram. lamella 1 motor 2- distance from stop  
**Fr. Reset 2 M1** - a Fram. lamella 2 motor 1 - distance from stop  
**Fr. Reset 2 M2** - a Fram. lamella 2 motor 2 - distance from stop  
**Fr. Reset 3 M1** - a Fram. lamella 3 motor 1 - distance from stop  
**Fr. Reset 3 M2** - a Fram. lamella 3 motor 2 - distance from stop  
**Fr. Reset 4 M1** - a Fram. lamella 4 motor 1 - distance from stop  
**Fr. Reset 4 M2** - a Fram. lamella 4 motor 2 - distance from stop  
**Fr. Shutter 1 Mov.** - a Fram. lamella 1 moving  
**Fr. Shutter 1 Swiv.** - a Fram. lamella 1 swivelling  
**Fr. Shutter 2 Mov.** - a Fram. lamella 2 moving  
**Fr. Shutter 2 Swiv.** - a Fram. lamella 2 swivelling  
**Fr. Shutter 3 Mov.** - a Fram. lamella 3 moving  
**Fr. Shutter 3 Swiv.** - a Fram. lamella 3 swivelling  
**Fr. Shutter 4 Mov.** - a Fram. lamella 4 moving  
**Fr. Shutter 4 Swiv.** - a Fram. lamella 4 swivelling

By using these items you can calibrate and adjust effects to their right positions.

#### Calibration via the control board

1. Disconnect DMX controller from the fixture and enter the "Calibrate Effects" menu.
2. Use the [up arrow] and [down arrow] to find desired effect and touch it to enter the fine effect adjustment screen.
3. Set desired value and save it by touching the [confirm].
4. Repeat steps 2 and 3 for the next effects.
5. After calibrating all effects, touch the [confirm] to save all adjusted values and reset the fixture.

#### Calibration via the DMX controller

1. Connect DMX controller to the fixture and set fixture effects to the desired positions before fine calibration.
  2. Enter the "Calibrate Effects" menu and now you can exactly calibrate desired effects by DMX controller.
- A calibration protocol:

Effect	Mode 1	Mode 2
Pan	channel 50	channel 43
Tilt	channel 51	channel 44
Colour Wheel 1	channel 52	channel 45
Colour Wheel 2	channel 53	channel 46
Cyan	channel 54	channel 47
Magenta	channel 55	channel 48
Yellow	channel 56	channel 49
CTO	channel 57	channel 50
Effect wheel	channel 58	channel 51
Static gobo	channel 59	channel 52
Rot. Gobo Wheel	channel 60	channel 53
R. Gobo Index 1	channel 61	channel 54
R. Gobo Index 2	channel 62	channel 55
R. Gobo Index 3	channel 63	channel 56

R. Gobo Index 4	channel 64	channel 57
R. Gobo Index 5	channel 65	channel 58
R. Gobo Index 6	channel 66	channel 59
Prism 1	channel 67	channel 60
Prism 1 Rot	channel 68	channel 61
Prism 2	channel 69	channel 62
Zoom	channel 70	channel 63
Frost 1/1	channel 71	channel 64
Frost 1/2	channel 72	channel 65
Frost 2/1	channel 73	channel 66
Frost 2/2	channel 74	channel 67
Focus 1	channel 75	channel 68
Focus 2	channel 76	channel 69
Iris	channel 77	channel 70
Strobe 1/1	channel 78	channel 71
Strobe 1/2	channel 79	channel 72
Strobe 2/1	channel 80	channel 73
Strobe 2/2	channel 81	channel 74
Dimmer 1/1	channel 82	channel 75
Dimmer 1/2	channel 83	channel 76
Dimmer 2/1	channel 84	channel 77
Dimmer 2/1	channel 85	channel 78
Diffusor	channel 86	channel 79
Fr. Shutters Rot.	channel 87	channel 80
Fr. Reset 1 M1	channel 88	channel 81
Fr. Reset 1 M2	channel 89	channel 82
Fr. Reset 2 M1	channel 90	channel 83
Fr. Reset 2 M2	channel 91	channel 84
Fr. Reset 3 M1	channel 92	channel 85
Fr. Reset 3 M2	channel 93	channel 86
Fr. Reset 4 M1	channel 94	channel 87
Fr. Reset 4 M2	channel 95	channel 88
Fr. Shutter 1 Mov.	channel 96	channel 89
Fr. Shutter 1 Swiv.	channel 97	channel 90
Fr. Shutter 2 Mov.	channel 98	channel 91
Fr. Shutter 2 Swiv.	channel 99	channel 92
Fr. Shutter 3 Mov.	channel 100	channel 93
Fr. Shutter 3 Swiv.	channel 101	channel 94
Fr. Shutter 4 Mov.	channel 102	channel 95
Fr. Shutter 4 Swiv.	channel 103	channel 96

After having calibrated all effects, touch the [confirm] to save adjusted values and reset the fixture.

**Load Default Calibrations** - The item loads default (factory) calibration values.

**Calibrate Pan/Tilt EMS** - This menu item allows calibration of the pan/tilt electronic motion stabilizer.  
Important: during this calibration any external force must not influence the fixture and the surface at which the fixture stands (or truss if the fixture hangs) has to be without movement, shake, strokes etc.

**Updating software** - The menu item allows you to update software in the fixture via either serial or USB port of PC.

The following are required in order to update software:

- PC running Windows 95/98/2000/XP/7/8 or Linux
- DMX Software Uploader
- Flash cable RS232/DMX No.13050624 (if you want to use a serial port of PC)
- Robe Universal Interface (if you want to use an USB port of PC)

Note: Software update should execute a qualified person. If you lack qualification, do not attempt the update yourself and ask for help your ROBE distributor.

DMX address, IP address, programs 1-3 and all items in the menu "Personality" will be set to their default (factory) values.

**To update software in the fixture:**

I. Installation of the DMX Software Uploader.

1. DMX Software Uploader program is available from the ROBE web site at [WWW.robe.cz](http://WWW.robe.cz).
2. Make a new directory ( e.g. Robe\_Uploader) on your hard disk and download the software to it.

3. Unpack the software.

## II. Fixture software updating.

1. Determine which of your ports is available on your PC and connect it:

- with the DMX input of the fixture if you using the flash cable RS232/DMX
- with the DMX output of the Robe Universal Interface if you using the USB cable.

Disconnect the fixture from the other fixtures in a DMX chain. Turn both the computer and the fixture on. Make sure the lamp is switched off (only if the fixture involves a lamp).

2. Switch the fixture to the updating mode by touching the "Updating Software " item

Note: If you do not want to continue in software update, you have to switch off and on the fixture to escape from this menu.

We recommend to cancel all running programs before starting the Software Uploader.

3. Run the Software Uploader program. Select desired COM and then click on the Connect button. (Select COM if the serial port is used or Robe Universal Interface if the USB port is used).

If the connection is OK, click on the "Start Uploading button" to start uploading. It will take several minutes to perform software update.

If the option "Incremental Update" is not checked, all processors will be updated (including processors with the same software version).

If you wish to update only later versions of processors, check the "Incremental Update box".

Avoid interrupting the process. Update status is being displayed in the Info Box window.

When the update is finished, the line with the text "The fixture is successfully updated" will appear in this window and the fixture will reset with the new software.

Note: In the case of an interruption of the upload process (e.g. power cut), the fixture keeps the updating mode and you have to repeat the software update again.

## 7.7 Icon "Lamp menu"



**Lamp Status** - The item enables to switch the lamp on/off. The Osram Lok-it! HTI 1700/PS lamp is a cold restrike type, that means, that it has to be cold before striking.

**Settings** - The menu offers many items for setting of lamp behaviour.

**Lamp Power** - The menu offers two levels of the lamp power: 1700W, 1500W and the option Quiet, at which the lamp power is auto-controlled to ensure minimum noise of the fixture fans.

All these options are available at DMX channel 6. The factory setting is 1700W.

**Lamp Ignition Delay** - The item allows to set the time delay( 0-90sec.) before igniting the lamp by DMX command. If the lamp is started directly from the control panel, the set time delay will be ignored.

**Lamp Light Sensor** - Select this item to switch the light sensor off. The option "On" is intended for a standard operation. The option "Off" is for "emergency operation" only! If the lamp light sensor is switched off, the fixture will still try to ignite the lamp (even when the lamp is damaged or absent), on this account some electronics parts of the fixture can be damaged!

**Lamp On/Off Settings** - Use the menu to set rules for automatic switching on/off the lamp.

**Lamp On Power On** - If the item is on, the lamp will be automatically turn on after switching the fixture on.

**Lamp Off via DMX** - The item enables to switch the lamp off via DMX command from DMX controller.

**Lamp On if DMX Present** - The item allows you to strike the lamp automatically after 26 seconds if DMX signal is present on the fixture's DMX input.

**Lamp Off if not DMX** - The item allows you to switch off the lamp automatically after 2 minutes if DMX signal is missing on the fixture's DMX input.

## 8. RDM

This fixture supports RDM operation. RDM (Remote Device Management) is a bi-directional communications protocol for use in DMX512 control systems, it is the new open standard for DMX512 device configuration and status monitoring.

The RDM protocol allows data packets to be inserted into a DMX512 data stream without adversely affecting



existing non-RDM equipment. By using a special „Start Code,“ and by complying with the timing specifications for DMX512, the RDM protocol allows a console or dedicated RDM controller to send commands to and receive messages from specific moving lights.

RDM allows explicit commands to be sent to a device and responses to be received from it.

The list of commands for Robin BMFL Blade is the following.

Parameter ID	Discovery command	SET command	GET command
DISC_UNIQUE_BRANCH	*		
DISC_MUTE	*		
DISC_UN_MUTE	*		
DEVICE_INFO			*
SUPPORTED_PARAMETERS			*
SOFTWARE_VERSION_LABEL			*
DMX_START_ADDRESS		*	*
IDENTIFY_DEVICE		*	*
DEVICE_MODEL_DESCRIPTION			*
MANUFACTURER_LABEL			*
DEVICE_LABEL		*	*
SENSOR_DEFINITION			*
SENSOR_VALUE			*
DISPLAY_INVERT		*	*
DISPLAY_LEVEL		*	*
PAN_INVERT		*	*
TILT_INVERT		*	*
DEVICE_RESET		*	
DMX_PERSONALITY		*	*
DMX_PERSONALITY_DESCRIPTION			*
STATUS_MESSAGES			*
STATUS_ID_DESCRIPTION			*
LAMP_STATE		*	*
LAMP_ON_MODE <sup>1</sup>		*	*
DEVICE_HOURS <sup>2</sup>			*
LAMP_HOURS <sup>2</sup>			*
LAMP_STRIKES <sup>2</sup>			*
ROBE_DMX_INPUT		*	*
ROBE_WIRELESS_UNLINK		*	

<sup>1</sup>...Another options for this command (only for Robe's fixtures):

value PARAMETER\_DATA=0x84 - lamp OFF by DMX value on DMX channel

value PARAMETER\_DATA=0x88 - lamp OFF if DMX is not present

<sup>2</sup>...Commands relative resetable values

## 9. Wireless DMX operation

The wireless version of the Robin BMFL Blade is equipped with the Lumen Radio CRMX module and antenna for receiving DMX signal. CRMX module operates on the 2.4 GHz band.

The item " Wireless " from the menu "DMX Input" allows you to activate receiving of wireless DMX (Personality--> DMX Input -->Wireless.). First two options from the "DMX Input" menu are stated in DMX chart as well (channel Power/Special functions , range of 10-19 DMX). If DMX input option is changed by DMX command, the change is permanently written into fixture's memory.

**DMX range of 10-19 switching fixture to the wired/wireless operation is active only during first 10 seconds after switching the fixture on.**

After switching the fixture on, the fixture checks both modes of receiving DMX in the following order:

1. For the first five seconds, the fixture receives DMX signal from the wired input. If the Power/Special functions channel is set at some DMX input option, the fixture will receive DMX value according to this option. If DMX input option is set to the wired input, this option is saved and checking procedure is finished. If DMX input option is not set, the fixture continues next 5 seconds in scanning wireless DMX signal-see point 2.
2. For the next 5 seconds the fixture receives wireless DMX signal and again detects if the Power/Special functions channel is set at some DMX input option, if not, the fixture will take option which is set in the fixture menu "DMX Input".

To link the fixture with DMX transmitter.

The fixture can be only linked with the transmitter by running the link procedure at DMX transmitter . After linking , the level of DMX signal ( 0-100 %) is displayed in the menu item "Wireless State" (Information -->Wireless State).

To unlink the fixture from DMX transmitter.

The fixture can be unlinked from receiver via the menu item " Unlink Wireless Adapter" (Information--> Wireless State --> Unlink Wireless Adapter).

## 10. Error and information messages

### Information icons



#### - Air Filters Cleaning

This icon signals that cleaning period of the air filters has elapsed and you have to clear air filters and reset the menu item "Elapsed Time".

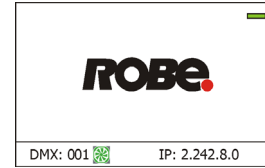

#### - Lamp time - 250 hours remaining

This icon signals that 250 hours remain before replacing the lamp.

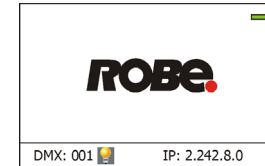

#### - Lamp time - 50 hours remaining

This icon signals that 50 hours remain before replacing the lamp.

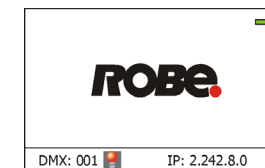

### Errors

Error in the fixture is signalled by the yellow warning icon at the bottom line of the screen:



Touch the warning icon or press the [ESCAPE] button to display error messages.  
List of error and information messages:

#### Active Lamp Timer

This message appears if you try to switch on the hot lamp. The fixture tries to ignite the lamp and during time period before next attempt of the lamp ignition the message is displayed. Also faulty (missing) lamp can be reason of the message.

#### Lamp Error

This message appears if the lamp was switched off without command of the lamp control software.

#### Overheated

This message informs that the fixture head has been overheated and the lamp was switched off by means of the head temperature sensor (sensor Head Temperature).

#### Base Overheated

This message informs that the fixture base has been overheated and the lamp was switched off by means of the temperature sensor (sensor Ambient Temperature) in the base. Before switching the lamp on again, the fixture must be disconnected from mains and connected once again.

#### Temper.Sensor Error

The message informs you that the communication between the temperature sensor in the fixture head and its processor failed and the lamp has been switched off.

#### Internal Error 1

Communication error between PCBs (error or noise was detected on communication wires)

#### Internal Error 2

Ballast communication error (some PCB has failed or is disconnected (this PCB will show as N/A in menu --> Information --> Software versions) or error/noise was detected on communication wires)

### **Tilt Error 1 (Tilt Error 2)**

This message will appear after the reset of the fixture if the head's magnetic-indexing circuit malfunctions (sensor failed or magnet is missing) or the stepping motor is defective or its driving IC on the PCB. The head is not located in the default position after the reset.

### **Tilt Error 3**

This message signalizes error of the tilt feedback. Check connection of the tilt sensor.

### **Pan Error 1 (Pan Error 2)**

This message will appear after the reset of the fixture if the yoke's magnetic-indexing circuit malfunctions (sensor failed or magnet is missing) or the stepping motor is defective or its driving IC on the PCB. The yoke is not located in the default position after the reset of the fixture.

### **Pan Error 3**

This message signalizes error of the pan feedback. Check connection of the pan sensor.

### **Pan/Tilt EMS Call Error**

If the message appears, run Pan/Tilt EMS calibration (tab Service --> Calibration --> Calibrate Pan/Tilt EMS)

### **Colour Wheel 1 Error 1(Colour Wheel 1 Error 2)**

The messages will appear after the reset of the colour wheel if this wheel is not located in the default position.

### **Colour Wheel 2 Error 1(Colour Wheel 2 Error 2)**

The messages will appear after the reset of the colour wheel if this wheel is not located in the default position.

### **Cyan Lamella Error 1 (Cyan Error 2 )**

The messages will appear after the reset of the cyan flag if the flag is not located in the default position.

### **Magenta Lamella Error 1 (Magenta Error 2 )**

The messages will appear after the reset of the magenta flags if the flag is not located in the default position.

### **Yellow Lamella Error 1 (Yellow Error 2 )**

The messages will appear after the reset of the yellow flags if the flag is not located in the default position.

### **CTO Lamella Error 1 (CTO Lamella Error 2)**

The messages will appear after the reset of the CTO flag if the flag is not located in the default position.

### **Prism 1 Error 1 (Prism 1 Error 2 )**

The messages will appear after the reset of the 6-facet linear prism if this prism is not located in the default position.

### **Prism 1 Rot. Error 1 (Prism 1 Rot. Error 2 )**

The messages will appear after the reset of the 6-facet linear prism if the prism rotation is not in the default position.

### **Prism 2 Error 1 (Prism 2 Error 2 )**

The messages will appear after the reset of the 6-facet axial prism if this prism is not located in the default position.

### **Zoom Error 1 (Zoom Error 2 )**

The messages will appear after the reset of the zoom module if the zoom lens is not located in the default position.

### **Focus 1 Error 1 (Focus 1 Error 2 )**

The messages will appear after the reset of the focus module if the focus module 1 is not located in the default position.

### **Focus 2 Error 1 (Focus 2 Error 2 )**

The messages will appear after the reset of the focus module if the focus module 2 is not located in the default position.

### **Gobo Carousel Error 1 (Gobo Carousel Error 2 )**

The messages will appear after the reset of the gobo carousel 1 if this wheel is not located in the default position.

### **Gobo rotation Error 1 (Gobo Rotation Error 2 )**

The messages will appear after the reset of the rotating gobo wheel 1 if the rotating gobos are not located in the default positions.

**Static Gobo Error 1 (Static Gobo Error 2 )**

The messages will appear after the reset of the static gobo wheel if this wheel is not located in the default position.

**Faulty battery**

The battery on the display board is exhausted and should be replaced immediately.

**Vcc 5V failure**

The 5V supply failure has appeared.

**Vcc 48V failure**

The 48V supply failure has appeared.

**Lamp Fan 1 (2) Bad, Lamp Off**

One of the blowers (Fan 1, Fan 2) cooling the lamp malfunctioned and the lamp was switched off.

**Front Fan Bad, Lamp Off.**

One of the sucking fans (Fan 6, Fan 7) in the fixture head malfunctioned and the lamp was switched off.

**Base Fan Bad, Lamp Off**

One of the fans (Fan 9, Fan 10) in the fixture base malfunctioned and the lamp was switched off.

**CMY Fans Bad, Lamp Off**

Both fans (Fan 3, Fan 4) in the CMY module in the fixture head malfunctioned and the lamp was switched off.

**CMY Fan Bad, Lamp P. Reduced**

One of the fans (Fan 3, Fan 4) in the CMY module in the fixture head malfunctioned and the lamp power has been reduced.

**Gobo Fan Bad, Lamp P. Reduced**

The gobo blower (Fan 5) at gobo wheels in the fixture head malfunctioned and the lamp power is reduced when the gobo wheel 1 (2) or animation wheel is moving into the light beam.

**FS Fans Bad, Lamp Off**

Both blowers (Fan 11, Fan 12) of the framing shutters module in the fixture head malfunctioned and the lamp was switched off.

**FS Fan Bad, Lamp P. Red.**

One of the blowers (Fan 11, Fan 12) of the framing shutters module in the fixture head malfunctioned and the lamp power has been reduced.

**Arm Fan Bad**

The small fan (Fan 8) in the fixture arm malfunctioned.

Fans location:

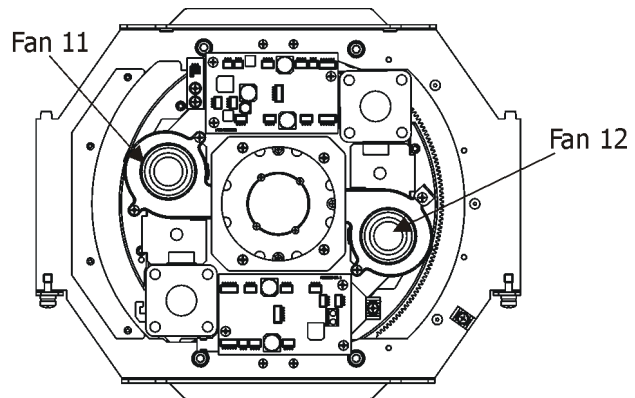
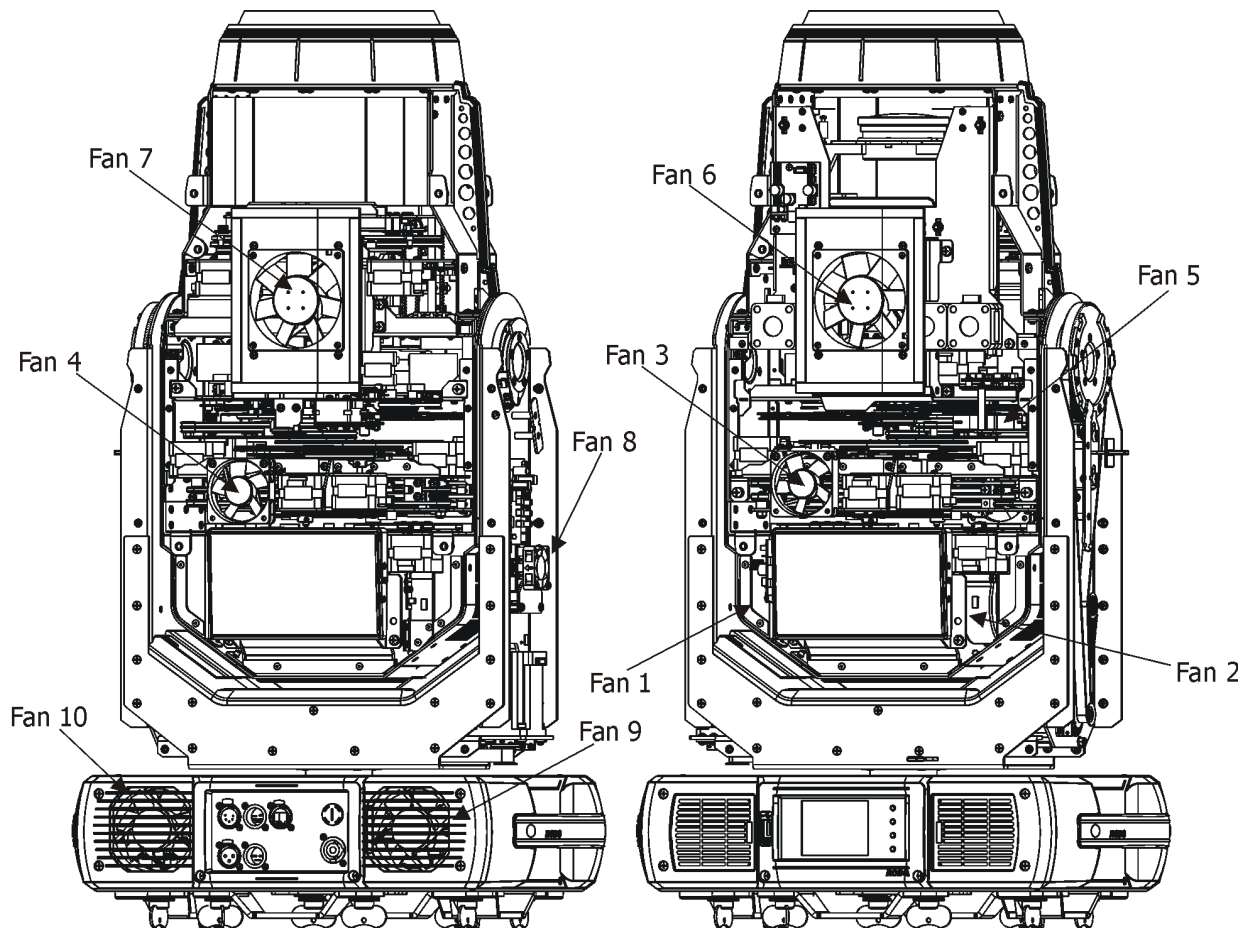

Framing shutters module

# 11. Technical Specifications

## Electrical

Power supply: electronic auto-ranging  
Input voltage range: 200-240V, 50-60Hz  
Power consumption:  
Lamp power 1700W..... 2000W (power factor=0.99, I=8.96 A@230V)  
Lamp power 1500W..... 1820W (power factor=0.99, I=8.04 A @230V)  
Fuse: T 12 A/250V

## Lamp

Osram Lok-it! HTI 1700/PS (140,000 lumens, CRI=92+, CCT=6000K,  
750 hrs. life @ 1700W/1500W/Quiet mode )  
Base: PGJ28 Lok-it!

## Ballast

Electronic

## Optical System

High luminous-efficiency glass reflector  
Zoom range: 5 °- 55° (open hole); 5° – 48° (gobo)

## Colour wheel 1

6 dichroic filters (deep red, deep blue, orange, green, magenta, congo blue) + open

## Colour wheel 2

6 replaceable 'SLOT&LOCK' dichroic filters (pink, lavender, laser green, CTB,  
minus 1/1 green, minus 1/2 green) + open

## CMY + CTO mixing module

Smooth CMY colour mixing system  
Colour temperature correction filter lowers the colour temperature to 2700 K  
98 colour macros

## Rotating gobo wheel

6 glass gobos can be indexed and rotated in both directions at different speeds  
Gobo wheel continuous rotation  
Glass gobos: outside diameter=30.8 mm, image diameter=25 mm, max. thickness=3.5 mm, high  
temperature borofloat or better glass  
"Slot&lock" system for easy replacement of gobos

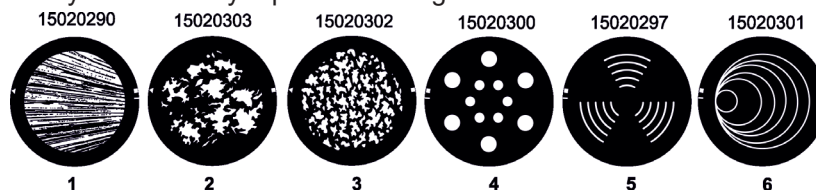

## Static gobo wheel

8 replaceable 'SLOT&LOCK' glass gobos , outside diameter= 30.8 mm,  
image diameter=25 mm, max. thickness=1.1 mm  
Gobo wheel continuous rotation

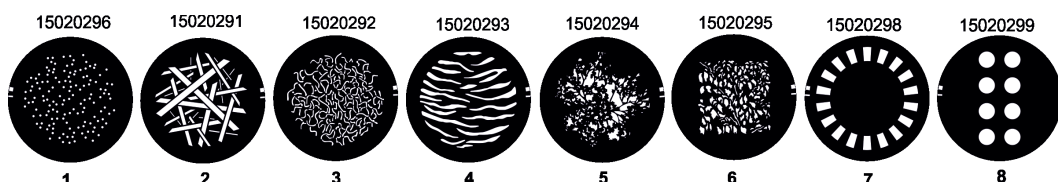

**Prism**

2 rotating prisms (6-facet linear, 6-facet axial) with continuous rotation in both directions

**Iris**

Motorized iris for different beam diameters

**Frost filters**

3 separate, variable frost filters (light, medium, heavy)  
Replaceable light filter

**Zoom**

Linear motorized zoom

**Effect wheel**

Effect wheel rotating in both directions

**Strobe**

Strobe effect with variable speed (up to 10 Hz)  
Electronic strobe

**Dimmer**

Smooth dimmer from 0 - 100 %

**Control**

Graphic touch screen for fixture setting and addressing  
Gravitation sensor for auto screen positioning  
Battery backup of the touch screen  
Readout fixture and lamp usage, receiving DMX values, temperatures, etc  
Built-in analyzer for easy fault finding, error messages  
Remotely switching on/off the lamp  
Black-out while head moving or colour changing  
Pan/Tilt electronic motion stabilizer  
Stand-alone operation  
3 user editable programs, each up to 100 steps  
Supported protocols: USITT DMX 512, RDM, ArtNet, MANet, MANet2, sACN  
Support of RDM (Remote Device Management)  
2 DMX modes (49, 42 control channels)

**Wireless DMX/RDM module (Wireless DMX version only)**

Compliance with USITT DMX-512 (1986 & 1990) and 512-A  
Full DMX fidelity and frame integrity  
Auto sensing of DMX frame rate and frame size  
<5ms DMX latency  
Operational frequency range of 2402-2480 MHz  
Producer: LumenRadio

**Framing shutters**

4 individually positionable blades  
rotation of each blade in range of 50°  
rotation of the complete framing system in range of 90°

**Pan/Tilt**

Pan movement range 540°  
Tilt movement range 270°  
16 bit movement resolution  
Automatic Pan/Tilt position correction  
Remotely controllable speed of pan/tilt movement for easy programming  
Pan/tilt-lock mechanism



## Rigging

Mounting points: 2 pairs of 1/4-turn locks  
Mounting horizontally or vertically via 2 Omega brackets

## Temperatures

Maximum ambient temperature: 45°C (for CE)  
25°C (for cETLus)  
Maximum housing temperature : 170° C (at air vents in fixture head)

## Minimum distances

Min. distance from flammable surfaces: 1 m  
Min. distance to alight object: 8 m

## Connection

DMX data in/out: Locking 3-pin and 5-pin XLR  
ArtNet: RJ 45 (Neutrik Ethercon)  
AC power IN: Chassis connector Neutrik PowerCon, A-type, NAC3MPA

## Total heat dissipation

6480 BTU/h (calculated)

## Weight (net):

37.9 kg

## Dimensions (mm)

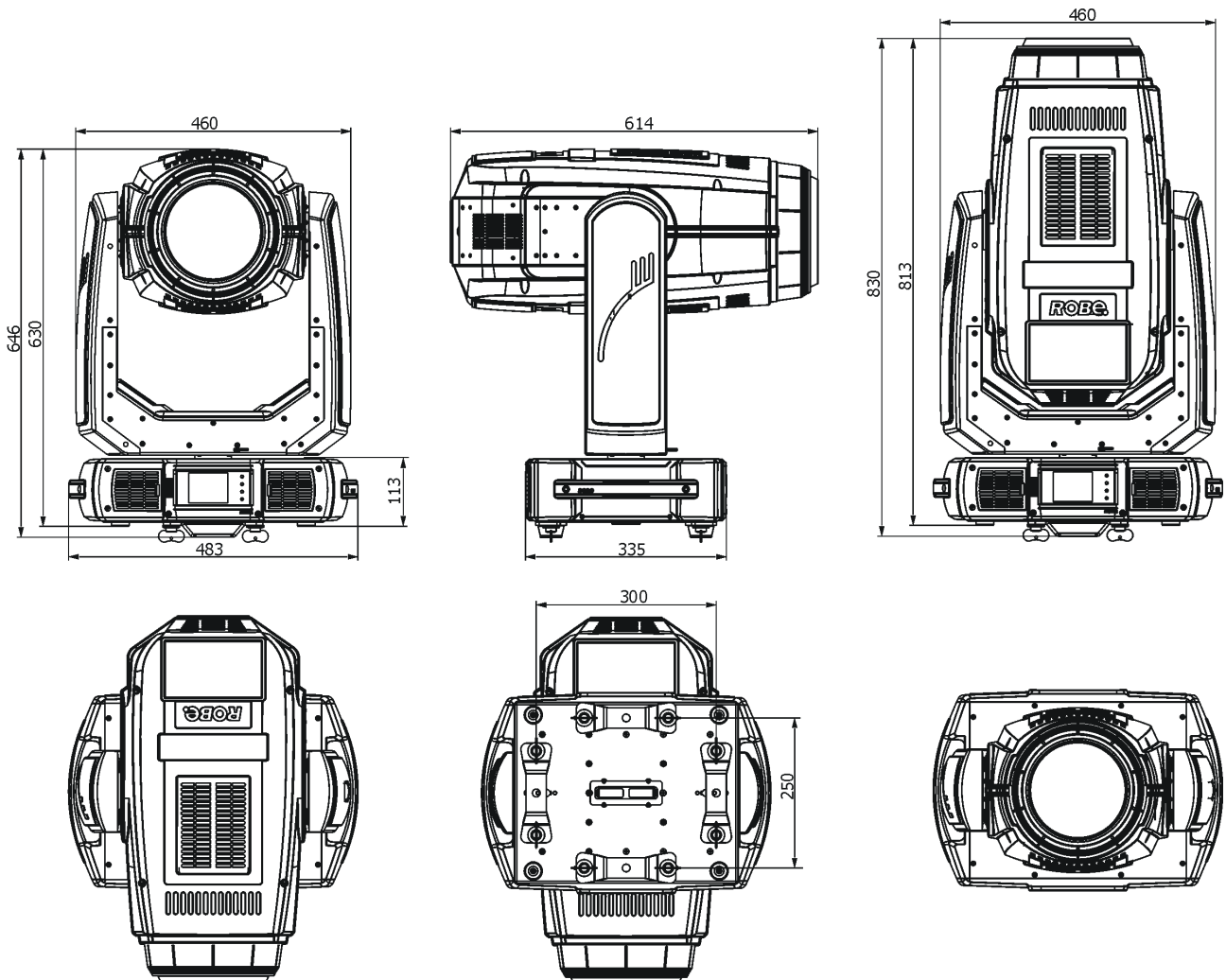

**Accessories**

- 1 x Omega adaptor CL-regular 2 pcs in box (P/N 10980033)
- 1 x Power cable

**Optional accessories**

- BMFL Handles 2 pcs (P/N 10980233)
- BMFL Side Handle (P/N 10980396)
- Upgrade kit CRMX Universal 260 (P/N 99030100)
- Doughty Trigger Clamp (P/N 17030386)
- Safety wire 50 kg (P/N 99011957)
- Lamp Osram Lok-it HTI 1700/PS (P/N 14080049)
- Robin BMFL LightMaster side kit SET(P/N 10080281) /Cardboard/
- Robin BMFL LightMaster side kit SET(P/N 10580281) /Single Top Loader Case/
- Robin BMFL LightMaster rear kit SET (P/N 10080282) /Cardboard/
- Robin BMFL LightMaster rear kit SET (P/N 10580282) /Single Top Loader Case/

**Photometric diagrams**

**Min. Zoom**

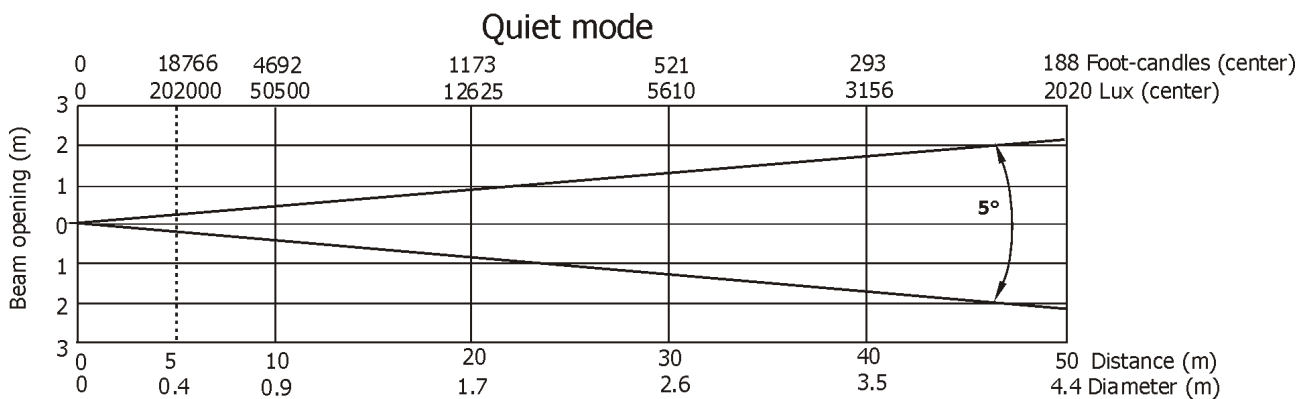
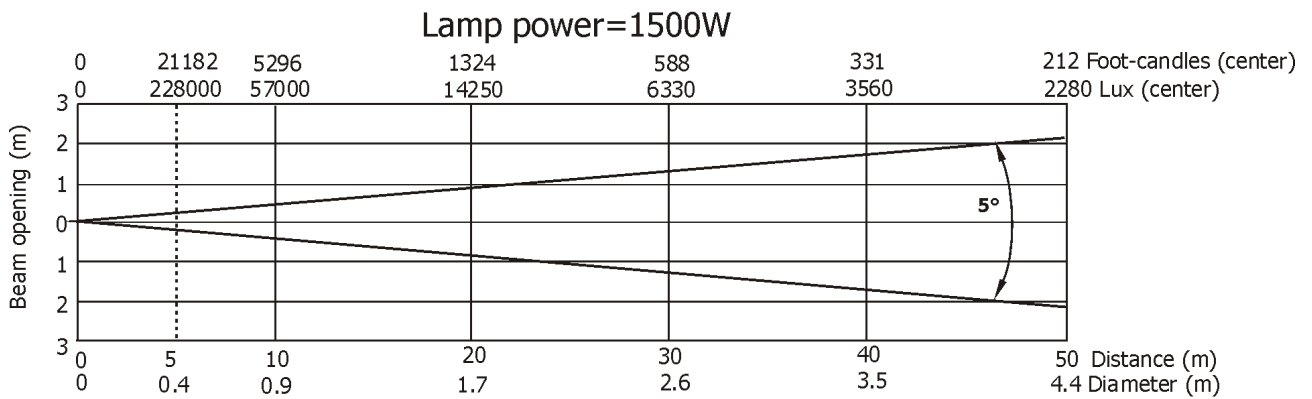
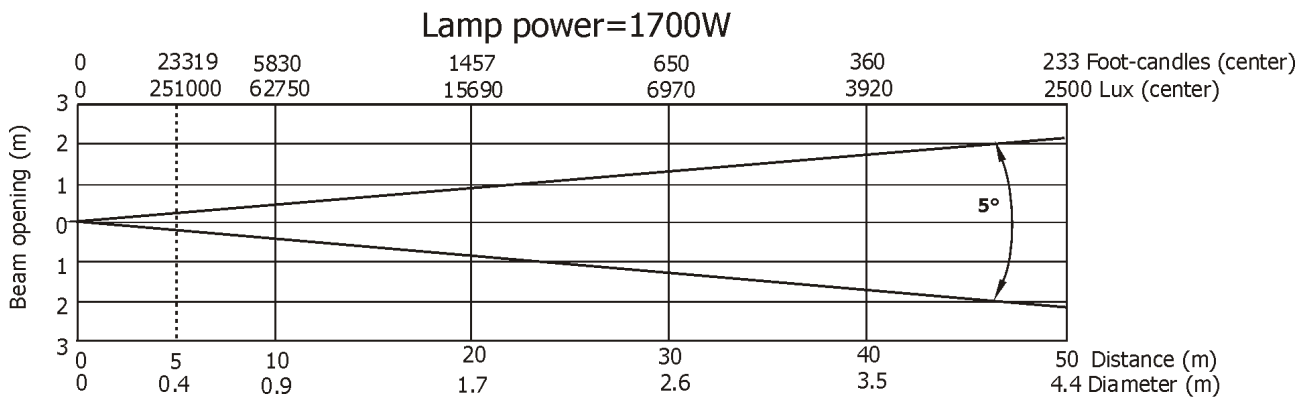

# Max. Zoom

Lamp power=1700W

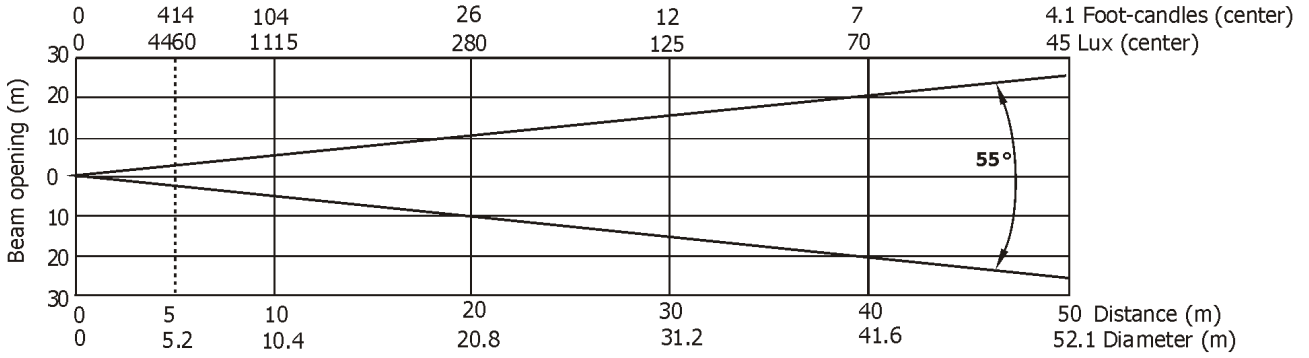

Lamp power=1500W

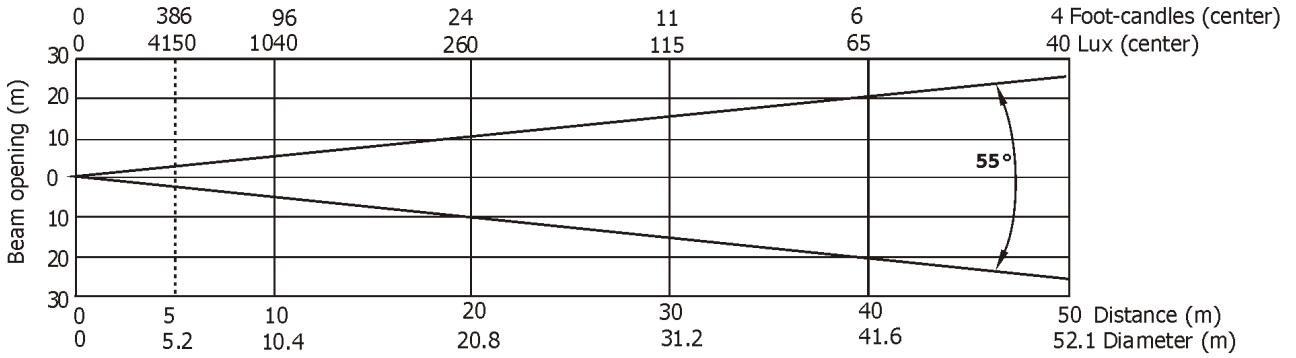

Quiet mode

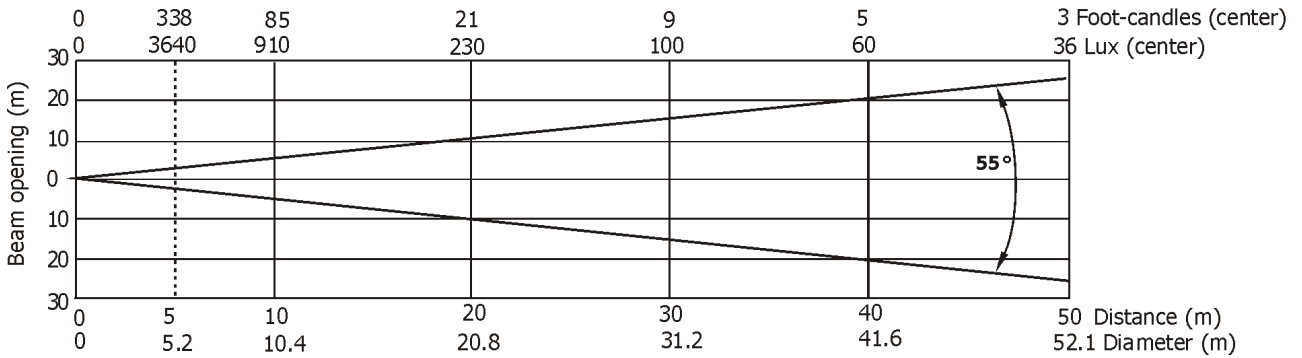

## 12. Maintenance and cleaning

It is absolutely essential that the fixture is kept clean and that dust, dirt and smoke-fluid residues must not build up on or within the fixture. Otherwise, the fixture's light-output will be significantly reduced. Regular cleaning will not only ensure the maximum light-output, but will also allow the fixture to function reliably throughout its life. A soft lint-free cloth moistened with any good glass cleaning fluid is recommended, under no circumstances should alcohol or solvents be used!

**DANGER !**  
**Disconnect from the mains before starting any  
maintenance work**

The front objective lens will require weekly cleaning as smoke-fluid tends to building up residues, reducing the light-output very quickly. The cooling-fans should be cleaned monthly.

The interior of the fixture should be cleaned at least annually using a vacuum-cleaner or an air-jet.

Dichroic colour filters, CMY lamellas, gobo and effect wheels and the internal lenses should be cleaned monthly. Remove dust and dirt from the fans and cooling vents using a soft brush and vacuum-cleaner.

**Important! Check the air filters periodically and clean before they become  
clogged!**

Clean two air filters placed in the fixture's covers and two in the fixture base. Use a vacuum cleaner, compressed air or you can wash them and put back dry.

After replacing the air filters, reset the elapsed time counter in the menu "Information" (Information--->Air Filters---> Elapsed Time).

### Replacing the fuse.

Before replacing the fuse, unplug mains lead.

- 1) Remove the fuse holder on the rear panel of the base with a fitting screwdriver from the housing (anti-clockwise).
- 2) Remove the old fuse from the fuse holder.
- 3) Install the new fuse in the fuse holder (only the same type and rating).
- 4) Replace the fuseholder in the housing and fix it.

## 13. ChangeLog

This section summarizes all types of changes in the user manual.

Version of the manual	Date of issue	Description of changes
1.1	20/05/2015	Replacement of the light frost added.
1.2	06/04/2016	DMX chart version 1.2 (Silent mode renamed to Quiet mode)
1.3	17/10/2016	DMX chart version 1.3 (Home position on Power/Special Functions added)
1.4	03/04/2017	DMX chart version 1.4 (Colour macros renamed)
1.5	16/08/2017	DMX chart version 1.5 (LightMaster and RoboSpot support added)
1.6	30/08/2017	DMX chart version 1.6 (LightMaster and RoboSpot support modified)
1.7	11/01/2018	Optional accessories changed
1.8	02/07/2018	Added notice for manipulation with powerCon..
1.9	11/07/2018	Rot. gobo replace description changed

July 2, 2018

Copyright © 2015-2018 Robe Lighting - All rights reserved

All Specifications subject to change without notice

Made in CZECH REPUBLIC by ROBE LIGHTING s.r.o. Palackeho 416/20 CZ 75701 Valasske Mezirici

Robin BMFL Blade - DMX protocol				
version 1.6		Mode 1 - Standard 16 bit, Mode 2 - Reduced 8 bit		
Mode/channel		DMX Value	Function	Type of control
1	2			
1	1		<b>Pan</b>	
		0 - 255	Pan movement by 540°	proportional
2	2		<b>Pan Fine</b>	
		0 - 255	Fine control of pan movement	proportional
3	3		<b>Tilt</b>	
		0 - 255	Tilt movement by 270°	proportional
4	4		<b>Tilt fine</b>	
		0 - 255	Fine control of tilt movement	proportional
5	5		<b>Pan/Tilt speed , Pan/Tilt time</b>	
		0	Standard mode	step
		1	Max. Speed Mode	step
			<b>Pan/Tilt speed mode</b>	
		2 - 255	Speed from max. to min.	proportional
			<b>Pan/Tilt time mode</b>	
		2 - 255	Time from 0.2 s to 25.5 sec.	proportional
6	6		<b>Power/Special functions</b>	
		0 - 9	Reserved	
			<i>To activate following functions, stop in DMX value for at least 3 s and shutter must be closed at least 3 sec. („Shutter,Strobe“ channel 47/41 must be at range: 0-31 DMX). Corresponding menu items are temporarily overridden except DMX Input.</i>	
		10-14	DMX input: Wired DMX *	step
		15-19	DMX input: Wireless DMX *	step
			* function is active only 10 seconds after switching the fixture on	
		20-24	Graphic display On	step
		25-29	Graphic display Off	step
		30-34	Reserved	
		35-39	Lamp power 1500W	step
		40-44	Lamp power 1700W	step
		45-49	Quiet mode	step
		50-54	Dimmer curve: Square law	step
		55-59	Dimmer curve: Linear	step
		60-64	Fans mode: Auto	step
		65-69	Fans mode: High	step
		70-74	Home position on	step
		75-79	Home position off	step
		80-89	Reserved	
		90 - 94	Pan/Tilt speed mode	step
		95-99	Pan/Tilt time mode	step
		100 - 104	Blackout while pan/tilt moving	step
		105 -109	Disabled blackout while pan/tilt moving	step
		110-114	Blackout while colour wheels moving	step
		115 -119	Disabled blackout while colour wheels moving	step
		120-129	Reserved	
			<i>To activate following functions, stop in DMX value for at least 3 seconds.</i>	
		130 - 139	Lamp On	step

## DMX protocol

Mode/channel		DMX Value	Function	Type of control
1	2			
		140 - 149	Pan/Tilt reset	step
		150 - 159	Colour system reset	step
		160 - 169	Gobo wheels reset	step
		170 - 179	Dimmer/Shutter reset	step
		180 - 189	Zoom/focus/frost/prism reset	step
		190 - 199	Iris/framing shutters/effect wheel reset	step
		200 - 209	Total reset	step
		210 - 229	Reserved	
		230 - 239	Lamp Off	step
			The following LightMaster /RoboSpot related commands are only applicable when LightMaster/RoboSpot are connected:	
		240 - 244	LightMaster /RoboSpot enabled	step
		245 - 249	LightMaster/RoboSpot disabled - except handle faders and pan/tilt	step
		250 - 255	LightMaster/RoboSpot fully disabled (except pan/tilt at LightMaster)	step
<b>7</b>	<b>7</b>		<b>Colour wheel 1</b>	
			<b><i>Continual positioning</i></b>	
		0	Open/white	proportional
		18	Deep red	proportional
		37	Deep blue	proportional
		55	Orange	proportional
		73	Green	proportional
		91	Magenta	proportional
		110	Congo blue (UV)	proportional
		128-129	White	step
			<b><i>Positioning</i></b>	
		130-139	Deep red	step
		140-149	Deep blue	step
		150-159	Orange	step
		160-169	Green	step
		170-179	Magenta	step
		180-189	Congo blue (UV)	step
		190 - 215	Forwards rainbow effect from fast to slow	proportional
		216 - 217	No rotation	step
		218 - 243	Backwards rainbow effect from slow to fast	proportional
		244 - 249	Random colour selection by audio control (Set microphone sensitivity in menu „Personality”)	step
		250 - 255	Auto random colour selection from fast to slow	proportional
<b>8</b>	<b>*</b>		<b>Colour wheel 1 - fine positioning</b>	
		0 - 255	Fine positioning	proportional
<b>9</b>	<b>8</b>		<b>Colour wheel 2</b>	
			<b><i>Continual positioning</i></b>	
		0	Open/white	proportional
		18	Pink	proportional
		37	Lavander	proportional
		55	Laser green	proportional
		73	CTB	proportional
		91	minus 1/1 green	proportional
		110	minus 1/2 green	proportional

DMX protocol

Mode/channel		DMX Value	Function	Type of control
1	2			
		128-129	White <b>Positioning</b>	step
		130-139	Pink	step
		140-149	Lavander	step
		150-159	Laser green	step
		160-169	CTB	step
		170-179	minus 1/1 green	step
		180-189	minus 1/2 green	step
		190 - 215	Forwards rainbow effect from fast to slow	proportional
		216 - 217	No rotation	step
		218 - 243	Backwards rainbow effect from slow to fast	proportional
		244 - 249	Random colour selection by audio control (Set microphone sensitivity in menu „Personality“)	step
		250 - 255	Auto random colour selection from fast to slow	proportional
<b>10</b>	<b>*</b>		<b>Colour wheel 2 - fine positioning</b>	
		0 - 255	Fine positioning	proportional
<b>11</b>	<b>9</b>		<b>Cyan</b>	
		0 - 255	Cyan (0-white, 255-full cyan)	proportional
<b>12</b>	<b>10</b>		<b>Magenta</b>	
		0 - 255	Magenta (0-white, 255-full magenta)	proportional
<b>13</b>	<b>11</b>		<b>Yellow</b>	
		0 - 255	Yellow (0-white, 255-full yellow)	proportional
<b>14</b>	<b>12</b>		<b>CTO filter</b>	
		0 - 255	(0-6000K, 255-2700K)	proportional
<b>15</b>	<b>13</b>		<b>CMY +CTO + CW1+CW2 macros</b>	
			See table "Colour macros" to find components of each colour The following channels are disabled: 7-14 (Mode 1),7-12 (Mode2)	
		0 - 7	No function	step
		8 - 9	Colour Macro 1	step
		10-11	Colour Macro 2	step
		12-13	Colour Macro 3	step
		14-15	Colour Macro 4	step
		16-17	Colour Macro 5	step
		18-19	Colour Macro 6	step
		20-21	Colour Macro 7	step
		22-23	Colour Macro 8	step
		24-25	Colour Macro 9	step
		26-27	Colour Macro 10	step
		28-29	Colour Macro 11	step
		30-31	Colour Macro 12	step
		32-33	Colour Macro 13	step
		34-35	Colour Macro 14	step
		36-37	Colour Macro 15	step
		38-39	Colour Macro 16	step
		40-41	Colour Macro 17	step
		42-43	Colour Macro 18	step
		44-45	Colour Macro 19	step
		46-47	Colour Macro 20	step

DMX protocol

Mode/channel		DMX Value	Function	Type of control
1	2			
		48-49	Colour Macro 21	step
		50-51	Colour Macro 22	step
		52-53	Colour Macro 23	step
		54-55	Colour Macro 24	step
		56-57	Colour Macro 25	step
		58-59	Colour Macro 26	step
		60-61	Colour Macro 27	step
		62-63	Colour Macro 28	step
		64-65	Colour Macro 29	step
		66-67	Colour Macro 30	step
		68-69	Filter 4 (Medium Bastard Amber)	step
		70-71	Filter 10 (Medium Yellow)	step
		72-73	Filter 19 (Fire)	step
		74-75	Filter 26 (Bright Red)	step
		76-77	Filter 58 (Lavender)	step
		78-79	Filter 68 (Sky Blue)	step
		80-81	Filter 71 (Tokyo Blue)	step
		82-83	Filter 79 (Just Blue)	step
		84-85	Filter 88 (Lime Green)	step
		86-87	Filter 90 (Dark Yellow Green)	step
		88-89	Filter 100 (Spring Yellow)	step
		90-91	Filter 101 (Yellow)	step
		92-93	Filter 102 (Light Amber)	step
		94-95	Filter 103 (Straw)	step
		96-97	Filter 104 (Deep Amber)	step
		98-99	Filter 105 (Orange)	step
		100-101	Filter 106 (Primary Red)	step
		102-103	Filter 111 (Dark Pink)	step
		104-105	Filter 115 (Peacock Blue)	step
		106-107	Filter 116 (Medium Blue-Green)	step
		108-109	Filter 117 (Steel Blue)	step
		110-111	Filter 118 (Light Blue)	step
		112-113	Filter 119 (Dark Blue)	step
		114-115	Filter 120 (Deep Blue)	step
		116-117	Filter 121 (Filter Green)	step
		118-119	Filter 128 (Bright Pink)	step
		120-121	Filter 131 (Marine Blue)	step
		122-123	Filter 132 (Medium Blue)	step
		124-125	Filter 134 (Golden Amber)	step
		126-127	Filter 135 (Deep Golden Amber)	step
		128-129	Filter 136 (Pale Lavender)	step
		130-131	Filter 137 (Special Lavender)	step
		132-133	Filter 138 (Pale Green)	step
		134-135	Filter 139 (Primary Green)	step
		136-137	Filter 141 (Bright Blue)	step
		138-139	Filter 147 (Apricot)	step
		140-141	Filter 148 (Bright Rose)	step
		142-143	Filter 152 (Pale Gold)	step



DMX protocol

Mode/channel		DMX Value	Function	Type of control
1	2			
		144-145	Filter 154 (Pale Rose)	step
		146-147	Filter 157 (Pink)	step
		148-149	Filter 158 (Deep Orange)	step
		150-151	Filter 162 (Bastard Amber)	step
		152-153	Filter 164 (Flame Red)	step
		154-155	Filter 165 (Daylight Blue)	step
		156-157	Filter 169 (Lilac Tint)	step
		158-159	Filter 170 (Deep Lavender)	step
		160-161	Filter 172 (Lagoon Blue)	step
		162-163	Filter 179 (Chrome Orange)	step
		164-165	Filter 180 (Dark Lavender)	step
		166-167	Filter 181 (Congo Blue)	step
		168-169	Filter 197 (Alice Blue)	step
		170-171	Filter 201 (Full C.T. Blue)	step
		172-173	Filter 202 (Half C.T. Blue)	step
		174-175	Filter 203 (Quarter C.T. Blue)	step
		176-177	Filter 204 (Full C.T. Orange)	step
		178-179	Filter 205 (Half C.T. Orange)	step
		180-181	Filter 206 (Quarter C.T. Orange)	step
		182-183	Filter 247 (Filter Minus Green)	step
		184-185	Filter 248 (Half Minus Green)	step
		186-187	Filter 281 (Three Quarter C.T. Blue)	step
		188-189	Filter 285 (Three Quarter C.T. Orange)	step
		190-191	Filter 352 (Glacier Blue)	step
		192-193	Filter 353 (Lighter Blue)	step
		194-195	Filter 715 (Cabana Blue)	step
		196-197	Filter 778 (Millennium Gold)	step
		198-199	Filter 793 (Vanity Fair)	step
		200-243	Reserved	
		244 - 249	Random macro selection by audio control (Set microphone sensitivity in menu "PErsonality")	step
		250 - 255	Auto random macro selection from fast to slow	proportional
<b>16</b>	<b>14</b>		<b>Effect Speed</b>	
			<i>Speed of CMY&amp;CTO movement and Rot./Static Gobo selection</i>	
		0-255	Speed of CMY+CTO movement from max. to min.	proportional
		0-255	Speed of Rot. gobo & Static gobo selection from max. to min.	proportional
<b>17</b>	<b>15</b>		<b>CMY+CTO+Colour wheel time</b>	
		0	Function is off	step
		1 - 255	Time of CMY, CTO and Colour wheel movement (0.1sec-->25.5sec.)	proportional
<b>18</b>	<b>16</b>		<b>Framing shutters+Zoom+Focus+Frost+Iris+Prism time</b>	
		0	Function is off	step
		1 - 255	Time of framing shutters, zoom, focus, iris and frost movement (0.1 sec-->25.5 sec.)	proportional
		1-50	Time of prism movement (0.1 sec-->5 sec.)	proportional
<b>19</b>	<b>17</b>		<b>Effect wheel positioning</b>	
		0-19	No function	step
		20-127	Proportional indexing (73-center)	proportional
		128-170	Ramping from open to full position ( max-->min. speed)	proportional

DMX protocol

Mode/channel		DMX Value	Function	Type of control
1	2			
		171-213	Ramping from open to half position ( max. --->min. speed)	proportional
		214-255	Ramp. from half position to full position ( max. --->min. speed)	proportional
<b>20</b>	<b>18</b>		<b>Effect wheel rotation</b>	
		0	No rotation	step
		1 - 127	Forwards rotation from fast to slow	proportional
		128	No rotation - <u>default</u>	step
		129 -255	Backwards rotation from slow to fast	proportional
<b>21</b>	<b>19</b>		<b>Effect wheel animations</b>	
		0-7	No animation	
			<b>Note</b> : Set suitable DMX value at <b>Focus</b> channel to get desired animation. All animations were created at distance 5 m from screen with zoom=128DMX, Focus=200DMX	
			<b>Coloured animations.</b> <i>The channels are blocked: Colour wheel 1 and 2, CMY+CMY macros, Effect wheel positioning, Effect wheel rotation, stat. Gobo, Rotat. gobo, gobo rotation, Prism, Prism rotation</i>	
		8-9	Animation Macro 1	step
		10-11	Animation Macro 2	step
		12-13	Animation Macro 3	step
		14-15	Animation Macro 4	step
		16-17	Animation Macro 5	step
		18-19	Animation Macro 6	step
		20-21	Animation Macro 7	step
		22-23	Animation Macro 8	step
		24-25	Animation Macro 9	step
		26-27	Animation Macro 10	step
			<b>Black and white animations.</b> <i>The channels are blocked: Effect wheel positioning, Effect wheel rotation, stat. Gobo, Rotat. gobo, gobo rotation, Prism, Prism rotation</i>	
		28-29	Animation Macro 1	step
		30-31	Animation Macro 2	step
		32-33	Animation Macro 3	step
		34-35	Animation Macro 4	step
		36-37	Animation Macro 5	step
		38-39	Animation Macro 6	step
		40-41	Animation Macro 7	step
		42-43	Animation Macro 8	step
		44-45	Animation Macro 9	step
		46-47	Animation Macro 10	step
		48-255	Reserved	
<b>22</b>	<b>20</b>		<b>Static gobo wheel</b>	
		0-7	Open/hole	step
			<b>Positioning</b>	
		8-19	Gobo 1	step
		20-31	Gobo 2	step
		32-43	Gobo 3	step
		44-55	Gobo 4	step
		56-67	Gobo 5	step
		68-79	Gobo 6	step

DMX protocol

Mode/channel		DMX Value	Function	Type of control
1	2			
		80-91	Gobo 7	step
		92-103	Gobo 8	step
			<b><i>Shaking gobos from slow to fast</i></b>	
		104-115	Gobo 1	proportional
		116-127	Gobo 2	proportional
		128-139	Gobo 3	proportional
		140-151	Gobo 4	proportional
		152-163	Gobo 5	proportional
		164-175	Gobo 6	proportional
		176-187	Gobo 7	proportional
		188-199	Gobo 8	proportional
		200 - 201	Open/hole	step
		202 - 222	Forwards gobo wheel rotation from fast to slow	proportional
		223 - 243	Backwards gobo wheel rotation from slow to fast	proportional
		244 - 249	Random gobo selection by audio control	step
			<i>(Set microphone sensitivity in menu „Personality“)</i>	
		250 - 255	Auto random gobo selection from fast to slow	proportional
<b>23</b>	<b>21</b>		<b>Rotating gobo wheel</b>	
			<i>In the range of 0-59 DMX the gobo selection speed is controlled by the Effect Speed channel.</i>	
			<b><i>Index - set indexing on channel 24/22</i></b>	
		0-4	Open/hole	step
		5-8	Gobo 1	step
		9-13	Gobo 2	step
		14-17	Gobo 3	step
		18-22	Gobo 4	step
		23-26	Gobo 5	step
		27-31	Gobo 6	step
			<b><i>Rotation - set rotation on channel 27/24</i></b>	
		32-35	Gobo 1	step
		36-40	Gobo 2	step
		41-44	Gobo 3	step
		45-49	Gobo 4	step
		50-54	Gobo 5	step
		55-59	Gobo 6	step
			<b><i>Shaking gobos from slow to fast</i></b>	
			<b><i>Index - set indexing on channel 24/22</i></b>	
		60-71	Gobo 1	proportional
		72-83	Gobo 2	proportional
		84-95	Gobo 3	proportional
		96-106	Gobo 4	proportional
		107-118	Gobo 5	proportional
		119-129	Gobo 6	proportional
			<b><i>Shaking gobos from slow to fast</i></b>	
			<b><i>Rotation - set rotation on channel 24/22</i></b>	
		130-141	Gobo 1	proportional
		142-153	Gobo 2	proportional
		154-165	Gobo 3	proportional

## DMX protocol

Mode/channel		DMX Value	Function	Type of control
1	2			
		166-176	Gobo 4	proportional
		177-188	Gobo 5	proportional
		189-199	Gobo 6	proportional
		200 - 201	Open/hole	step
		202 - 221	Forwards gobo wheel rotation from fast to slow	proportional
		222-223	No rotation	
		224 - 243	Backwards gobo wheel rotation from slow to fast	proportional
		244 - 249	Random gobo selection by audio control	step
			(Set microphone sensitivity in menu „Personality“)	
		250 - 255	Auto random gobo selection from fast to slow	proportional
<b>24</b>	<b>22</b>		<b>Rot. Gobo indexing/rotation</b>	
			<b><i>Gobo indexing - set position on channel 23/21</i></b>	
		0 - 255	Gobo indexing	proportional
			<b><i>Gobo rotation - set position on channel 23/21</i></b>	
		0	No rotation	step
		1 - 127	Forwards gobo rotation from fast to slow	proportional
		128	No rotation - <u>default</u>	step
		129 - 255	Backwards gobo rotation from slow to fast	proportional
<b>25</b>	<b>*</b>		<b>Rot. Gobo indexing/rotation - fine</b>	
		0-255	Fine indexing (rotation)	proportional
<b>26</b>	<b>23</b>		<b>Prism</b>	
		0 - 19	Open position (hole)	step
		20 -49	6-facet linear prism -indexing	step
		50 - 75	6-facet linear prism - rotation	step
		76 - 105	6-facet circular prism- Indexing	step
		106-127	6-facet circular prism-rotation	step
			<b><i>Prism/gobo macros</i></b>	
			The channels are blocked: Prism, prism rot., rot. gobo, gobo rot.	
		128 - 135	Macro 1	step
		136 - 143	Macro 2	step
		144 - 151	Macro 3	step
		152 - 159	Macro 4	step
		160 - 167	Macro 5	step
		168 - 175	Macro 6	step
		176 - 183	Macro 7	step
		184 - 191	Macro 8	step
		192 - 199	Macro 9	step
		200 - 207	Macro 10	step
		208 - 215	Macro 11	step
		216 - 223	Macro 12	step
		224 - 231	Macro 13	step
		232 - 239	Macro 14	step
		240 - 247	Macro 15	step
		248 - 255	Macro 16	step
<b>27</b>	<b>24</b>		<b>Prism rotation</b>	
		0	No rotation	step
		1 - 127	Forwards rotation from fast to slow	proportional

DMX protocol

Mode/channel		DMX Value	Function	Type of control
1	2			
		128	No rotation - <u>default</u>	step
		129-255	Backwards rotation from slow to fast	proportional
<b>28</b>	<b>25</b>		<b>Frost</b>	
		0	Open- <u>default</u>	step
			<b>Light</b>	
		1-50	Frost from 0% to 100%	proportional
		51-53	100% frost	step
		54-63	Pulse closing from slow to fast	proportional
		64-73	Pulse opening from fast to slow	proportional
		74-83	Ramping from fast to slow	proportional
		84-86	Open	step
			<b>Medium</b>	
		87-136	Frost from 0% to 100%	proportional
		137-139	100% frost	step
		140-149	Pulse closing from slow to fast	proportional
		150-159	Pulse opening from fast to slow	proportional
		160-169	Ramping from fast to slow	proportional
		170-172	Open	step
			<b>Heavy</b>	
		173-222	Frost from 0% to 100%	proportional
		223-225	100% frost	step
		226-235	Pulse closing from slow to fast	proportional
		236-245	Pulse opening from fast to slow	proportional
		246-255	Ramping from fast to slow	proportional
<b>29</b>	<b>26</b>		<b>Iris</b>	
		0	Open	step
		1 - 179	From max.diameter to min.diameter	proportional
		180 - 191	Closed	step
			<b>Pulse effects with Iris blackout:</b>	
		192 -219	Pulse opening from slow to fast	proportional
		220 - 247	Pulse closing from fast to slow	proportional
		248 - 249	Random pulse opening (fast)	step
		250 - 251	Random pulse opening (slow)	step
		252 - 253	Random pulse closing (fast)	step
		254 - 255	Random pulse closing (slow)	step
<b>30</b>	<b>*</b>		<b>Iris - fine</b>	
		0 - 255	Fine iris movement	proportional
<b>31</b>	<b>27</b>		<b>Zoom</b>	
		0 - 255	Zoom from max. to min.beam angle	proportional
<b>32</b>	<b>*</b>		<b>Zoom - fine</b>	
		0-255	Fine zooming	proportional
<b>33</b>	<b>28</b>		<b>Focus</b>	
		0 - 255	Continuous adjustment from far to near	proportional
<b>34</b>	<b>*</b>		<b>Focus - fine</b>	
		0- 255	Fine focusing	proportional
<b>35</b>	<b>29</b>		<b>Reserved</b>	
			Reserved for autofocus	
<b>36</b>	<b>30</b>		<b>Framing shutters module rotation</b>	

## DMX protocol

Mode/channel		DMX Value	Function	Type of control
1	2			
		0-127	Rotation from left (0°) to 45°	proportional
		128	45°	step
		129-255	Rotation from 45° to right (90°)	proportional
<b>37</b>	<b>31</b>		<b>Framing shutter 1- movement</b>	
		0-255	Movement from Outward to Inward	proportional
<b>38</b>	<b>32</b>		<b>Framing shutter 1- swivelling</b>	
		0-127	Swivelling from -25 degrees towards 0 degrees	proportional
		128	0 degrees (default)	step
		129-255	Swivelling from 0 degrees to +25 degrees	proportional
<b>39</b>	<b>33</b>		<b>Framing shutter 2- movement</b>	
		0-255	Movement from Outward to Inward	proportional
<b>40</b>	<b>34</b>		<b>Framing shutter 2- swivelling</b>	
		0-127	Swivelling from -25 degrees towards 0 degrees	proportional
		128	0 degrees (default)	step
		129-255	Swivelling from 0 degrees to +25 degrees	proportional
<b>41</b>	<b>35</b>		<b>Framing shutter 3 movement</b>	
		0-255	Movement from Outward to Inward	proportional
<b>42</b>	<b>36</b>		<b>Framing shutter 3- swivelling</b>	
		0-127	Swivelling from -25 degrees towards 0 degrees	proportional
		128	0 degrees (default)	step
		129-255	Swivelling from 0 degrees to +25 degrees	proportional
<b>43</b>	<b>37</b>		<b>Framing shutter 4 movement</b>	
		0-255	Movement from Outward to Inward	proportional
<b>44</b>	<b>38</b>		<b>Framing shutter 4- swivelling</b>	
		0-127	Swivelling from -25 degrees towards 0 degrees	proportional
		128	0 degrees (default)	step
		129-255	Swivelling from 0 degrees to +25 degrees	proportional
<b>45</b>	<b>39</b>		<b>Framing shutters macros</b>	
		0-3	No function	
		4-7	Macro 1	step
		8-11	Macro 2	step
		12-15	Macro 3	step
		16-19	Macro 4	step
		20-23	Macro 5	step
		24-27	Macro 6	step
		28-31	Macro 7	step
		32-35	Macro 8	step
		36-39	Macro 9	step
		40-43	Macro 10	step
		44-47	Macro 11	step
		48-51	Macro 12	step
		52-55	Macro 13	step
		56-59	Macro 14	step
		60-63	Macro 15	step
		64-67	Macro 16	step
		68-71	Macro 17	step
		72-75	Macro 18	step
		76-79	Macro 19	step

DMX protocol

Mode/channel		DMX Value	Function	Type of control
1	2			
		80-83	Macro 20	step
		84-87	Macro 21	step
		88-91	Macro 22	step
		92-95	Macro 23	step
		96-99	Macro 24	step
		100-103	Macro 25	step
		104-107	Macro 26	step
		108-111	Macro 27	step
		112-115	Macro 28	step
		116-119	Macro 29	step
		120-123	Macro 30	step
		124-127	Macro 31	step
		128-131	Macro 32	step
		132-135	Macro 33	step
		136-139	Macro 34	step
		140-143	Macro 35	step
		144-147	Macro 36	step
		148-151	Macro 37	step
		152-155	Macro 38	step
		156-159	Macro 39	step
		160-163	Macro 40	step
		164-167	Macro 41	step
		168-171	Macro 42	step
		172-175	Macro 43	step
		176-179	Macro 44	step
		180-183	Macro 45	step
		184-187	Macro 46	step
		188-191	Macro 47	step
		192-195	Macro 48	step
		196-199	Macro 49	step
		200-203	Macro 50	step
		204-207	Macro 51	step
		208-211	Macro 52	step
		212-255	Reserved	
<b>46</b>	<b>40</b>		<b>Framing shutters macro speed</b>	
		0- 255	Speed from slow to fast.	proportional
<b>47</b>	<b>41</b>		<b>Shutter/ strobe</b>	
		0 - 31	Shutter closed	step
		32 - 63	Shutter open	step
		64 - 95	Strobe-effect from slow to fast	proportional
		96 - 127	Shutter open	step
		128 - 143	Opening pulse in sequences from slow to fast	proportional
		144 - 159	Closing pulse in sequences from fast to slow	proportional
		160 - 191	Shutter open, Electronic strobing „ZAP“ from slow to fast	proportional
		192 - 223	Random strobe-effect from slow to fast	proportional
		224 - 255	Shutter open	step
<b>48</b>	<b>42</b>		<b>Dimmer intensity</b>	
		0 - 255	Dimmer intensity from 0% to 100%	proportional

DMX protocol

Mode/channel		DMX Value	Function	Type of control
1	2			
49	*		<b>Dimmer intensity - fine</b>	
		0 - 255	Fine dimming	proportional
Copyright © 2015-2017 Robe Lighting s.r.o. - All rights reserved				
All Specifications subject to change without notice				



Colour macros								
Color name	CW1 DMX	CW1 fine DMX	CW2 DMX	CW2 fine DMX	Cyan DMX	Magenta DMX	Yellow DMX	CTO DMX
Colour Macro 1	0	0	0	0	0	116	0	95
Colour Macro 2	0	0	0	0	0	148	0	108
Colour Macro 3	0	0	0	0	0	196	0	108
Colour Macro 4	0	0	0	0	0	255	0	98
Colour Macro 5	0	0	0	0	0	255	0	215
Colour Macro 6	0	0	0	0	0	255	161	0
Colour Macro 7	0	0	0	0	0	255	210	0
Colour Macro 8	0	0	0	0	0	255	255	0
Colour Macro 9	0	0	0	0	0	220	255	0
Colour Macro 10	0	0	0	0	0	192	255	0
Colour Macro 11	0	0	0	0	0	144	255	0
Colour Macro 12	0	0	0	0	0	97	255	0
Colour Macro 13	0	0	0	0	0	0	255	95
Colour Macro 14	0	0	0	0	0	0	255	65
Colour Macro 15	0	0	0	0	0	0	255	0
Colour Macro 16	0	0	0	0	91	0	255	0
Colour Macro 17	0	0	0	0	152	0	255	0
Colour Macro 18	0	0	0	0	213	0	255	0
Colour Macro 19	0	0	0	0	255	0	231	0
Colour Macro 20	0	0	0	0	255	0	188	0
Colour Macro 21	0	0	0	0	255	0	90	0
Colour Macro 22	0	0	0	0	255	0	70	0
Colour Macro 23	0	0	0	0	255	0	0	0
Colour Macro 24	0	0	0	0	255	57	0	0
Colour Macro 25	0	0	0	0	255	83	0	0
Colour Macro 26	0	0	0	0	255	127	0	0
Colour Macro 27	0	0	0	0	255	166	0	0
Colour Macro 28	0	0	0	0	255	226	0	0
Colour Macro 29	0	0	0	0	255	255	0	0
Colour Macro 30	0	0	0	0	255	255	95	0
Filter 4 (Medium Bastard Amber)	0	0	0	0	0	94	107	0
Filter 10 (Medium Yellow)	0	0	0	0	110	0	255	0
Filter 19 (Fire)	0	0	0	0	0	222	236	0
Filter 26 (Bright Red)	175	0	0	0	0	255	221	255
Filter 58 (Lavender)	0	0	0	0	200	166	0	0
Filter 68 (Sky Blue)	0	0	0	0	226	125	0	0
Filter 71 (Tokyo Blue)	145	0	0	0	241	116	0	0
Filter 79 (Just Blue)	0	0	0	0	254	149	0	0
Filter 88 (Lime Green)	0	0	155	0	89	0	134	0
Filter 90 (Dark Yellow Green)	0	0	0	0	228	0	236	0
Filter 100 (Spring Yellow)	0	0	0	0	128	0	231	0
Filter 101 (Yellow)	0	0	0	0	97	0	245	0
Filter 102 (Light Amber)	0	0	0	0	84	0	190	0
Filter 103 (Straw)	0	0	0	0	0	52	106	0
Filter 104 (Deep Amber)	0	0	0	0	0	9	218	0
Filter 105 (Orange)	0	0	0	0	0	132	242	0

Filter 106 (Primary Red)	155	0	135	0	91	255	0	255
Filter 111 (Dark Pink)	0	0	0	0	0	152	80	0
Filter 115 (Peacock Blue)	0	0	0	0	200	0	124	0
Filter 116 (Medium Blue-Green)	0	0	0	0	236	0	145	0
Filter 117 (Steel Blue)	0	0	0	0	106	7	0	0
Filter 118 (Light Blue)	0	0	0	0	196	76	0	0
Filter 119 (Dark Blue)	0	0	145	0	238	47	0	0
Filter 120 (Deep Blue)	145	0	0	0	79	1	0	0
Filter 121 (Filter Green)	0	0	0	0	182	0	225	70
Filter 128 (Bright Pink)	0	0	0	0	89	216	0	0
Filter 131 (Marine Blue)	0	0	0	0	173	0	125	0
Filter 132 (Medium Blue)	0	0	0	0	255	136	0	0
Filter 134 (Golden Amber)	0	0	0	0	0	108	176	0
Filter 135 (Deep Golden Amber)	0	0	0	0	0	193	246	0
Filter 136 (Pale Lavender)	0	0	0	0	104	105	0	0
Filter 137 (Special Lavender)	0	0	0	0	155	117	0	0
Filter 138 (Pale Green)	0	0	0	0	143	0	179	0
Filter 139 (Primary Green)	0	0	0	0	216	0	236	0
Filter 141 (Bright Blue)	0	0	0	0	217	74	0	0
Filter 147 (Apricot)	0	0	0	0	0	99	143	0
Filter 148 (Bright Rose)	0	0	0	0	0	210	110	0
Filter 152 (Pale Gold)	0	0	0	0	0	86	103	0
Filter 154 (Pale Rose)	0	0	0	0	0	93	101	0
Filter 157 (Pink)	0	0	0	0	0	159	117	0
Filter 158 (Deep Orange)	0	0	0	0	0	156	231	0
Filter 162 (Bastard Amber)	0	0	0	0	0	83	100	0
Filter 164 (Flame Red)	0	0	0	0	0	217	210	0
Filter 165 (Daylight Blue)	0	0	0	0	191	94	0	0
Filter 169 (Lilac Tint)	0	0	0	0	76	85	0	0
Filter 170 (Deep Lavender)	0	0	0	0	118	123	0	0
Filter 172 (Lagoon Blue)	0	0	0	0	191	0	80	0
Filter 179 (Chrome Orange)	0	0	0	0	0	90	251	0
Filter 180 (Dark Lavender)	0	0	0	0	206	166	0	0
Filter 181 (Congo Blue)	145	0	145	0	131	0	103	0
Filter 197 (Alice Blue)	0	0	0	0	203	137	0	0
Filter 201 (Full C.T. Blue)	0	0	0	0	123	95	0	0
Filter 202 (Half C.T. Blue)	0	0	0	0	96	75	0	0
Filter 203 (Quarter C.T. Blue)	0	0	0	0	73	59	0	0
Filter 204 (Full C.T. Orange)	0	0	0	0	0	71	142	0
Filter 205 (Half C.T. Orange)	0	0	0	0	0	49	106	0
Filter 206 (Quarter C.T. Orange)	0	0	0	0	0	12	93	0
Filter 247 (Filter Minus Green)	0	0	0	0	0	99	72	0
Filter 248 (Half Minus Green)	0	0	0	0	0	83	71	0
Filter 281 (Three Quarter C.T. Blue)	0	0	0	0	111	81	0	0
Filter 285 (Three Quarter C.T. Orange)	0	0	0	0	0	49	124	0
Filter 352 (Glacier Blue)	0	0	0	0	171	83	0	0
Filter 353 (Lighter Blue)	0	0	0	0	153	0	77	0
Filter 715 (Cabana Blue)	0	0	0	0	248	155	0	0
Filter 778 (Millennium Gold)	0	0	0	0	0	171	240	0
Filter 793 (Vanity Fair)	0	0	0	0	72	222	18	0

