



S-500 Snow Machine

User Manual



CONFORMS TO
ANSI/UL STD.998
CERTIFIED TO
CAN/CSA STD.
C22.2 No.104



RoHS



English

SILENT SNOW MACHINE **S-500**

User Manual

Safety Information



Please read the following safety information carefully before operating the machine. Information includes important safety information about installation, usage, and maintenance. Pay attention to all warning labels and instructions in this manual and printed on the machine.

If you have questions about how to operate the machine safely, please contact your local Antari dealer for help.

- Keep this device dry.
- Always connect to a grounded circuit to avoid risk of electrocution.
- Before connecting machine to power, always check voltage indicate on machine match to your local AC voltage. Do not use the machine if AC power voltage does not match.
- Disconnect the machine from AC power before servicing and when not in use.
- This product is for indoor use only! Do not expose to rain or moisture. If fluid is spilled, disconnect AC power and clean with a damp cloth. If fluid is spilled onto electronic parts, immediately unplug the machine and contact your local Antari dealer for advice.
- No user serviceable and modifiable parts inside. Never try to repair this product, unauthorized technician may lead machine to damage or malfunction.
- For adult use only. Never leave the machine running unattended.
- Installed in well ventilated area. Provide at least 50 cm space around the machine.
- Never add flammable liquid of any kind to the machine.
- Make sure there are no flammable materials close to the machine while operating.
- Only use Antari fluid. Other fluid may lead to heater clog and malfunction.
- If the machine fails to work, unplug the machine and stop operation immediately. Contact your local Antari dealer for advise.
- Before transporting the machine, make sure the fluid tank is completely drained.

- Smoke fluid may present health risks if swallowed. Do not drink smoke fluid. Store it securely. In case of eye contact or if fluid is swallowed immediately look for medical advice.

Unpacking and Inspection

Immediately upon receiving the machine, carefully unpack the carton, check all content to ensure that all parts are present and have been received in good condition. If any parts appear damaged or mishandled from shipping, notify the shipper immediately and retrain the packing material for inspection.

What is included:	1 x S-500 Snow Machine
	1 x Power Cord
	1 x User Manual
	1 x Fluid Tank Feed Tube
	1 x 20 Liter Fluid Tank
	1 x 10 Meter (32 ft) Hose
	1 x Nozzle

Product Dimension



Product Overview



S-500 Control Panel

- Breaker
- Main Power Switch
- Wireless Remote Antenna (Optional)
- Control Panel



Tank Capacity : 20 liters (5.2 gallon)

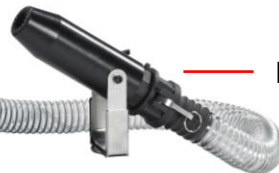

Nozzle



- XLR 3-Pin DMX Connector
- XLR 5-Pin DMX Connector
- Neutrik PowerCon
- SC-3 Wireless Remote (Optional)



SKU# PM-1 Pan Motor (Optional)

Setting Up

Step 1: Place the machine on a flat surface and in a suitable large area with at least 50 cm open space around the machine.

Step 2: Fill the fluid tank with ANTARI SL-5A Premium Water Based Snow Fluid

Step 3: Connect the machine to suitable rated power supply. To determine the power requirement for the machine refer to the label on the back of the machine.



Always connect the machine to a protected circuit and ensure it is properly grounded to avoid risk of electrocution.

Step 4: Turn on the machine, press the [VOLUME]/[DOWN] button on the control panel to start making snow.

Step 5: To turn off the machine, press the [STOP] button and put the power switch to the **OFF** position.

Operation

Control Panel Operation

The machine can be operated with onboard digital control interface

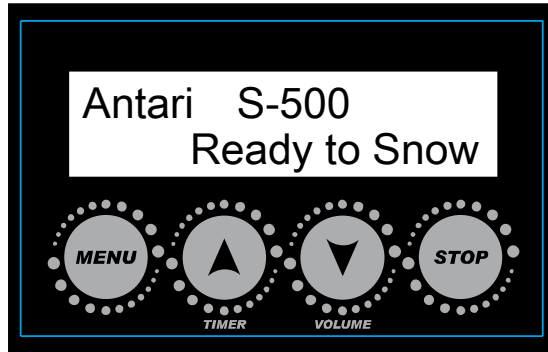

Button	Function
[MENU]	Scroll through setting menu
[UP]/[TIMER]	Up/Activate Timer function
[DOWN]/[VOLUME]	Down/Activate Volume function
[STOP]	Deactivate Timer/Volume function, Escape from menu

Control Menu

Timer Interval XXX Sec	Set interval time at timer mode from 15 to 360 sec
Timer Duration XXX Sec	Set duration time at timer mode from 5 to 120 sec
Timer Output XXX %	Set output volume at timer mode from 1 to 100%
Volume Output XXX %	Set output volume at volume mode from 1 to 100%
Fan Speed XXX %	Set fan speed from 20 to 100%
DMX-512 Address: XXX	Set DMX/W-DMX address from 1 to 511

W-DMX Power
XX

Turn On/Off W-DMX function

W-DMX Reset
XX

Unlink from W-DMX transmitter

Wireless
XX

Turn On/Off wireless remote

Wireless Register
Up:Pair Down:Del

Pair/Unpair with wireless remote.

*This menu will not be shown when Wireless is turn Off.

Run Last Setting
XX

Turn On/Off run last setting function

DMX Connector Pin Assignment

The machine provide 3 or 5 pin XLR connector for DMX connection. Diagram below indicate pin assignment information

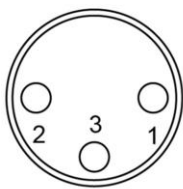

3 Pin XLR

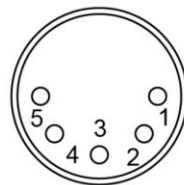
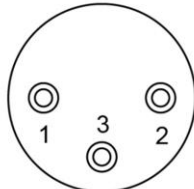

5 Pin XLR

Pin	Function
1	Ground
2	Data-
3	Data+

DMX Operation

Making the DMX Connection – Connect machine to a DMX controller or to one of the machines in the DMX chain. The machine uses an 3-pin XLR connector for DMX connection,

the connector is located on the rear of the machine.



Address Setup – Use control menu to set DMX address. The machine occupies 2 control channels. The starting address is defined as the first channel from which the machine will respond to the controller. Always double check to make sure there are no overlapping channels in order to control the machine correctly

DMX Channel Function

Channel 1	DMX Value Range	Function
Snow Output Level	0 – 5	Snow off
	6 – 255	Snow Output 1 – 100%
Channel 2	DMX Value Range	Function
Fan Output Level	0 – 5	Fan 20%
	6 – 255	Fan 21 – 100%

Wireless Remote Operation (Optional)

Wireless remote control system WTR-20 consist of a transmitter equipped with two buttons to activate, deactivate and adjust output level; with an onboard receiver attach to the front panel of S-500 snow machine.



SKU# WTR-20 Wireless Kit

Button	Function
[A]	Activate output
[B]	Deactivate output
[C]	Increase output level
[D]	Decrease output level

In a free open space the effective distance is 50 meters, actual usage depending on obstacle level the effective distance is 10-25 meters.

Registering a transmitter

Transmitter can be pair or deleted from the receiver. Each receiver can pair up to 10 transmitters. Follow below diagram to pair or delete transmitter.

IMPORTANT NOTE: *Wireless register menu will only be shown when Wireless is turn ON*
Transmitter battery replacement

If effective distance seems to be decreased, it is possible the battery level are low and require replacement. In order to replace the battery, undo the three screws on the back of transmitter to release the cover. Replace with same type and specification of battery which is 27A 12V.

Wired Remote Operation SKU# SC-3 (Optional)

Wire remote control module SC-3 enable to control the machine from a remote location. With three push button and two rotary knob to activate/deactivate, priming and output level adjustment.



Button/Knob	Function
[TOP LEFT KNOB]	Adjust pump output level
[TOP RIGHT KNOB]	Adjust blower output level
[LEFT BUTTON]	Max output on pump and blower
[CENTRE BUTTON]	Turn On/Off SC-3 remote
[RIGHT BUTTON]	Max output on blower

IMPORTANT NOTE:

[LEFT BUTTON] is meant for priming use, with a new tank of fluid or refill the fluid may not pump properly due to airlock in the pipeline, use this function to activate pump at maximum output, the [RIGHT BUTTON] is used when needed to clean out residue on the tip of output nozzle. Both of these button will overtake output adjustment knobs.

Physical Installation

Important

- Use supplied mounting bracket or rigging clamp to install nozzle.
- Mak sure installation location, fastening connecting, and rigging hardware can hold at least 10 times the weight of the nozzle.
- Make sure no combustibile or flammable material nearby.
- Secure nozzle with an approved safety cable that can hold at least 10 times the weight

of nozzle.

- Make sure nozzle installed in a well ventilated area.
- Consider nozzle replacement and routine maintenance access when selecting installation location.
- Connect fluid tank tubing before operation



Adjustable Mounting Bracket

Adjust mounting bracket by loosening screws, set the nozzle to desired angle and tighten the screw to finish adjustment. Illustration below demonstrates how to adjust mounting bracket.

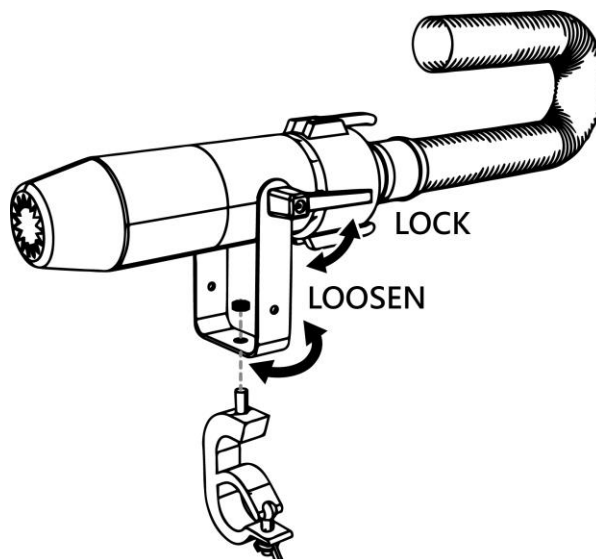

Mounting

Use screws for surface mounting or clamps for truss mounting.

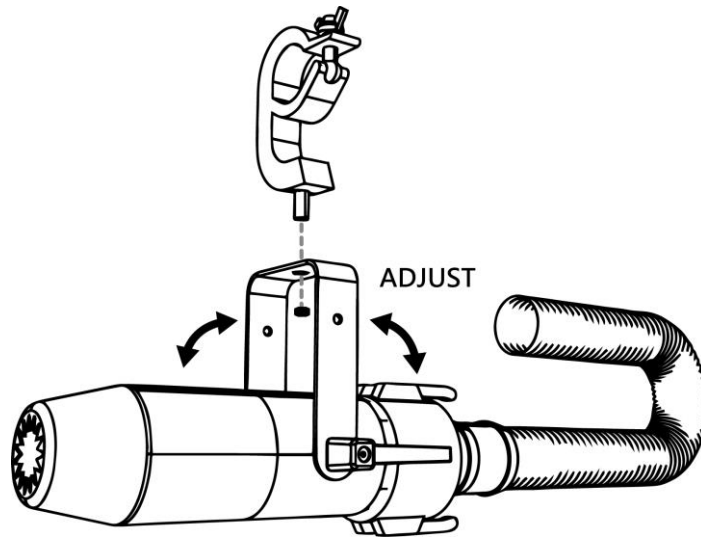

ST-10 Air Hose Extension (Optional)

The maximum air hose length is 20 meters. Illustration below demonstrates how to connect extension air hose

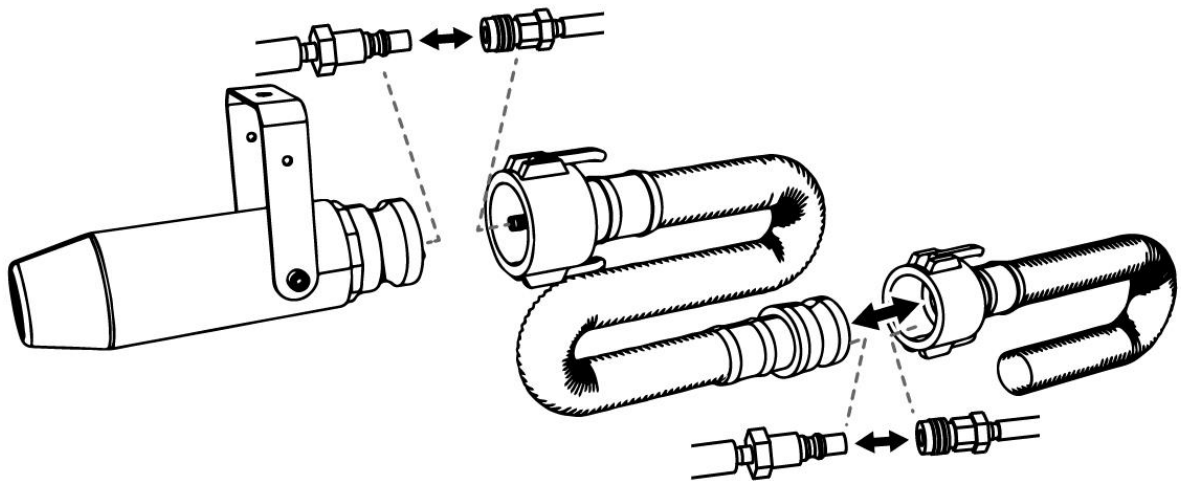

Fluid

Only use Antari SL-5A liquid for the S-500 Snow Machine. The machine is tested and calibrated with this liquid to get the best output performance. Warranty will be void if any other type of liquid is used, improper use of liquid may lead to machine failure and malfunction.

Service and Maintenance

- Do not allow the machine to become contaminated.
- Remove dust from air vents with air compressor, vacuum or a soft brush.
- Only use a damp cloth to clean the casing.
- Before storing run distilled water through the system to help avoid condensing the pump or heater.
- It is recommended to run the machine on a monthly basis in order to achieve best performance and output condition.
- Excessive dust, liquid and dirt built up will degrade performance and cause overheating.
- Before storing away after operation, pump pure water through the system for at least 1 to 2 minutes. This will help clean out the remaining snow fluid and prevent pump from malfunction on next usage.

Breaker Reset



Disconnect AC power before reset breaker. Only replace fuse with same type and rating.

Step 1: Disconnect power cord from supply.

Step 2: Flip breaker to ON position.

Step 3: Turn on machine to test.



Breaker

120V = 10A 250V

230V = 5A 250V

Technical Specifications

Input voltage	120V 60Hz 240V 50Hz
Breaker	120V = 10A 250V 230V = 5A 250V
Power consumption	890W
Max. operating time	0.8 hrs max. output
Fluid tank capacity	20L (5.28 gal)
Fluid consumption	400 ml/min.
Compatible fluid	Antari SL-5/SL-5A snow fluid
Control option	DMX 512, Cable remote, Manual, Wireless Adjustable snow volume and fan speed
DMX channels	2 channels, snow volume and fan speed
Power connection	Neutrik Powercon
DMX data connection	3-pin XLR and 5-pin XLR
Remote control connection	4-pin XLR
Dimension	L 592 x W 551 x H 651 mm (L 23.31 x W 21.69 x H 25.63 inch)
Dry weight	37.2 kg (82.01 lb)
Accessories (Optional)	SC-3 : Wired Remote ST-10 : 10 meter (32 feet) Air hose extension WTR-20 : Wireless Remote Kit PM-1 : Pan Motor W-DMX-PCBR : W-DMX Module



For current product information visit Antari at: www.antari.com
For information requests please contact us at: sales@antari.com



C08S50001

www.antari.com