

# MAC 250 Wash™

## user manual



**Martin**®

# Dimensions

All measurements are expressed in millimeters

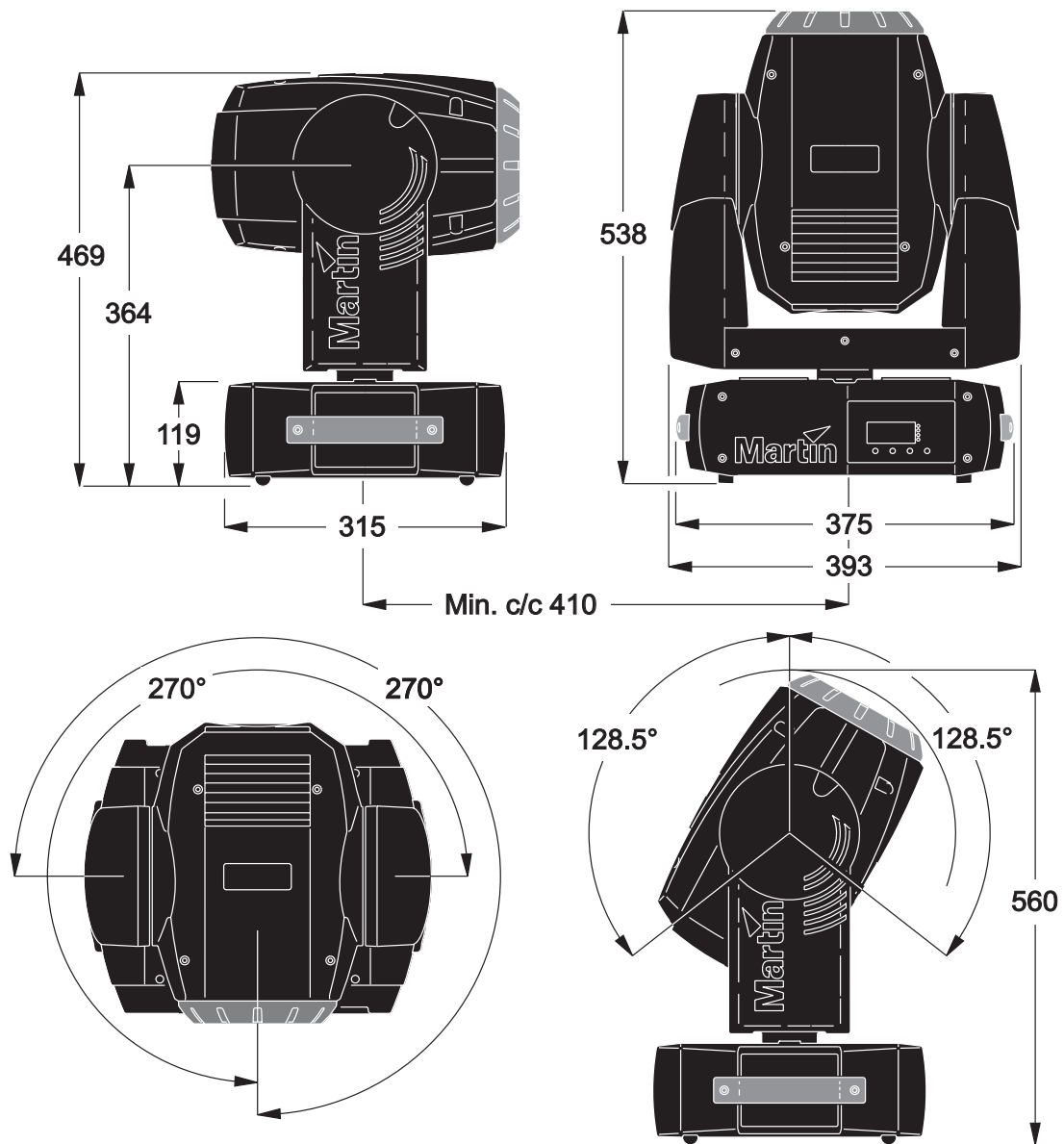

---

©2005-2010 Martin Professional A/S. Information subject to change without notice. Martin Professional A/S and all affiliated companies disclaim liability for any injury, damage, direct or indirect loss, consequential or economic loss or any other loss occasioned by the use of, inability to use or reliance on the information contained in this manual. The Martin logo, the Martin name and all other trademarks in this document pertaining to services or products by Martin Professional A/S or its affiliates and subsidiaries are trademarks owned or licensed by Martin Professional A/S or its affiliates or subsidiaries.

P/N 35000164 Rev. E

---

# Contents

Introduction .....	5
Features .....	5
Safety information .....	5
Setup .....	8
Unpacking .....	8
AC power .....	8
Installation .....	10
Connecting the DMX data link .....	11
Control panel .....	12
Menu navigation .....	12
DMX Address selection .....	12
16-bit and 16-bit Extended DMX Mode selection .....	12
Tailoring performance .....	12
Information readouts .....	14
Test and service utilities .....	14
Lamp power and reset shortcuts .....	16
LED signal readouts .....	16
DMX control .....	17
DMX operating modes .....	17
Lamp power .....	17
Effect position .....	17
Speed control .....	18
Optics .....	19
Color filters .....	19
Installing the wide-angle lens .....	21
Service .....	22
Cleaning guidelines .....	22
Lamp replacement .....	23
Cleaning procedure .....	24
Lubrication .....	25
Replacing fuses .....	25
Updating software .....	26
MAC 250 Beam Upgrade Kit .....	26
DMX protocol .....	27
Control menu .....	29
Adjustment submenu .....	32
Control panel shortcuts .....	32
Error messages .....	33
Troubleshooting .....	34
Circuit board connections .....	35
MAC 250 Wash™ Specifications .....	36
Appendix: MAC 250 Beam .....	41



#### **Disposing of this product**

Martin™ products are supplied in compliance with Directive 2002/96/EC of the European Parliament and of the Council of the European Union on WEEE (Waste Electrical and Electronic Equipment), as amended by Directive 2003/108/EC, where applicable.

Help preserve the environment! Ensure that this product is recycled at the end of its life. Your supplier can give details of local arrangements for the disposal of Martin products.

# Introduction

Thank you for selecting the Martin™ MAC 250 Wash™, a moving head wash light with a range of color-changing and control options and a 250 watt long-life discharge lamp. The MAC 250 Wash features a newly-designed glass reflector that gives extremely high light output.

## Features

The MAC 250 Wash features:

- efficient, 3000 hour, 250 watt discharge lamp
- full CMY color mixing
- color wheel with six removable dichroic color filters including CTC, plus open position
- combined dimmer/shutter with full-range dimming and variable speed pulse and strobe effects
- Fresnel lens plus optional wide-angle lens
- 540° of pan and 257° of tilt
- user-installable firmware
- switchable power supply setting
- tilt locks for easier transport and service
- temperature-regulated cooling fans for quieter operation

For the latest firmware updates, documentation, and other information about this and all Martin Professional products, please visit the Martin website at <http://www.martin.com>

Comments or suggestions regarding this document may be e-mailed to [service@martin.dk](mailto:service@martin.dk) or posted to:

Technical Documentation  
Martin Professional A/S  
Olof Palmes Allé 18  
DK-8200 Aarhus N  
Denmark

**Warning!** *Read the safety precautions in this manual before installing and operating the fixture.*

## Safety information

**Warning!** *This product is for professional use only. It is not for household or residential use.*

This product presents risks of lethal or severe injury due to fire and heat, electric shock, ultraviolet radiation, lamp explosion, and falls.

**Read this manual** before installing, powering or servicing the fixture, follow the safety precautions listed below and observe all warnings in this manual and printed on the fixture. If you have questions about how to operate the fixture safely, please contact your Martin supplier or call the Martin 24-hour service hotline on +45 8740 0000, or in the USA on 1-888-tech-180.

### PROTECTION FROM ELECTRIC SHOCK

**Warning!** *Always disconnect from mains supply before replacing the lamp.*

- Disconnect the fixture from AC power before removing or installing the lamp, fuses, or any part, and when not in use.
- Always ground (earth) the fixture electrically.

- Use only a source of AC power that complies with local building and electrical codes and has both overload and ground-fault (earth-fault) protection.
- Check that power supply settings match the local AC power before use.
- Before using the fixture, check that all power distribution equipment and cables are in perfect condition and rated for the current requirements of all connected devices.
- Isolate the fixture from power immediately if the power cable or power plug are in any way damaged, defective or wet, or if they show signs of overheating.
- Do not expose the fixture to rain or moisture.
- Refer any service operation not described in this manual to a qualified technician.

## **LAMP SAFETY**

- Prolonged exposure to an unshielded discharge lamp can cause eye and skin burns. Do not stare directly into the light output. Never look at an exposed lamp while it is lit.
- Do not operate the fixture with missing or damaged covers, shields, lenses or ultraviolet screens.
- A hot discharge lamp is under pressure and can explode without warning. Allow the fixture to cool for at least 45 minutes and protect yourself with safety glasses and gloves before handling a lamp or servicing the fixture internals.
- Replace the lamp immediately if it becomes visually deformed, damaged or in any way defective.
- Monitor hours of lamp use and lamp intensity and replace the lamp when it reaches the limit of its service life as specified in this manual or by the lamp manufacturer.
- Install only an approved lamp.
- If the quartz envelope of a discharge lamp is broken, the lamp releases a small quantity of mercury and other toxic gases. If a discharge lamp explodes in a confined area, evacuate the area and ventilate it thoroughly. Wear nitrile gloves when handling a broken discharge lamp. Treat broken or used discharge lamps as hazardous waste and send to a specialist for disposal.

## **PROTECTION FROM BURNS AND FIRE**

***Danger!*** ***Intense heat. Avoid contact by persons and materials.***

***The exterior of the fixture can get very hot – up to 160° C (320° F). Allow the fixture to cool for at least 45 minutes before handling.***

***Prolonged exposure to an unshielded lamp can cause eye and skin burns.***

- Never attempt to bypass the thermostatic switch or fuses. Always replace defective fuses with ones of the specified type and rating.
- Keep all combustible materials (for example fabric, wood, paper) at least 0.1 meter (4 inches) away from the fixture. Keep flammable materials well away from the fixture.
- Do not illuminate surfaces within 0.5 meters (20 inches) of the fixture.
- Provide a minimum clearance of 0.1 meters (4 inches) around fans and air vents.
- Do not modify the fixture in any way not described in this manual or install other than genuine Martin parts. Do not stick filters, masks or other materials onto any lens or other optical component. Use only Martin-approved accessories to mask or modify the light beam.
- Do not operate the fixture if the ambient temperature (Ta) exceeds 40° C (104° F).

## **PROTECTION FROM INJURY**

- Do not lift or carry the fixture alone.
- Use two evenly spaced clamps to suspend the fixture from rigging structures. Do not use only one clamp.
- When suspending the fixture, ensure that the supporting structure and all hardware used can hold at least 10 times the weight of all devices suspended from them.
- Do not use the handles in the base or the handles on the top of the yoke for hoisting or secondary attachment.
- Install as described in this manual a secondary attachment such as a safety cable that is approved by an official body such as TÜV as a safety attachment for the weight of all the fixtures it secures. The safety

cable must comply with EN 60598-2-17 Section 17.6.6 and be capable of bearing a static suspended load ten times the weight of the fixture.

- Check that all external covers and rigging hardware are securely fastened.
- Block access below the work area and work from a stable platform whenever installing, servicing or moving the fixture.

# Setup

## Unpacking

The MAC 250 Wash is supplied with:

- MSD 250/2 lamp (factory installed)
- 3-meter, 3-wire IEC power cable
- Wide-angle lens
- This user manual
- Two 1/4-turn T-brackets for mounting a clamp
- 5-meter, 3-pin shielded XLR control cable

The packing material or flightcase is carefully designed to protect the fixture during shipment - always use it to transport the fixture.

When installing the MAC 250 Wash, you may find it useful to lock the head in place using the tilt lock (see illustration).

For instructions on installing the wide-angle lens, see “*Installing the wide-angle lens*” on page 21.

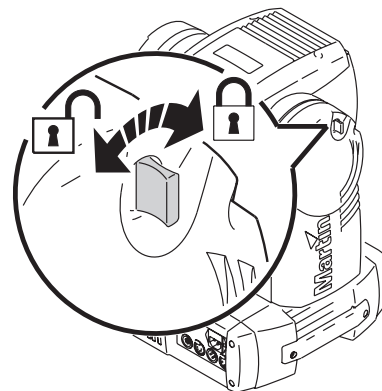

**Figure 1: Tilt lock**

## AC power

**Warning!** For protection from electric shock, the fixture must be grounded (earthed). The power supply must have both overload and ground-fault (earth-fault) protection.

**Important!** Check that power supply settings match the local AC power before use. The MAC 250 Wash is factory configured for 230 V / 50 Hz operation. If your AC power is different, the fixture must be configured for the local voltage and frequency. Always use the settings that are closest to your AC power. If no setting matches your local AC power exactly, select the next highest setting.



## CONFIGURING FOR LOCAL AC POWER

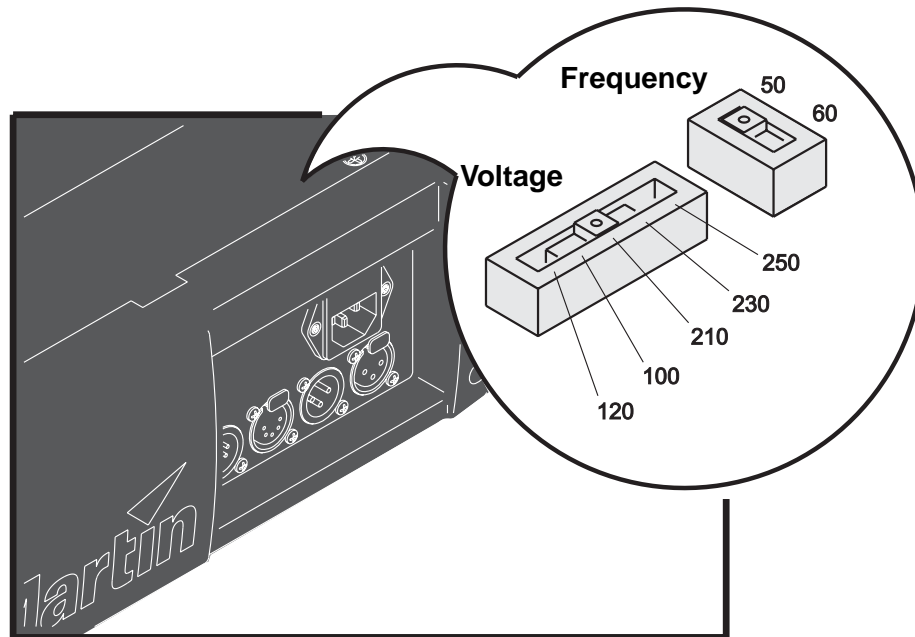

Figure 2: Power supply settings

1. Disconnect the fixture from power and allow to cool for at least 20 minutes.
2. Remove the 2 Phillips screws in the access cover directly behind the power and data connectors (see Figure 2). Lift off the cover.
3. Locate the selection switches.
4. Move the voltage switch to the setting that most closely matches the local AC voltage. If your voltage falls between 2 settings, select the higher voltage. For example, if your AC voltage is 220 V, use the 230 V setting instead of 210 V.
5. Move the frequency switch to the setting that matches the local AC frequency: 50 or 60 Hz.
6. Replace the cover.

The main fuse is suitable for all AC power voltages and frequencies accepted by the fixture and does not need to be replaced when the fixture's settings are changed.

## INSTALLING A PLUG ON THE POWER CABLE

The power cable must be fitted with a grounding-type cord cap (mains plug) that fits your power distribution system. Consult an electrician if you have any doubts about proper installation.

Following the cord cap manufacturer's instructions, connect the yellow and green wire to ground (earth), the brown wire to live, and the blue wire to neutral. The table below shows some pin identification schemes.

Wire	Pin	Marking	Screw color
brown	live	"L"	yellow or brass
blue	neutral	"N"	silver
yellow/green	ground		green

Table 1: Plug wiring

## APPLYING POWER

**Warning!** *All power cables must be undamaged and rated for the electrical requirements of all connected devices.*

**Important!** *Do not connect the MAC 250 Wash to a dimmer system, as this can damage the fixture.*

1. Check that the power supply cable is undamaged and rated for the current requirements of all connected devices.

2. Plug the prepared power cable into the AC input socket and a grounded (earthed) AC power outlet.

## Installation

### LOCATION AND ORIENTATION

The MAC 250 Wash may be installed in any orientation. It can be fastened directly to a suitable surface, hung with a rigging clamp, or placed directly on a level surface.

For safe operation, install the MAC 250 Wash in a location where:

- there are no flammable materials nearby
- the fixture is at least 0.1 meters (4 inches) away from combustible materials
- there is at least 0.1 meters (4 inches) clearance around the fan and control panel.
- all surfaces to be illuminated are at least 0.5 meters (20 inches) away.
- the fixture is protected from rain and moisture

### RIGGING OR MOUNTING THE MAC 250 WASH

**Warning!** *Block access below the work area before proceeding.*

The MAC 250 Wash can be placed on stage or clamped to a truss in any orientation. The Fast-Lock system enables quick and easy fastening of the clamp brackets in 4 positions.

The MAC 250 Wash is supplied with two T-brackets to which 1 or 2 rigging clamps (not included) can be bolted. The T-brackets fasten to the base with 1/4-turn fasteners as shown in Figure 3.

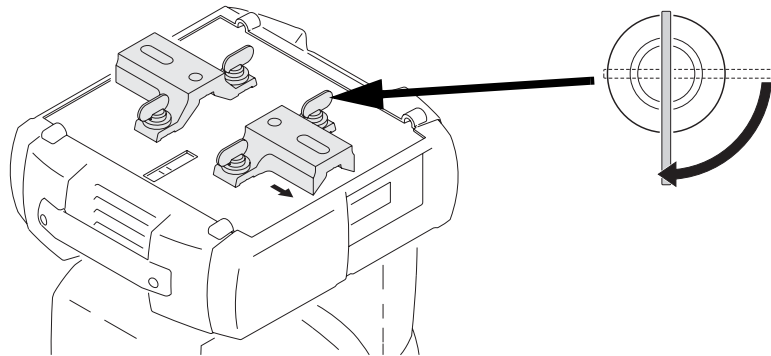

Figure 3: Clamp mounting bracket

**Warning!** *Attach an approved safety cable to the attachment point provided in the base. Never use the carrying handles for secondary attachment.*

*The 1/4-turn fasteners are locked only when turned fully clockwise.*

1. Check that the clamps are in perfect condition and can bear at least 10 times the weight of the fixture. Bolt clamps to the bracket with a grade 8.8 (minimum) M12 bolt and lock nut, or as recommended by the clamp manufacturer, through the 13 mm holes in the T-bracket.
2. Align the T-bracket with any 2 key slots on the base. Insert both locking pins into the slots and turn both levers on the quarter-turn fasteners a full 1/4 turn clockwise to lock.
3. Check that the structure can bear at least 10 times the weight of all installed fixtures, clamps, cables, auxiliary equipment, etc.
4. Working from a stable platform, clamp the fixture to the structure.

5. Install a safety cable that can bear at least 10 times the weight of the fixture securely to the structure and anchor the cable to the dedicated attachment point on the base. The attachment point is designed to fit a carabiner clamp.

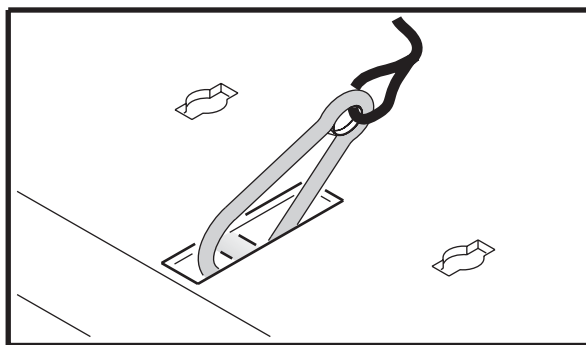

Figure 4: Safety cable attachment point

6. Check that there are no combustible materials or surfaces to be illuminated within 0.1 meter (4 inches) of the fixture, and that there are no flammable materials nearby.
7. Check that there is no possibility of heads or yokes colliding with other fixtures.

## Connecting the DMX data link

The MAC 250 Wash has locking 3-pin and 5-pin XLR data input and output sockets that are wired for use with standard DMX devices with pin 1 to shield, pin 2 to cold (-) and pin 3 to hot (+).

**Important!** *Never connect more than 1 data input and 1 data output to the fixture.*

1. Connect the controller's output to the fixture's data input.
2. Connect the output of the fixture closest to the controller to the input of the next fixture. If connecting a fixture with pin 3 hot to a fixture with reversed polarity (pin 3 cold), use a phase-reversing adaptor.
3. To terminate the link, insert a male 120 ohm XLR termination plug in the output of the last fixture.

3-pin to 3-pin phase-reversing adaptor	
Male	Female
1	1
2	3
3	2
P/N 11820006	

Male termination plug
Male XLR
1
2 $\text{---}$ 120 $\Omega$
3
P/N 91613017

### TIPS FOR BUILDING A DMX LINK

- Use shielded twisted-pair cable designed for RS-485 devices: standard microphone cable cannot transmit DMX data reliably over long runs. For links up to 300 meters (1000 ft.) long, you can use 24 AWG, low capacitance, 85-150 ohm characteristic impedance, shielded cable with 1 or more twisted pairs. For runs up to 500 meters (1640 ft.), use 22 AWG cable. Use an amplifier if the DMX link exceeds 500 meters.
- Fixtures must be connected in a single line. Never use a "Y" connector to split the link. To split the DMX link into branches, use a splitter such as the Martin 4-Channel Opto-Isolated RS-485 Splitter/Amplifier.
- Do not overload the link. Up to 32 devices may be connected on a DMX link.
- Terminate the link by installing a termination plug in the output socket of the last fixture on the link. The termination plug is a male XLR connector with a 120 ohm, 0.25 watt resistor soldered between pins 2 and 3. This "soaks up" the control signal so it does not reflect back down the link and cause interference. If a splitter is used, terminate each branch of the link.

# Control panel

You can set the MAC 250 Wash's DMX address, configure individual fixture settings (personality), read out data, and execute service utilities from the MAC 250 Wash's control panel. Settings can also be changed remotely via the DMX link with the Martin MP-2 uploader.

See also the control menu overview starting on page 29.

## Menu navigation

The DMX address and any error messages are displayed after the fixture resets. To enter the menu, press [Menu]. Use the [Up] and [Down] keys to move within the menu. To select a function or submenu, press [Enter]. To escape a function or menu, press [Menu].

## DMX Address selection

For independent control, each fixture must be assigned its own unique address and control channels. Two fixtures can share the same address if they are to respond identically: they will receive the same instructions and individual control will not be possible.

Two fixtures can be set up so that one pans as a mirror image of the other. To achieve this, assign the same DMX address to both fixtures, but use the settings in the control menu to invert the pan on one fixture (see "*Movement*" below).

### SETTING THE DMX ADDRESS

1. Apply power to the MAC 250 Wash. Press [Menu] to enter the main menu.
2. Select **ADDR** using the [Up] and [Down] keys. Press [Enter].
3. Select an address (start channel) from 1 to 500 (for 16-bit mode) or 1 to 494 (for 16-bit Extended mode) using the [Up] and [Down] keys. Press [Enter]. Press [Menu] to return to the main menu.

## 16-bit and 16-bit Extended DMX Mode selection

The MAC 250 Wash has two DMX operating modes, 16-bit and 16-bit Extended. 16-bit mode uses 13 DMX channels and 16-bit Extended mode uses 19 DMX channels. 16-bit Extended mode provides more precise control of the dimmer, CMY color mixing, color filter, and frost effects. The MAC 250 Wash is supplied in 16-bit mode by default. DMX mode is changed using the **PSET** option in the fixture control menu (see "*Control menu*" on page 29).

### SETTING THE DMX MODE

1. Apply power to the MAC 250 Wash. Press [Menu] to enter the main menu.
2. Select **PSET** using the [Up] and [Down] keys. Press [Enter].
3. Select **16BT** for standard 16-bit mode, or **16EX** for 16-bit Extended mode. Press [Enter].
4. Press [Menu] to return to the main menu.

## Tailoring performance

### MOVEMENT

The MAC 250 Wash provides various options for optimizing movement to suit different applications.

- **PATI**, the pan and tilt invert menu, allows you to swap the pan and tilt channels (**SWAP**→**ON**), invert pan movement (**PINV**→**ON**), and invert tilt movement (**TINV**→**ON**). These options can be useful in situations where you want some fixtures to mirror the performance of others with the same DMX address, or when fixtures are not oriented as programmed.
- **PTSP**, the pan/tilt speed menu, provides 2 settings: **FAST** and **NORM** (normal). The **FAST** setting provides maximum speed on controllers with high DMX output refresh rates (e.g. a recent PC and Martin LightJockey software). The **NORM** setting gives smoother, more precise movement with less powerful DMX controllers as well as the option of longer fade times, for theater use for example. Pan/tilt speed is set to **FAST** by default.
- **EFSP**, the effects speed menu, provides 3 settings: **FAST**, **NORM** and **PTSS** (Pan Tilt Speed Slave). The **FAST** and **NORM** settings are similar to **PTSP** (see above). If set to **PTSS**, effects speed copies the pan/tilt speed setting. This lets you set effects speed and pan/tilt speed with one instruction from your DMX controller.
- In the **PERS** (personality) menu, **SCUT** determines whether the color and gobo wheels scroll past open when changing positions. When set to **ON**, the wheels can “take a shortcut” and scroll through open when this is the shortest path to the next position. The wheels do not scroll past open when **SCUT** is set to **OFF**.

## DISPLAY

The display menu (**PERS**→**DISP**) determines whether the display remains lit or not. Select **ON** to have the display remain permanently lit, Select **2 MN** or **10MN** to extinguish the display two minutes or ten minutes after the last key press.

To turn the display upside-down for easier reading, press [Up] and [Down] simultaneously.

The display intensity setting (**PERS**→**INT**) controls display brightness. You can select **AUTO** for automatic dimming of the display using the built-in light sensor, or manually select an intensity level from 10 to 100.

## LAMP POWER

There are two settings that modify lamp control: Automatic Lamp On (**PERS**→**ALON**) and DMX Lamp-Off (**PERS**→**LLOF**).

There are three options for automatic lamp control: **ON**, **OFF**, and **DMX**. When **ALON** is **OFF**, the lamp remains off until a lamp-on command is received from the controller. When **ALON** is **ON**, the lamp strikes automatically after the fixture is powered on. When **ALON** is set to **DMX**, the lamp strikes automatically when the fixture receives DMX data, and it douses automatically after 15 minutes without receiving DMX data. When **ALON** is set to either **ON** or **DMX**, lamp strike timing is determined by the fixture address to prevent all lamps from striking at once.

The DMX lamp-off setting affects how the lamp can be doused. When **LLOF** is **ON**, lamp power can be switched off by sending a DMX value from 248 to 255 on channel 1 for five seconds. When **LLOF** is **OFF**, the lamp-off command will not work unless special conditions are met (see the DMX protocol on page 27 for more details).

## RESET

The fixture can be reset instantly from the controller if DMX reset (**PERS**→**RES**) is set to **ON**. The reset value must be held for 5 seconds to reset if DMX reset is set to **5SEC**. If DMX reset is **OFF**, resetting the fixture via DMX will not work unless special conditions are met. Refer to the DMX protocol.

## DIMMER CURVE

In **PERS**→**DICU**, the dimmer can be set up to either open and close in a linear manner (**DIM1**) or emulate the characteristics of a tungsten incandescent bulb (**DIM2**).

## STUDIO MODE

If **PERS**→**STUD** is set to **ON**, pan, tilt and effects movement speed is set to **NORM** (normal) and fans are set to **REG** (temperature regulated operation) to give the quietest possible operation. Any existing speed

settings are overridden. The message *SET BY STUDIO MODE* scrolls in the display if you try to change speed settings via the *PTSP* or *EFSF* control options.

### CMY BLACKOUT

- *CMY B* (CMY blackout) in the *PERS* menu makes the shutter blackout more effective. When set to *ON*, the CMY flags are activated 3 seconds after the shutter is closed. This absorbs any light output that escapes past the shutter. The CMY flags open automatically when the shutter is opened. Since this takes a fraction of a second longer, set *CMY B* to *OFF* for fastest snap open from blackout.

### DEFAULT AND CUSTOM SETTINGS

The fixture can be reset to its factory default settings by selecting *DFSE→FACT→LOAD*.

Up to 3 custom settings can be saved and recalled. For example, to save custom setting 1, configure the fixture as desired, then select *DFSE→CUS 1→SAVE*. To recall this setting, select *DFSE→CUS 1→LOAD*.

## Information readouts

### POWER-ON HOURS

This readout can be used to track maintenance intervals. Read the total number of hours the fixture has been on since fabrication in *INFO→TIME→HRS→TOTL*, pressing [Enter] to display. Read the number of hours since the counter was last reset in *INFO→TIME→HRS→RSET*. Press [Enter] to display, and press [Up] for 5 seconds while displayed to reset.

### LAMP HOURS

Read the total number of lamp hours since fabrication in *INFO→TIME→L HR→TOTL*, and the number of lamp hours since the counter was last reset in *INFO→TIME→L HR→RSET*. Reset this counter after installing a new lamp. Press [Up] for 5 seconds while displayed to reset.

### LAMP STRIKES

Read the total number of lamp strikes in *INFO→TIME→L ST→TOTL*, and the number of lamp strikes since the counter was last reset in *INFO→TIME→L ST→RSET*. Reset this counter when installing a new lamp. Press [Up] for 5 seconds while displayed to reset.

### TEMPERATURE READOUTS

The temperature of the head can be read via *INFO→TEMP→HEAD* and the temperature of the base unit can be read via *INFO→TEMP→BASE*. Temperatures are in degrees Celsius.

### FIRMWARE VERSION

*INFO→VERS* displays the firmware version number. The firmware version is also displayed briefly at startup.

## Test and service utilities

### DMX READOUT

The DMX log (*DMXL*) menu provides useful information for troubleshooting control problems.

*RATE* displays the DMX refresh rate in packets per second. Values lower than 10 or higher than 44 may result in erratic performance, especially when using tracking control.

*QUAL* displays the quality of the received DMX data as a percentage of packets received. Values much below 100 indicate interference, poor connections, or other problems with the DMX data link that are the most common cause of control problems.

**STCO** displays the DMX start code. Packets with a start code other than 0 may cause irregular performance.

The remaining readouts under **DMXL** display the DMX values received on each of the 13 channels available in both 16-bit and 16-bit Extended modes, from **SHUT** (shutter, channel 1) to **EFSP** (effect speed, channel 13). If the fixture does not behave as expected, reading the DMX values can help you troubleshoot the problem.

## MANUAL CONTROL

The manual control menu (**MAN**) provides commands for resetting the fixture (**RST**), as well as striking the lamp (**L ON**), and dousing the lamp (**L OFF**). It also permits you to position and move individual effects.

## EFFECTS TEST

The test sequence (**TSEQ**→**RUN**) runs through all effects to provide a quick check of fixture performance. Press [Menu] to stop the test.

## FEEDBACK TOGGLE

Note that [Enter] must be pressed for 3 seconds to access settings in the **UTIL** menu.

Sensors monitor the positions of the pan/tilt systems and color wheel. If they detect an error, the effect resets on the fly. The shutter closes during resetting.

To ease service, for example, this feature can be disabled for pan/tilt by turning pan/tilt feedback off (**UTIL**→**FEBA**→**OFF**). The disabled pan/tilt feedback setting is saved when you exit the **UTIL**→**FEBA** menu.

Color wheel feedback can also be turned off (**UTIL**→**EFFB**→**OFF**). This setting is also saved when you exit the **UTIL**→**EFFB** menu.

## ADJUSTMENT POSITIONS

The adjustment menu (**UTIL**→**ADJ**) provides commands for positioning the head and effects, as well as an effects position test sequence, during service and mechanical adjustment (see “*Adjustment submenu*” on page 32).

If the test sequence is run by selecting **UTIL**→**ADJ**→**HEAD**→**TEST** and an error is detected, the test aborts and a number flashes in the display to indicate which effect is out of position. Note this number and contact your Martin service center for advice.

## EFFECT CALIBRATION

With the calibration menu (**UTIL**→**CAL**), effect positions can be fine-tuned with a software-defined offset value to compensate for small misalignments or differences between fixtures.

The default offset command (**UTIL**→**DFDF**) erases any offsets stored in memory.

## CIRCUIT BOARD TEST

**UTIL**→**PCBT** executes a routine designed for testing the main circuit board. This function is for service use only.

## FAN CONTROL

In **UTIL**→**FANS**, the cooling fans can be set to run at full speed or set to thermostatically regulated control. Running at full speed will give maximum lamp and component service life. Running at regulated speed gives quietest operation.

## UPLOAD MODE

The upload mode command (**UTIL**→**UPLD**) prepares the fixture for a software update.

## Lamp power and reset shortcuts

The control panel buttons can be used to control lamp power and reset the fixture.

- To strike the lamp, press [Enter] and [Up].
- To douse the lamp, press [Enter] and [Down].
- To reset the fixture, press [Menu] and [Up].

## LED signal readouts

Four LEDs next to the digital display give additional information about fixture status:

- Ready: fixture is ready for operation.
- DMX: fixture is receiving a valid DMX signal.
- Lamp: lamp is struck and lit.
- Service: fixture is in service mode (for service use only).



# DMX control

The MAC 250 Wash is compatible with USITT DMX 512 controllers and can be added to a standard DMX data link.

This section briefly describes the DMX-controllable effects. See “*DMX protocol*” on page 27 for an overview of DMX control options.

## DMX operating modes

The MAC 250 Wash has two DMX operating modes, 16-bit and 16-bit Extended. 16-bit mode uses 13 DMX channels and 16-bit Extended mode uses 19 DMX channels. 16-bit Extended mode provides more precise control of the dimmer, CMY mix, color filter and frost settings. All other functions are identical. The DMX mode is selected using the *PSET* option in the fixture’s control panel (see “*Control menu*” on page 29).

## Lamp power

### LAMP-ON

Unless automatic lamp strike is enabled, lamp power remains off until a lamp-on command is sent from the controller.

Note: A peak of electric current that can be many times the operating current is drawn for an instant when striking a discharge lamp. Striking many lamps at once may cause a voltage drop large enough to prevent lamps from striking or draw enough current to trip circuit breakers. If sending lamp-on commands to multiple fixtures, program a sequence that strikes lamps one at a time at 5 second intervals.

### LAMP-OFF

The lamp can be doused from the controller by sending the lamp-off command on channel 1 for 5 seconds.

**Important!** *Once a lamp is doused, it cannot be restruck until it has cooled. This typically takes around 8 minutes.*

Note that the lamp-off command may be disabled using the DMX Lamp-Off personality setting (*PERS*→*LDL*) in the fixture’s control panel.

## Effect position

### RESET

If an effect loses its indexing and fails to move to programmed positions, the fixture can be reset from the controller by sending the “Reset” command on channel 1. Note that you can require a DMX reset command to be sent for 5 seconds before it is executed, or you can disable the DMX reset feature, using the DMX Reset personality setting (*PERS*→*JRES*) in the fixture’s control panel.

### DIMMER / SHUTTER

The mechanical dimmer/shutter system provides full high-resolution dimming, “instant” open and blackout, random and variable strobe effects, and random and variable pulses in which the dimmer snaps open and slowly dims or snaps closed and slowly opens. Shutter, strobe, and pulse effects are selected on channel 1. The intensity level is selected on channel 2. 16-bit Extended mode provides fine tuning of the intensity level on channel 3.

## COLOR

The color wheel can be scrolled continuously – allowing for split color effects – or in steps, and rotated randomly or continuously in both directions at different speeds. In 16-bit Extended mode, the color setting selected on channel 10 can be fine-tuned on channel 11.

## PAN AND TILT

Head pan and tilt are controlled on channels:

- 8 - 11 in 16-bit mode
- 14 - 17 in 16-bit Extended mode

The main pan and tilt control channels set the first 8 bits (the most significant byte or MSB), and the fine channels set the second 8 bits (the least significant byte or LSB) of the 16-bit control byte. In other words, the fine channels fine-tune the positions set by the main channels.

## Speed control

Speed of pan, tilt and effects is controlled on channels:

- 12 and 13 in 16-bit mode
- 18 and 19 in 16-bit Extended mode

## TRACKING CONTROL

Tracking control for pan/tilt and the various effects is enabled by setting the speed channels to 0.

With tracking control, the speed at which effects fade from one scene or position to the next (cross-fade speed) is determined by the controller. The controller divides the move into steps and updates the fixture with small changes at the rate required to achieve the fade. The fixture “tracks” the changes and averages them with a digital filter algorithm to provide smooth movement.

## VECTOR CONTROL

Alternatively, with vector control, effects movement speed is determined by the values selected on the speed channels. This makes it possible to modify the speed of cross-fades when using a controller that does not offer cross-fade speed control. Vector control also provides smoother movement, particularly at slow speeds, with controllers that send slow or irregular tracking updates.

When using vector control, the cross-fade time on the controller must be set to 0.

## BLACKOUT

When “blackout while moving” is selected on the speed channels, the shutter closes when the effect moves to make the transition invisible. The shutter opens when the movement is complete.

## PERSONALITY OVERRIDES

The following channels provide tracking values that allow you to override the pan/tilt speed personality setting (*PTSP* in the control menu)

- 12 in 16-bit mode
- 18 in 16-bit Extended mode

The following channels provide tracking values that allow you to override the shortcuts setting (*PERS*→*SCUT* in the control menu).

- 13 in 16-bit mode
- 19 in 16-bit Extended mode

# Optics

## Color filters

### STANDARD CONFIGURATION

The MAC 250 Wash provides 6 dichroic color filters as shown below.

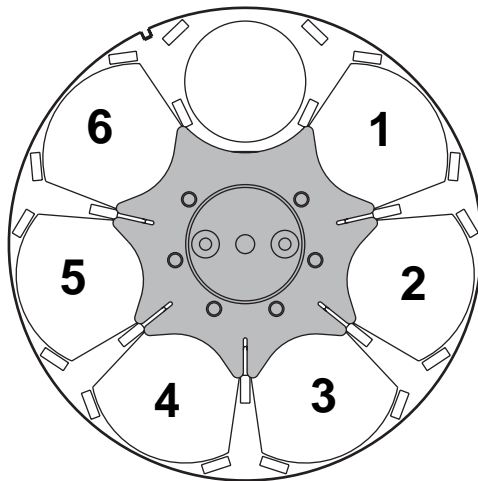

Position	Color
1	CTC 5500 - 2900 K
2	Pink 312
3	UV
4	Red 308
5	Green 206
6	Blue 108

Table 2: Standard colors

Figure 5: Color wheel (viewed from lamp side)

### REPLACING A COLOR FILTER

**Danger!** *Intense heat. Avoid contact by persons and materials. The exterior of the fixture can get very hot – up to 160° C (320° F). Disconnect the fixture from AC power and allow it to cool for at least 45 minutes before handling.*

*Do not remove covers while the fixture is powered on as this exposes dangerous live electrical circuits, hot surfaces, and a lamp under high pressure.*

1. Disconnect the fixture from AC power and allow it to cool.
2. The top and bottom covers look the same, but the top cover can be identified by checking that the text on the back of the head is oriented correctly as illustrated in Figure 6. Remove the top cover using a flathead screwdriver to loosen the four quarter-turn screws.

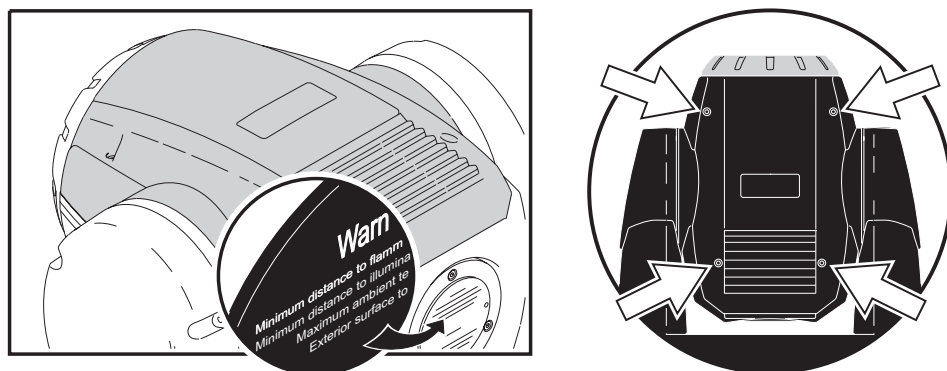
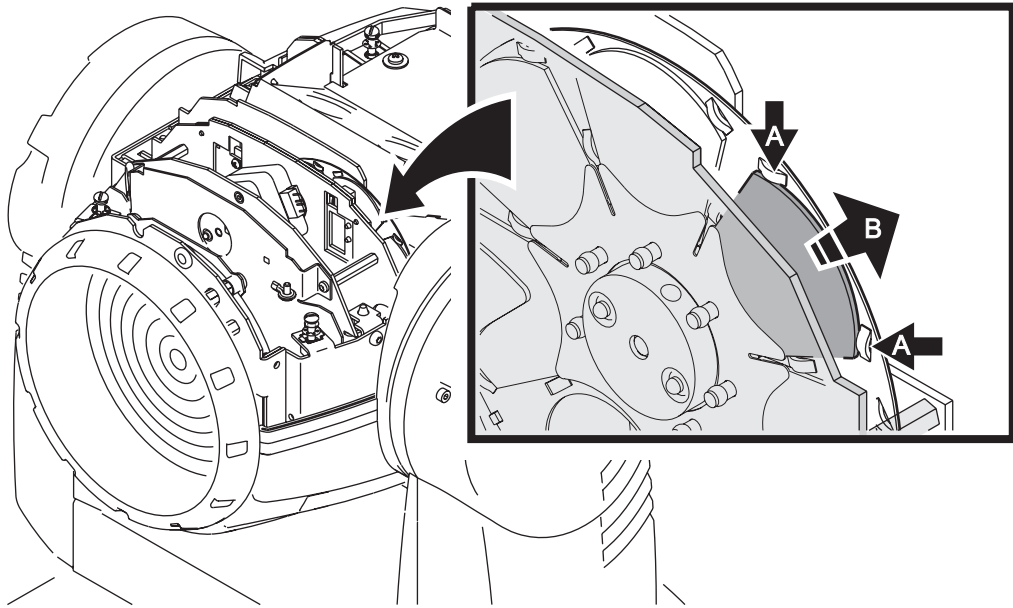

Figure 6: Identifying and removing the upper head cover

- Put on clean lint-free gloves or use a clean lint-free cloth to avoid having to clean filters after handling.
- Turn the color wheel to access the desired color filter. Press the filter away from the wheel slightly to release it from the retaining lugs (A) and then lift it out of the wheel (B) – see Figure 7.



**Figure 7: Color filter replacement**

- Color filters must be installed with the coated side facing towards the lamp as in Figure 8. To insert a color filter, slide it under the retention spring until it locates securely behind the lugs (A) on the color wheel. Clean the filter if necessary to ensure that it is perfectly free of oil or grease.

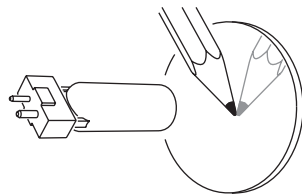

**Coated side towards lamp**

When an object is held up to the coated side, there is no space between the object and its reflection. The back edge of the filter cannot be seen when looking through the coated side.

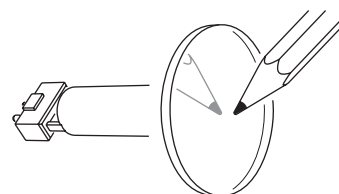

**Uncoated side away from lamp**

When an object is held up to the uncoated side, there is a space between the object and its reflection. The back edge of the filter can be seen when looking through the uncoated side.

**Figure 8: Correct color filter orientation**

- Replace the top cover before applying power.

## Installing the wide-angle lens

A 61.5° cutoff-angle wide-angle lens is supplied with the MAC 250 Wash, together with all items necessary to install it.

To install the wide-angle lens:

1. Disconnect the fixture from power and allow it to cool.
2. Set the tilt lock and remove top and bottom head covers.
3. See Figure 9. Prepare to hold the front lens assembly as it is released, then remove the four retaining screws and remove the assembly.
4. See Figure 10. Place the front lens assembly face down on a work surface. Remove the 4 screws from the lens clamps, then remove the clamps (A), the standard lens (B) and the 4 silicone tubes (C) from the lensholder ring (D).
5. Reassemble using the same screws but replacing the standard clamps, silicone tubes and lens with the extra items supplied with the MAC 250 Wash.

Note that the smooth side of the lens must face towards the lamp, as shown in Figure 10. Make sure that the lens is centered and sits flat on the lensholder ring (D). Tighten screws enough to compress the silicone tubes and hold the lens firmly, as shown in Figure 11.

6. Reinstall the lens assembly in the head, reinstall the covers and release the tilt lock before applying power.

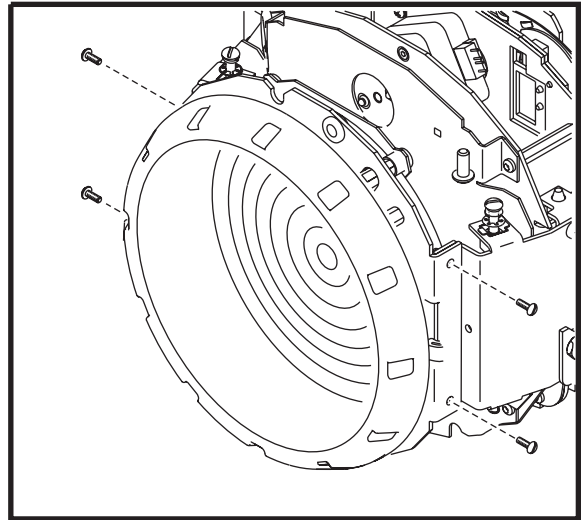

Figure 9: Removing the front lens

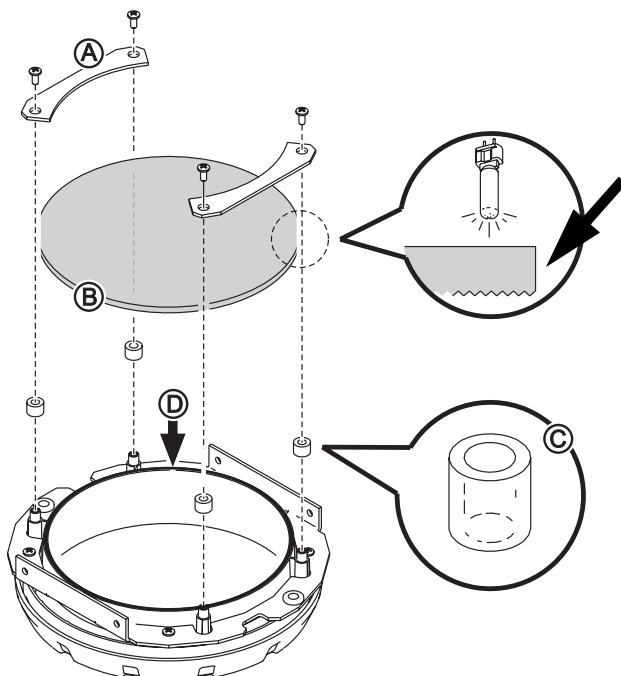

Figure 10: Lens retaining assembly

The textured side of the lens must face away from the lamp.

The lens must seat squarely in the lens ring (D). Tighten screws enough to compress the silicone tubes and hold the lens firmly.

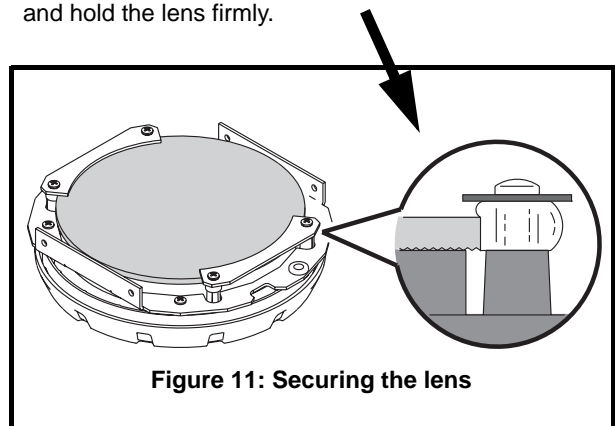

Figure 11: Securing the lens

# Service

**Warning!** Read “Safety information” on page 5 before servicing the MAC 250 Wash. Disconnect the fixture from power and allow to cool for 45 minutes before handling or removing any cover. Refer any service operation not described here to a qualified service technician.

**Intense heat. Avoid contact by persons and materials. The exterior of the fixture can get very hot – up to 160° C (320° F). Disconnect the fixture from AC power and allow it to cool for at least 45 minutes before handling.**

**Do not remove covers while the fixture is powered on, as this exposes dangerous live electrical circuits, hot surfaces, and a lamp under high pressure.**

The MAC 250 Wash requires regular maintenance to maintain peak performance.

It is Martin policy to use the best-quality materials and coatings available to ensure optimum performance and the longest possible component lifetimes. However, optical components in all lighting fixtures are subject to wear and tear over the life of the fixture, resulting in gradual changes in color rendition of dichroic filters or the specular properties of reflectors, for example.

The extent of wear and tear depends heavily on operating conditions, maintenance and environment, so it is impossible to specify precise lifetimes for optical components. However, you will eventually need to replace optical components if their characteristics are affected by wear and tear after an extended period of use and if you require fixtures to perform within very precise optical and color parameters.

As with electronic components in general, the MAC 250 Wash’s PCBs are sensitive to ESD (electrostatic discharge). Take precautions to avoid ESD damage before opening the fixture. Service electronic components at a static-safe workstation only.

## Cleaning guidelines

**Important!** Excessive dust, smoke fluid, and particle buildup degrades performance, causes overheating and will damage the fixture. Damage caused by inadequate cleaning or maintenance is not covered by the product warranty. To maximize the life of the MAC 250 Wash and protect the investment it represents, clean the fixture regularly – especially the cooling systems – following the guidelines in this section.

Cleaning is vital. Excessive dust, grease, and smoke fluid buildup will degrade performance and cause overheating and damage that is not covered by the warranty. Cleaning schedules for lighting fixtures vary greatly depending on the operating environment. Cooling fans suck in airborne dust and smoke particles, and in extreme cases fixtures may require cleaning in less than 50 hours of operation. Environmental factors that may result in a need for frequent cleaning include:

- Use of smoke or fog machines.
- High airflow rates (near air conditioning vents, for example).
- Presence of cigarette smoke.
- Airborne dust (from stage effects, building structures and fittings or the natural environment, for example).

If one or more of these factors is present, inspect fixtures within their first 25 hours of operation to see whether cleaning is necessary. Check again at frequent intervals. This procedure will allow you to assess cleaning requirements in your particular situation. If in doubt, consult your Martin dealer about a suitable maintenance schedule.

## Lamp replacement

Lamp life will vary. The rated life of a lamp is the average operating life before lamp failure in the manufacturer's test cycle. To reduce the risk of lamp explosion that will almost certainly damage the fixture, replace the lamp when it reaches the limit of its rated life. Never exceed a long-life lamp's rated life (3000 hours for the Philips MSD 250/2) by more than 10 percent.

For maximum lamp life, avoid excessive strikes and always allow the lamp to burn for at least 5 minutes before dousing it.

Replace the lamp when:

- it strikes with difficulty or not at all, is visibly deformed or is in any other way defective
- hours of use reach the manufacturer's "replace before" limit. See Table 3.

### COMPATIBLE LAMPS

The MAC 250 Wash is supplied with a Philips MSD 250/2 lamp installed. Approved lamp options are shown in the table below. *Installing any other lamp may damage the fixture.*

Lamp	Average life	Color Temp.
Philips MSD 250/2	3000 hr	8500 K
Osram HSD 250/78	3000 hr	7800 K
GE CSD 250/2	3000 hr	9000 K

Table 3: Lamp comparison

### INSTALLING A LAMP

**Danger!** *Intense heat. Avoid contact by persons and materials. The exterior of the fixture can get very hot – up to 160° C (320° F). When replacing the lamp, disconnect the fixture from AC power and allow it to cool for at least 45 minutes before proceeding. Protect eyes and hands with safety goggles and gloves.*

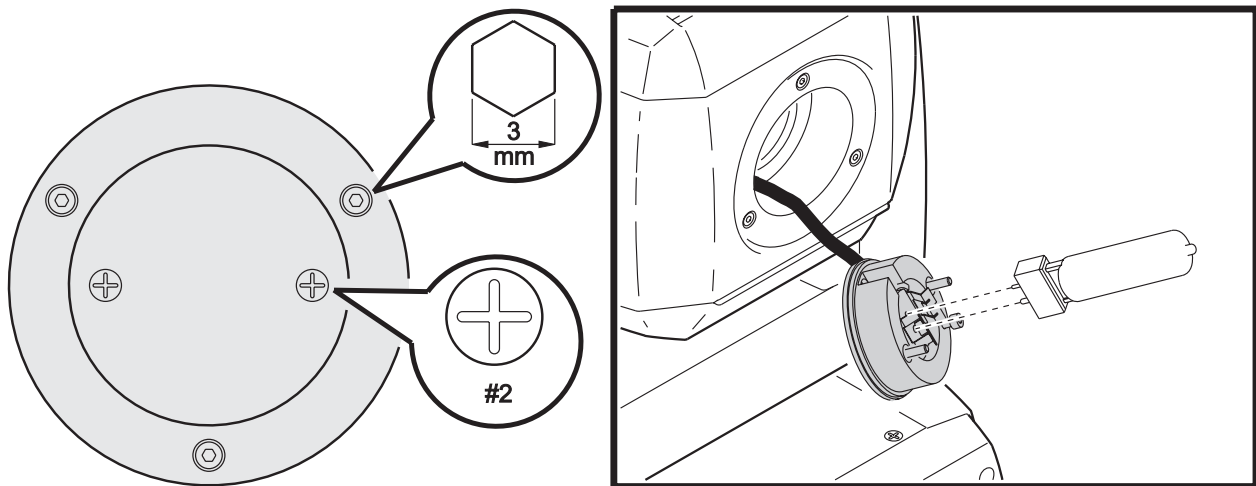

Figure 12: Lamp installation

1. Locate the lamp access cover at the back of the fixture head and remove the two Phillips screws.
2. Pull out the lamp socket.
3. If changing the lamp, remove the old lamp from the socket.
4. Holding the new lamp by its ceramic base (do not touch the glass), align the small pins on the lamp with the small holes in the socket and insert the lamp squarely. Make sure that the 4 small projections on the base contact the face of the socket.
5. Clean the glass bulb with the cloth supplied with the lamp, particularly if your fingers touched the glass. A clean, lint-free cloth wetted with alcohol may also be used.
6. Insert the lamp into the fixture with as little twist in the lamp wires as possible.

7. Align the screw holes and fasten the lamp access plate with 2 screws.
8. If installing a new lamp, reset the lamp hour and lamp strike counters as described on page 14.
9. Strike the lamp and adjust for optimum performance by turning the three 3mm Allen screws shown in Figure 12 one at a time until the brightest part of the beam is centered.
10. A hot-spot can be adjusted out with the three Allen screws. Turn the screws an equal amount to maintain lamp alignment.

## Cleaning procedure

Use care when cleaning. The surface on dichroic filters is achieved by means of special multi-layer coatings and even small scratches may be visible. Residues from cleaning fluids can bake onto components and ruin them.

Remove smoke and other residues with cotton swabs or unscented tissues wetted with isopropyl alcohol 99.9%. A commercial glass cleaner may be used, but residues must be removed with distilled water. Clean with a slow circular motion from center to edge. Remove stuck particles with an unscented tissue or cotton swab soaked in alcohol. Do not rub the surface: lift particles off with a soft repeated press.

Rinse with distilled water. Mixing the water with a small amount of wetting agent such as Kodak Photoflo will help prevent streaking and spotting.

To clean the MAC 250 Wash:

1. Disconnect the fixture from power and allow the components to cool completely.
2. Use a vacuum and soft brush to remove any dust from the outside of the fixture and air vents.
3. Remove the head covers using a flathead screwdriver to loosen the four quarter-turn screws.
4. Release the air filter from the lower cover by hooking a fingertip under the edge of its clip and pulling up.
5. Clean the air filter with a vacuum or compressed air. If the filter is contaminated with smoke residue or other oily substances, soak and squeeze clean in a warm water/detergent solution, then blot dry. If the filter is not in perfect condition, replace with a new item, available from your Martin dealer.
6. Clean the twin fans in the head (see Figure 13) and the air vents in the head covers with a soft brush or cotton swab and vacuum.

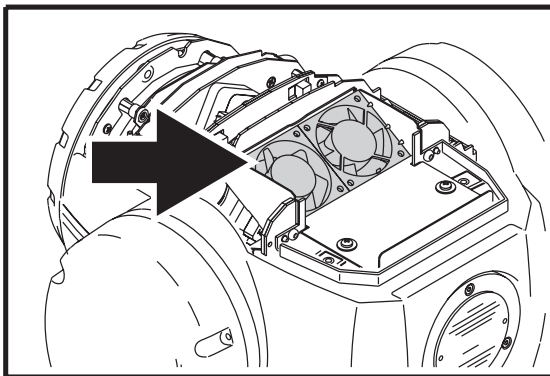

**Figure 13: Head fans**

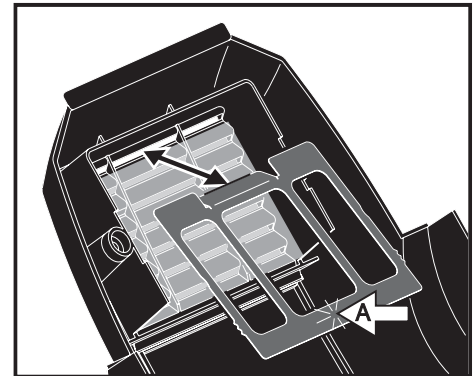

**Figure 14: Refitting the air filter**

7. Refit the air filter in the lower head cover by placing the filter in position, then hooking the tab on the filter clip under the last louver in the air vent and pressing the clip down onto the filter with a fingertip on (A) until secure (see Figure 14).
8. Carefully clean the optical components.
9. Dry with a clean, soft, lint-free cloth or compressed air.
10. Refit the head covers.

**Important!** *The head cover with the air filter must be fitted over the head fans so that filtered air is sucked into the fixture.*



11. Remove the two 4mm Allen screws from the carrying handles on the sides of the base unit and remove the louvered side covers. Clean the cover louvers and base fan with a cotton swab or soft brush and vacuum.
12. Refit the base unit covers before reapplying power.

## Lubrication

The MAC 250 Wash requires no lubrication under normal circumstances. Moving parts are treated with a long-lasting Teflon-based lubricant that can be reapplied by a Martin service partner in the unlikely event that this should be necessary.

## Replacing fuses

### MAIN FUSE

The main fuse holder is built into the mains input socket.

**Warning!** *Always replace the fuse with one of the same type and rating!*

To replace the main fuse:

1. Unplug the mains cable from the input socket.
2. Pry open the fuse holder and remove the fuse.
3. Replace the fuse with one of the same type and rating. The fuse rating is listed on the serial number label.
4. Close the fuse holder and replace the mains cable.

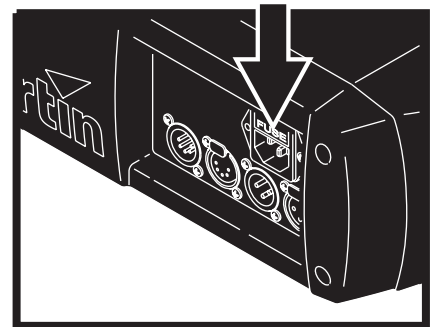

**Figure 15: Main fuse holder**

### POWER SUPPLY FUSES

There are two fuses for the low-voltage power supplies located on the printed circuit board. If one or more of the green LEDs on the PCB does not light, one of these fuses may be blown. If all three LEDs are lit, the low-voltage power supplies are functioning correctly.

To replace the low-voltage fuses:

1. Disconnect the fixture from AC power.
2. Remove the left-side yoke cover (when looking at the head from the back with the text the correct way up as in Figure 16) to access the PCB.

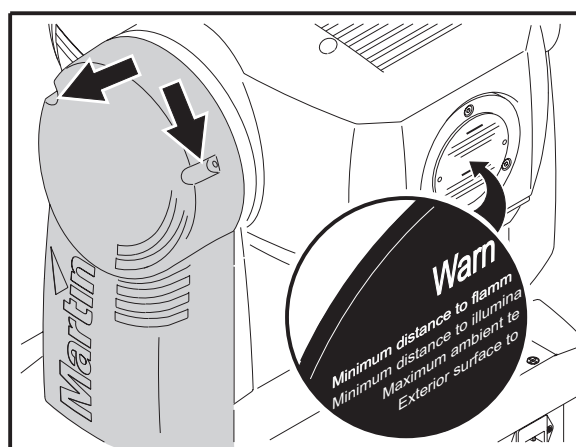

**Figure 16: Identifying and removing the left-hand yoke cover**

- Carefully remove and check the two fuses located in the bottom of the PCB (see “*Circuit board connections*” on page 35). Replace as necessary with fuses of the same size and rating (see “*Fuses*” on page 38).
- Re-attach the yoke cover.

If fuses blow repeatedly, have the fixture serviced by a Martin service technician.

## Updating software

The latest MAC 250 Wash firmware is available from the support area of the Martin web site at <http://www.martin.com>. It can be installed via the DMX data link using a supported Martin uploader such as the MP-2, or via a LightJockey 4064 ISA DMX interface.

Note: Intermediate control systems such as the Martin Lighting Director (MLD) and the Martin Matrix must be bypassed when updating fixture software via the DMX link. These systems do not relay the update code correctly because it is not a DMX-compliant signal.

### NORMAL UPDATE

To update fixture software, connect an upload device to the fixture just like a DMX controller and perform a DMX mode upload as described in the uploader’s documentation. There is no need to isolate the MAC 250 Wash from other types of fixtures on the DMX link.

After a software upload, when the MAC 250 Wash boots up it performs a check-sum test of the flash memory and then resets. If the firmware is corrupted, a check-sum error (*CSER*) occurs. A few seconds later the fixture displays *UPL* and is ready for a new DMX-mode upload.

In the unlikely event that a software upload is interrupted, the fixture must be powered off for at least 10 seconds to force the check-sum test. You can repeat the DMX-mode upload as soon as *UPL* is displayed.

### BOOT SECTOR UPDATE

If the normal update procedure fails or the software update notes call for a boot-sector update, install new software as follows:

- Disconnect the fixture from AC power.
- Remove the left-side yoke cover (see Figure 16) to access the PCB.
- See “*Circuit board connections*” on page 35. The boot sector jumper is located next to the plug for the control panel data cable. Move the jumper to the Init setting. Check that the Flash Write jumper is in the Enable position.
- Apply power and perform a boot-mode upload as described in the uploader manual.
- Disconnect the fixture from AC power. Move the jumper back to the Lock setting.
- Re-attach the yoke cover before reapplying power.

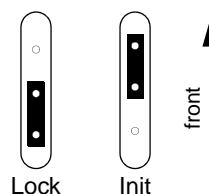

Figure 17: Boot sector jumper

The boot sector update can also be activated in the control panel menu under *UTIL* → *UPL*.

## MAC 250 Beam Upgrade Kit

An update kit is available from Martin that allows the color filters in the MAC 250 Wash to be replaced with beam effect gobos. Full installation instructions are supplied with the kit and can be downloaded free of charge from the MAC 250 Wash Product Support page at [www.martin.com](http://www.martin.com)

Details of controlling the MAC 250 Beam are given at the end of this manual as an appendix.

# DMX protocol

Channel – 16 Bt (16-Bit Mode)	Channel – 16 Ex (16-bit Extended)	Value	Percent	Function
<b>1</b>	<b>1</b>	0 - 19 20 - 49 50 - 72 73 - 79 80 - 99 100 - 119 120 - 127 128 - 147 148 - 167 168 - 187 188 - 190 191 - 193 194 - 196 197 - 199 200 - 202 203 - 207 208 - 217 218 - 227 228 - 237 238 - 247 248 - 255	0 - 7 8 - 19 20 - 28 29 - 31 31 - 39 39 - 47 47 - 50 50 - 58 58 - 65 66 - 73 74 - 75 75 - 76 76 - 77 77 - 78 78 - 79 80 - 81 82 - 85 85 - 89 89 - 93 93 - 97 97 - 100	<b>Shutter, strobe, reset, lamp on/off</b> Shutter closed Shutter open Strobe, fast → slow Shutter open Opening pulse, fast → slow Closing pulse, fast → slow Shutter open Random strobe, fast Random strobe, medium Random strobe, slow Shutter open Random opening pulse, fast Random opening pulse, slow Random closing pulse, fast Random closing pulse, slow Shutter open Reset fixture (see notes a. and b. on left) Shutter open Lamp on Shutter open Lamp off (see note c. on left)
<b>2</b>	<b>2</b>	0 - 255	0 - 100	<b>Dimmer</b> Closed → open
-	<b>3</b>	0 - 255	0 - 100	<b>Dimmer fine (Least Significant Byte)</b>
<b>3</b>	<b>4</b>	0 1 - 127 128 - 254 255	0 1 - 50 51 - 99 100	<b>Cyan</b> White → full cyan  <b>Random CMY color</b> (when set on channel 6 in 16 bt or channel 10 in 16 ex) Normal (full range) Minimum cyan setting (127: full cyan) Maximum cyan setting (128: no cyan) Normal (full range)
-	<b>5</b>	0 - 255	0 - 100	<b>Cyan fine (Least Significant Byte)</b>
<b>4</b>	<b>6</b>	0 1 - 127 128 - 254 255	0 1 - 50 51 - 99 100	<b>Magenta</b> White → full magenta  <b>Random CMY color</b> (when set on channel 6 in 16 bt or channel 10 in 16 ex) Normal (full range) Minimum magenta setting (127: full cyan) Maximum magenta setting (128: no cyan) Normal (full range)
-	<b>7</b>	0 - 255	0 - 100	<b>Magenta fine (Least Significant Byte)</b>
<b>5</b>	<b>8</b>	0 1 - 127 128 - 254 255	0 1 - 50 51 - 99 100	<b>Yellow</b> White → full yellow  <b>Random CMY color</b> (when set on channel 6 in 16 bt or channel 10 in 16 ex) Normal (full range) Minimum yellow setting (127: full cyan) Maximum yellow setting (128: no cyan) Normal (full range)
-	<b>9</b>	0 - 255	0 - 100	<b>Yellow fine (Least Significant Byte)</b>

<b>6</b>	<b>10</b>	0	0	<b>Color wheel scrolling and rotation, random CMY</b> <b>Continuous scrolling (split color positions)</b> White (open) White → CTC 5500-2900 K CTC 5500-2900 K → Pink 312 Pink 312 → UV UV → Red 308 Red 308 → Green 206 Green 206 → Blue 108 Blue 108 → White (open) <b>Stepped scrolling (full color positions)</b> Blue 108 Green 206 Red 308 UV Pink 312 CTC 5500-2900 K White (open)  <b>Continuous rotation</b> Clockwise, fast → slow Counterclockwise, slow → fast  <b>Random CMY color</b> (set min. & max. CMY levels on channels 3, 4 & 5 in 16 bt and channels 4, 6 & 8 in 16 ex. modes) Fast Medium Slow
		1 - 26	0 - 10	
		27 - 51	11 - 20	
		52 - 77	21 - 30	
78 - 102	31 - 40			
103 - 128	41 - 50			
129 - 152	51 - 60			
153 - 179	61 - 70			
180 - 183	71 - 72			
184 - 187	72 - 73			
188 - 191	74 - 75			
192 - 195	75 - 76			
196 - 199	77 - 78			
200 - 203	78 - 79			
204 - 207	80 - 81			
208 - 226	82 - 88			
227 - 245	89 - 96			
246 - 248	97			
249 - 251	98			
252 - 255	99 - 100			
-	<b>11</b>	0 - 255	0 - 100	<b>Color fine (Least Significant Byte)</b>
<b>7</b>	<b>12</b>	0 - 255	0 - 100	<b>Frost filter</b> Open (off) → full
-	<b>13</b>	0 - 255	0 - 100	<b>Frost filter fine (Least Significant Byte)</b>
<b>8</b>	<b>14</b>	0 - 255	0 - 100	<b>Pan</b> Left → right (128 = neutral)
<b>9</b>	<b>15</b>	0 - 255	0 - 100	<b>Pan fine (Least Significant Byte)</b>
<b>10</b>	<b>16</b>	0 - 255	0 - 100	<b>Tilt</b> Up → down (128 = neutral)
<b>11</b>	<b>17</b>	0 - 255	0 - 100	<b>Tilt fine (Least Significant Byte)</b>
<b>12</b>	<b>18</b>	0 - 2	0 - 1	<b>Pan/tilt speed</b> Tracking Fast → slow Tracking, <i>PTSP SLOW</i> (overrides control menu) Tracking, <i>PTSP NORM</i> (overrides control menu) Tracking, <i>PTSP FAST</i> (overrides control menu) Blackout while moving
		3 - 242	1 - 95	
		243 - 245	96	
		246 - 248	97	
249 - 251	98			
252 - 255	99 - 100			
<b>13</b>	<b>19</b>	0 - 2	0 - 1	<b>Effects speed</b> <b>Dimmer, CMY filters</b> Tracking mode Vector speed, fast → slow Tracking, <i>SCUT OFF</i> (overrides control menu) Tracking, <i>SCUT ON</i> (overrides control menu) Vector speed, fast  <b>Color wheel</b> Tracking mode Vector speed, fast → slow Tracking, <i>SCUT OFF</i> (overrides control menu) Tracking, <i>SCUT ON</i> (overrides control menu) Blackout while moving  <b>Frost</b> Tracking mode Vector speed, fast → slow Tracking Vector speed, fast
		3 - 245	1 - 96	
		246 - 248	97	
		249 - 251	98	
		252 - 255	99 - 100	
		0 - 2	0 - 1	
		3 - 245	1 - 96	
		246 - 248	97	
		249 - 251	98	
		252 - 255	99 - 100	
		0 - 2	0 - 1	
		3 - 245	1 - 96	
246 - 251	97 - 98			
252 - 255	99 - 100			

# Control menu

Factory default settings are shown in bold type.

Menu	Item	Options	Notes (default settings in bold print)
ADDR		1-499 (16-bit mode)	DMX address (default address = 1)
		1-493 (16-bit Extended mode)	
PSET		<b>16BT</b>	<b>16-bit</b>
		16EX	16-bit Extended
PATI	SWAP	ON	Map DMX pan control to tilt channel and vice versa.
		OFF	<b>Normal pan and tilt control</b>
	PINV	ON	Reverse DMX pan control, right → left
		OFF	<b>Normal pan control, left → right</b>
	TINV	ON	Reverse DMX tilt control, down → up
		OFF	<b>Normal tilt control, up → down</b>
PTSP		NORM	Normal pan/tilt speed
		FAST	<b>Maximum pan/tilt speed</b>
EFSP		NORM	Medium effects speed
		FAST	Fast effects speed
		PTSS	<b>Pan/tilt speed slave. Effects speed controlled by pan/tilt speed setting.</b>
STUD		OFF	<b>Optimize effects for speed</b>
		ON	Optimize effects for silence (studio mode).
PERS	DISP	ON	<b>Display remains on</b>
		2 MN	Display extinguishes 2 minutes after last key press
		10MN	Display extinguishes 10 minutes after last key press
	DINT	AUTO	<b>Automatic display dimming</b>
		10 - 100	Set display intensity manually
	DLOF	ON	Enable DMX lamp off command
		OFF	<b>Disable DMX lamp off command</b> (but allow DMX lamp off if all 3 CMY channels are set to a value from 230 - 232 / 91%)
	DRES	ON	<b>Enable DMX reset</b>
		OFF	Disable DMX reset (but allow DMX reset if all 3 CMY channels are set to a value from 230 - 232 / 91%)
		5SEC	Allow DMX reset if reset command sent for 5 seconds
	ALON	ON	Lamp strikes automatically within 90 seconds of power on
		OFF	<b>No automatic lamp strike</b>
		DMX	Lamp strikes if DMX is present, douses after 15 mins. if no DMX signal received
	SCUT	ON	<b>Effect wheels turn shortest distance</b>
		OFF	Effect wheels do not cross open position
	DICU	DIM1	Linear dimming curve
		DIM2	<b>Tungsten dimming characteristics</b>
	CMYB	ON	CMY blackout after shutter closed for 3 seconds
OFF		<b>No CMY blackout</b>	

Table 4: Control menu

DFSE	FACT	LOAD	Return all personality settings (not calibrations) to factory defaults
	CUS1	LOAD	Load custom configuration 1
		SAVE	Save custom configuration 1
	CUS2	LOAD	Load custom configuration 2
		SAVE	Save custom configuration 2
	CUS3	LOAD	Load custom configuration 3
SAVE		Save custom configuration 3	
INFO	TIME→HRS	TOTL	Total hours of operation with power on since manufacture
		RSET	Hours of operation since counter reset. To reset, display counter and press [Up] for 5 seconds.
	TIME→L HR	TOTL	Total hours of operation with lamp on since manufacture.
		RSET	Hours of lamp operation since counter reset. To reset, display counter and press [Up] for 5 seconds.
	TIME→L ST	TOTL	Total number of lamp strikes since manufacture.
		RSET	Number of lamp strikes since counter reset. To reset, display counter and press [Up] for 5 seconds.
	TEMP	HEAD	Head temperature
		BASE	Base Temperature
	VERS	X.X.X	CPU firmware version
	DMXL		RATE
		QUAL	Percentage of data received without errors
		STCO	Decimal value of the DMX start code.
		SHUT	Shutter value
		DIM	Dimmer value
		CYAN	Cyan value
		MAG	Magenta value
		YEL	Yellow value
		COL	Color wheel value
		FROS	Frost filter value
		PANC	Coarse pan value
		PANF	Fine pan value
		TILC	Coarse tilt value
		TILF	Fine tilt value
		PTSP	Pan/tilt speed value
	EFSP	Effect speed value	

**Table 4: Control menu**

MAN	RST		Reset fixture	
	L ON		Lamp on	
	LOFF		Lamp off	
	SHUT	OPEN		Open shutter
		CLOS		Close shutter
		STRF		Fast strobe
		STRM		Medium strobe
		STRS		Slow strobe
	DIM	255-0		Dimmer
	CYAN	0-255		Cyan
	MAG	0-255		Magenta
	YEL	0-255		Yellow
	COL	OPEN		Color wheel in open position
		C 1→C6		Color wheel positions 1 → 6
		CW F		Clockwise rotation - fast
		CCWF		Counter-clockwise rotation - fast
		CW M		Clockwise rotation - medium
		CCWM		Counter-clockwise rotation - medium
		CW S		Clockwise rotation - slow
		CCWS		Counter-clockwise rotation - slow
RND F			Random CMY color - fast	
RND M			Random CMY color - medium	
RND S		Random CMY color - slow		
FRO	0-255		Frost filter	
PAN	0-255		Pan left → right	
TILT	0-255		Tilt up → down	
TSEQ	RUN		Run a general test of all effects	
UTIL (Press and hold [Enter] for 3 secs. to access)	FEBA	ON	<b>Enable pan/tilt position correction</b>	
		OFF	Disable pan/tilt position correction	
	EFFB	ON	<b>Enable color wheel position correction</b>	
		OFF	Disable color wheel position correction	
	ADJ		See "Adjustment submenu" on page 32	
	CAL	P DF		Pan offset (1-255)
		T DF		Tilt offset (1-255)
		D DF		Dimmer offset (1-255)
		COOF		Color wheel offset (1-255)
		C DF		Cyan offset (1-255)
		M DF		Magenta offset (1-255)
		Y DF		Yellow offset (1-255)
	DFOF	SURE		Return all offsets to the default settings
	PCBT	SURE		PCB test – for service use only
	FANS	FULL		<b>Fans run at full speed</b>
REG			Fans run at thermostatically regulated speed	
UPLD	SURE		Manually set fixture to software update mode	

Table 4: Control menu

## Adjustment submenu

This menu is accessed in *UTIL*→*ADJ*. Factory default settings are shown in bold type.

Menu	Item	Options	Notes (Default settings in bold print)	
<i>RST</i>			Reset fixture	
<i>L ON</i>			Strike lamp	
<i>L OFF</i>			Douse lamp	
<i>HEAD</i>	<i>TOOL</i>		Send effects to position for mechanical adjustment	
	<i>DIM</i>	<i>ADJ</i>	Send dimmer to position for mechanical adjustment	
		<i>CLOS</i>	Close dimmer	
		<i>OPEN</i>	Open dimmer	
		<i>STR5</i>	Strobe slow	
		<i>STRM</i>	Strobe medium	
		<i>STRF</i>	Strobe fast	
	<i>CYAN</i>	<i>ON S</i>	Position magnet at sensor on cyan effect	
		<i>MIN</i>	Minimum cyan position	
		<i>MAX</i>	Maximum cyan position	
	<i>MAG</i>	<i>ON S</i>	Position magnet at sensor on magenta effect	
		<i>MIN</i>	Minimum magenta position	
		<i>MAX</i>	Maximum magenta position	
	<i>YEL</i>	<i>ON S</i>	Position magnet at sensor on yellow effect	
		<i>MIN</i>	Minimum yellow position	
		<i>MAX</i>	Maximum yellow position	
	<i>COL</i>	<i>ON S</i>	Position magnet at sensor on yellow effect	
		<i>OPEN</i>	Color wheel indexed at open position	
		<i>COL 1 -COL 6</i>	Color wheel indexed at full color positions	
		<i>CW S</i>	Clockwise rotation, slow	
		<i>CW M</i>	Clockwise rotation, medium	
		<i>CW F</i>	Clockwise rotation, fast	
	<i>FRST</i>	<i>ADJ</i>	Send frost effect to position for mechanical adjustment	
		<i>CLOS</i>	Close frost effect (full frost)	
		<i>OPEN</i>	Open frost effect (zero frost)	
		<i>TEST</i>		Mechanical adjustments self test
	<i>PATI</i>		<i>NEUT</i>	Pan and tilt neutral
		<i>PNTD</i>	Pan neutral, tilt down	
		<i>PNTU</i>	Pan neutral, tilt up	
		<i>PLTN</i>	Pan left, tilt neutral	
		<i>PRTN</i>	Pan right, tilt neutral	
		<i>PLTD</i>	Pan left, tilt down	
		<i>PRTU</i>	Pan right, tilt down	

Table 5: Adjustment submenu

## Control panel shortcuts

- To strike the lamp, press [Enter] and [Up].
- To douse the lamp, press [Enter] and [Down].
- To reset the fixture, press [Menu] and [Up].



# Error messages

Display readout	Appears if...	What to do
■■■■■	...there is no communication between the control panel and motherboard (this display appears briefly when switching on the fixture).	<ul style="list-style-type: none"> <li>• Check fuses.</li> <li>• Check cable between control panel and motherboard.</li> <li>• Reinstall software.</li> <li>• Contact service technician.</li> </ul>
MERR	...the EEPROM memory cannot be read.	<ul style="list-style-type: none"> <li>• Contact service technician.</li> </ul>
ⓂPER	...a display programming error occurs due to contaminated upload data.	<ul style="list-style-type: none"> <li>• Repeat upload procedure.</li> <li>• Contact service technician if problem persists.</li> </ul>
ⓂRER	...there is a drive current error.	<ul style="list-style-type: none"> <li>• Contact service technician.</li> </ul>
RCER	...there is a real-time clock error.	<ul style="list-style-type: none"> <li>• Contact service technician.</li> </ul>
COER	...the magnetic-indexing circuit malfunctions (e.g. sensor defective or magnet missing). After a time-out, the color wheel stops in a random position	<ul style="list-style-type: none"> <li>• Contact service technician.</li> </ul>
CYER	...there is a cyan feedback error.	<ul style="list-style-type: none"> <li>• Contact service technician.</li> </ul>
MAER	...there is a magenta feedback error.	<ul style="list-style-type: none"> <li>• Contact service technician.</li> </ul>
YEER	...there is a yellow feedback error.	<ul style="list-style-type: none"> <li>• Contact service technician.</li> </ul>
PAER	...there is a pan error and the sensor cannot find the pan index point. After a time-out, the fixture stops in a random position.	<ul style="list-style-type: none"> <li>• Contact service technician.</li> </ul>
TIER	...there is a tilt error and the sensor cannot find the tilt index point. After a time-out, the fixture stops in a random position.	<ul style="list-style-type: none"> <li>• Contact service technician.</li> </ul>
FBER	...there is a pan/tilt feedback error.	<ul style="list-style-type: none"> <li>• Contact service technician.</li> </ul>
FBER	...there is a pan feedback error.	<ul style="list-style-type: none"> <li>• Contact service technician.</li> </ul>
FRET	...there is a tilt feedback error.	<ul style="list-style-type: none"> <li>• Contact service technician.</li> </ul>
HOT	...the lamp is too hot to restrike.	<ul style="list-style-type: none"> <li>• Allow lamp to cool (typically for about 8 minutes).</li> </ul>
LERR	...the lamp cannot be struck.	<ul style="list-style-type: none"> <li>• Replace lamp.</li> </ul>
LIER	...a light sensor error occurs.	<ul style="list-style-type: none"> <li>• Contact service technician.</li> </ul>
HTCO	...the head temperature cutoff is activated.	<ul style="list-style-type: none"> <li>• Allow fixture to cool.</li> <li>• Clean fans, air filter and air vents.</li> <li>• Contact service technician if problem persists.</li> </ul>
SHER	...there is a short-circuit and the lamp strikes without a command.	<ul style="list-style-type: none"> <li>• Contact service technician.</li> </ul>
HTER	...the head temperature sensor malfunctions.	<ul style="list-style-type: none"> <li>• Contact service technician.</li> </ul>
BTER	...the base unit temperature sensor malfunctions.	<ul style="list-style-type: none"> <li>• Contact service technician.</li> </ul>
NIE	...a CPU error occurs (NIE = non-maskable interrupt error).	<ul style="list-style-type: none"> <li>• Reset fixture</li> <li>• Upload new software</li> <li>• Contact service technician</li> </ul>

**Table 6: Error messages**

# Troubleshooting

Problem	Probable cause(s)	Remedy
One or more of the fixtures is completely dead.	No power to fixture.	<ul style="list-style-type: none"> <li>Check that power is switched on and cables are plugged in.</li> </ul>
	Primary fuse blown.	<ul style="list-style-type: none"> <li>Replace fuse.</li> </ul>
	Secondary fuse(s) blown (located on PCB inside base).	<ul style="list-style-type: none"> <li>Check fuses on PCB and replace.</li> </ul>
Fixtures reset correctly but all respond erratically or not at all to the controller.	The controller is not connected.	<ul style="list-style-type: none"> <li>Check connections.</li> </ul>
	XLR pin-out of the controller does not match pin-out of the first fixture on the link (i.e. signal is reversed).	<ul style="list-style-type: none"> <li>Install a phase-reversing cable between the controller and the first fixture on the link.</li> </ul>
Fixtures reset correctly but some respond erratically or not at all to the controller.	Poor data quality	<ul style="list-style-type: none"> <li>Check data quality (page 14). If much under 100 percent, the problem may be a bad data link connection, poor quality or broken cabling, missing termination, or a defective fixture disturbing the link.</li> </ul>
	Bad data link connection	<ul style="list-style-type: none"> <li>Inspect connections and cables. Correct poor connections. Repair or replace damaged cables.</li> </ul>
	Data link not terminated with 120 ohm termination plug.	<ul style="list-style-type: none"> <li>Insert termination plug in output jack of the last fixture on the link.</li> </ul>
	Incorrect addressing of the fixtures.	<ul style="list-style-type: none"> <li>Check address setting.</li> </ul>
	One of the fixtures is defective and disturbs data transmission on the link.	<ul style="list-style-type: none"> <li>Bypass one fixture at a time (unplug both connectors and connect them directly together) until normal operation is regained. Have the defective fixture serviced by a qualified technician.</li> </ul>
	XLR pin-out on fixtures does not match (pins 2 and 3 reversed).	<ul style="list-style-type: none"> <li>Install a phase-reversing cable between the fixtures or swap pins 2 and 3 in the fixture that behaves erratically.</li> </ul>
No light and <i>LEPP</i> error message displayed.	The power supply settings do not match local AC voltage and frequency.	<ul style="list-style-type: none"> <li>Disconnect fixture. Check settings (“AC power” on page 8) and correct if necessary.</li> </ul>
	Lamp missing or blown	<ul style="list-style-type: none"> <li>Disconnect fixture and replace lamp.</li> </ul>
Lamp cuts out intermittently.	Fixture is too hot.	<ul style="list-style-type: none"> <li>Allow fixture to cool.</li> <li>Clean fans, air filter and air vents.</li> <li>Ensure that ambient temperature (Ta) does not exceed 40° C (104° F).</li> </ul>
	The power supply settings do not match local AC voltage and frequency.	<ul style="list-style-type: none"> <li>Disconnect fixture. Check settings (“AC power” on page 8) and correct if necessary.</li> </ul>

**Table 7: Troubleshooting**

# Circuit board connections

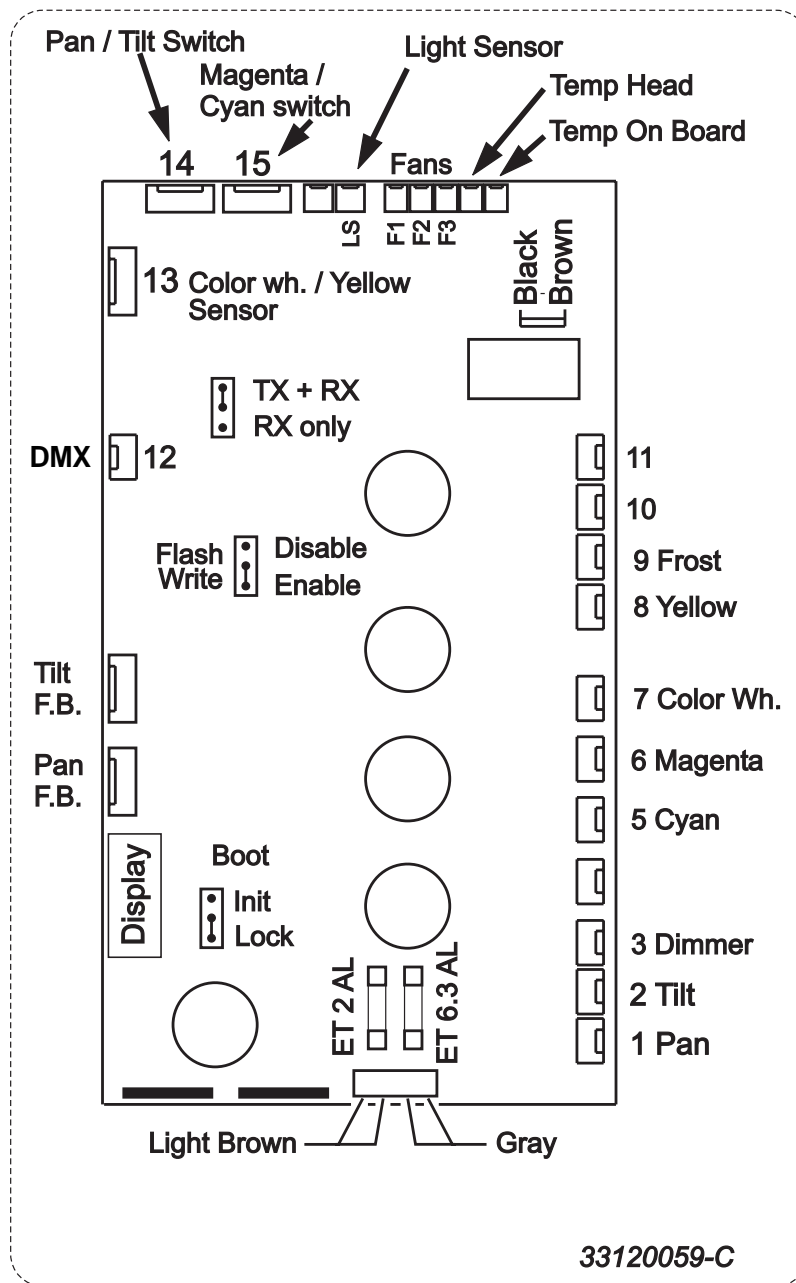

# MAC 250 Wash™ Specifications

## PHYSICAL

Base length	375 mm (14.8 in.)
Base width	315 mm (12.4 in.)
Yoke width	393 mm (15.5 in.)
Height	538 mm (21.2 in.)
Weight	22.9 kg (50.4 lbs)

## SOURCE

Lamp	250 W discharge
Base	GY 9.5
Approved models:	
Philips MSD 250/2 (installed as standard)	3000 hr, 8500 K, 250 W
Osram HSD 250/78	3000 hr, 7800 K, 250 W
GE CSD 250/2	3000 hr, 9000 K, 250 W

## DYNAMIC EFFECTS

Color mixing	CMY, independently variable 0 - 100%
Color wheel	6 interchangeable filters (incl. UV transmitter and CTC) + open, indexing, continuous rotation
Mechanical dimmer	0 - 100%
Shutter	Strobe effect up to 14 Hz, pulse effects, instant open and blackout
Diffuser	Variable frost filter
Pan	540°
Tilt	257°

## CONTROL AND PROGRAMMING

DMX channels	13/19
Setting and addressing	Control panel with LED display
16-bit control	CMY, color wheel, dimmer, frost, pan and tilt
Movement control options	Tracking and vector
Protocol	USITT DMX512/1990
Receiver	Opto-isolated RS-485
Firmware update	Serial upload via DMX link

## PHOTOMETRICS

### MAC 250 Wash standard

Total output	7700 lumens
One-tenth peak output	6800 lumens
Half-peak output	3100 lumens
Cutoff angle	25.9°
One-tenth peak angle	19.1°
Half-peak angle	9.1°
Measurement conditions	226 V, 50 Hz; no effects applied
Measurement source	Philips MSD 250/2

### MAC 250 Wash standard with frost

Total output	.4800 lumens
One-tenth peak output	.4100 lumens
Half-peak output	.1900 lumens
Cutoff angle	.48.8°
One-tenth peak angle	.34.8°
Half-peak angle	.16.0°
Measurement conditions	226 V, 50 Hz; with frost applied
Measurement source	Philips MSD 250/2

### MAC 250 Wash wide-angle lens

Total output	.9100 lumens
One-tenth peak output	.8600 lumens
Half-peak output	.4900 lumens
Cutoff angle	.61.5°
One-tenth peak angle	.52.5°
Half-peak angle	.28.7°
Measurement conditions	.232 V, 50 Hz; no effects applied
Measurement source	Philips MSD 250/2

### MAC 250 Wash wide-angle lens with frost

Total output	.5100 lumens
One-tenth peak output	.4700 lumens
Half-peak output	.2600 lumens
Cutoff angle	.77.9°
One-tenth peak angle	.65.6°
Half-peak angle	.34.7°
Measurement conditions	232 V, 50 Hz; with frost applied
Measurement source	Philips MSD 250/2

## CONNECTIONS

AC Power input	3-pin IEC
Data input	locking 3-pin and 5-pin XLR male sockets
Data output	locking 3-pin and 5-pin XLR female sockets
Data pinout	pin 1 shield, pin 2 cold (-), pin 3 hot (+)

## THERMAL

Maximum ambient temperature ( $T_a$ )	40° C (104° F)
Maximum surface temperature	160° C (320° F)

## AC POWER

Operating range	100 - 250 V, 50/60 Hz
AC input	3-prong IEC male socket

### Typical power and current

100 V, 50 Hz	319 W, 3.8 A, PF 0.83
100 V, 60 Hz	317 W, 3.4 A, PF 0.93
120 V, 50 Hz	320 W, 2.9 A, PF 0.91
120 V, 60 Hz	314 W, 2.7 A, PF 0.96
208 V, 50 Hz	320 W, 1.9 A, PF 0.81
208 V, 60 Hz	319 W, 1.7 A, PF 0.92
230 V, 50 Hz	323 W, 1.6 A, PF 0.89
230 V, 60 Hz	326 W, 1.5 A, PF 0.95
250 V, 50 Hz	326 W, 1.5 A, PF 0.89
250 V, 60 Hz	325 W, 1.4 A, PF 0.96

*V = volts, Hz = hertz, W = watts, A = amps, PF = power factor*

*Allow for a deviation of +/- 10% from typical figures listed above.*

*Measurements made at nominal voltage.*

## Fuses

Main fuse	6.3 A / 250 V, time-delay	– P/N 05020020
Fuse F1	6.3 A / 250 V, time-delay	– P/N 05020020
Fuse F2	2.0 A / 250 V, time-delay	– P/N 05020009

## ELECTROMECHANICAL EFFECTS

Cyan filter	.0 - 100%
Magenta filter	.0 - 100%
Yellow filter	.0 - 100%
Color wheel	6 colors plus open and split positions
Dimmer	.0 - 100%
Shutter	Variable from 0 - 14 flashes per second
Zoom diffuser	.0° - 16°
Pan	.540° in 0.013° steps
Tilt	.257° in 0.007° steps

## APPROVALS



EU EMC	EN 55 103-1, EN 55 015, EN 61 547
EU safety	EN 60598-2-17
US safety	ANSI/UL 1573
Canadian safety	CSA C22.2 No. 166

## CONSTRUCTION

Housing	UV-resistant fiber-reinforced composite
Ingress protection factor	IP 20

## INSTALLATION

Orientation	any
Minimum distance to combustible materials	0.1 m (4 in.)
Minimum distance to illuminated surfaces	0.5 m (20 in.)
Minimum center-to-center distance between MAC 250 Wash fixtures	410 mm (16.2 in.)

## INCLUDED ITEMS

Philips MSD 250/2 lamp (installed)	P/N 97010114
Safety wire	P/N 62400327
2 x T-shaped clamp attachment brackets MAC 250/300, with 1/4-turn fasteners	P/N 91602008
Mains cable, 3 m (9.8 ft), IEC 3-pin	P/N 11501013
Wide-angle lens	P/N 41600026
User manual	P/N 35000164

## ACCESSORIES

MAC 250 Beam Kit	P/N 91610101
DMX termination plug, 3-pin male XLR	P/N 91613017
Half-coupler clamp	P/N 91602005
G-clamp	P/N 91602003
Quick trigger clamp	P/N 91602007
Safety wire, universal, 50 kg safe work load	P/N 91604003
Double flightcase (empty) for MAC 250 Krypton/Entour/Wash	P/N 91510014

## RELATED ITEMS

Martin DABS1™ USB-XLR interface device and cables	P/N 91611144
Martin Universal USB-DMX Interface Box™	P/N 90702045

**ORDERING INFORMATION**

MAC 250 Wash™, white (in cardboard box) . . . . .	P/N 90225810
MAC 250 Wash™ (in cardboard box) . . . . .	P/N 90225840
MAC 250 Wash™ (in double flightcase) . . . . .	P/N 90225841

*Specifications subject to change without notice. For the latest product specifications, see [www.martin.com](http://www.martin.com)*





# Appendix: MAC 250 Beam

If the standard MAC 250 Wash is converted to a MAC 250 Beam with a MAC 250 Beam Kit (available from Martin, P/N 91610101), i.e. color filters are removed and beam effect gobos are inserted in the color wheel, the wheel looks as shown in Figure 18:

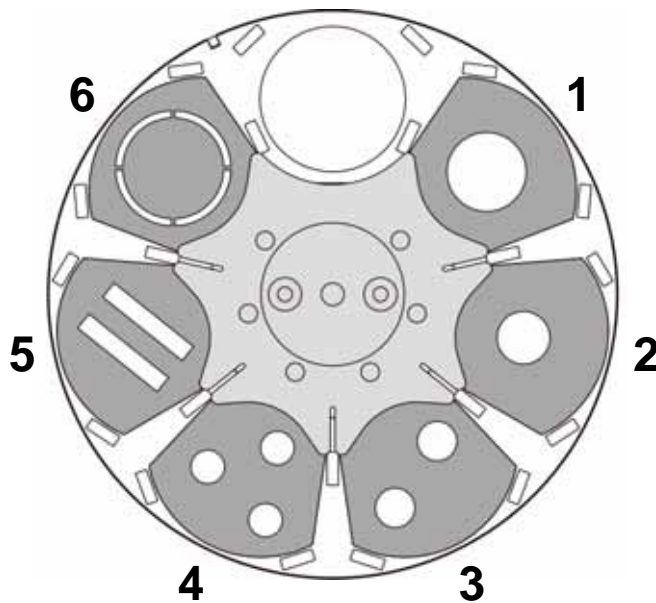

Position	Gobo
1	Beam aperture 15
2	Beam aperture 10
3	Beam two dots
4	Beam three dots
5	Beam two bars 10
6	Beam cone 15

Table 8: Standard MAC 250 Beam gobos

Figure 18: MAC 250 Beam updated color wheel (viewed from lamp side)

The control menu commands *HEAD* → *COL* → *COL 1* - *COL 6* now manually select beam effect gobos rather than color filters. DMX Channel 6 (in 16-bit mode) or 10 (in 16-bit extended mode) now controls beam effect gobos as shown in Table 9:

<b>6</b>	<b>10</b>	0	0	<b>Beam gobo wheel scrolling and rotation, random CMY</b> <b>Continuous scrolling (split gobos)</b> Open Open → Beam aperture 15 Beam aperture 15 → Beam aperture 10 Beam aperture 10 → Beam two dots Beam two dots → Beam three dots Beam three dots → Beam two bars Beam two bars → Beam cone Beam cone → Open  <b>Stepped scrolling (full gobos)</b> Beam cone Beam two bars Beam three dots Beam two dots Beam aperture 10 Beam aperture 15 Open  <b>Continuous rotation</b> Clockwise, fast → slow Counterclockwise, slow → fast  <b>Random CMY color</b> (set min. & max. CMY levels on channels 3, 4 & 5 in 16-bit and channels 4, 6 & 8 in 16-bit ex. modes) Fast Medium Slow
		1 - 26	0 - 10	
		27 - 51	11 - 20	
		52 - 77	21 - 30	
		78 - 102	31 - 40	
103 - 128	41 - 50			
129 - 152	51 - 60			
153 - 179	61 - 70			
180 - 183	71 - 72			
184 - 187	72 - 73			
188 - 191	74 - 75			
192 - 195	75 - 76			
196 - 199	77 - 78			
200 - 203	78 - 79			
204 - 207	80 - 81			
208 - 226	82 - 88			
227 - 245	89 - 96			
246 - 248	97			
249 - 251	98			
252 - 255	99 - 100			

Table 9: MAC 250 Beam updated DMX channel 6/10







---

[www.martin.com](http://www.martin.com) • Olof Palmes Allé 18 • 8200 Aarhus N • Denmark  
Tel: +45 8740 0000 • Fax +45 8740 0010