

MECHANICAL SPECIFICATIONS

FIXTURE

Dimensions:

mm: 595 x 598 x 911
in: 23.4 x 23.6 x 35.9

PACKED IN ROADCASE

Dimensions

mm: 699 x 724 x 1080
in: 27.5 x 28.5 x 42.5

Weight: 53.5 kg (118 lb) **Weight:** 107.5 kg (237 lb)

Mounting Information: The DL.2 fixture can be truss mounted using 1/4 camlock c-clamps brackets. It can also stand upright on a stable surface.

Colors Available: Black:

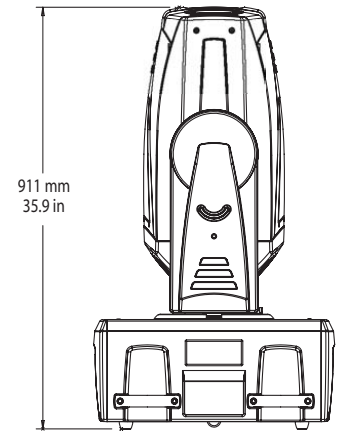
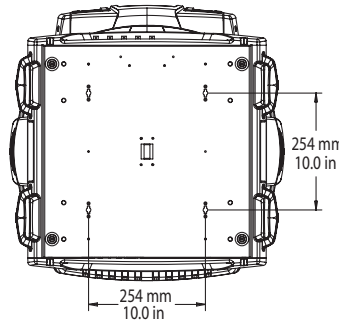

ELECTRICAL/LAMP* SPECIFICATIONS

Input ratings: 100–120V 7.0A maximum 50/60Hz,
200–240V 3.5A 50/60Hz

Power factor: 0.94

Fuse: Power supply output fuse: 5A, 250V slow blow only.

Lamp: 300 W UHP (300W NSH)

Light Output: 5500 ANSI lumens (5000 ANSI lumens)

Rated Lamp Life: 1500 hours

Throw ratio: 1.8 - 2.4:1

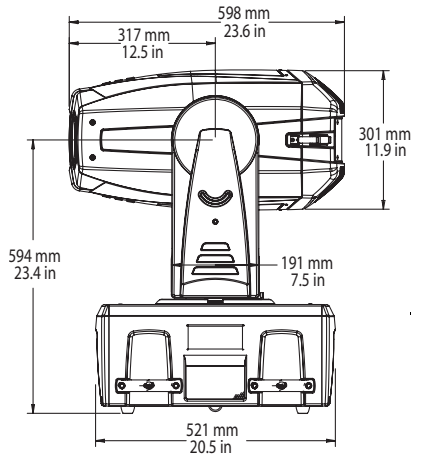
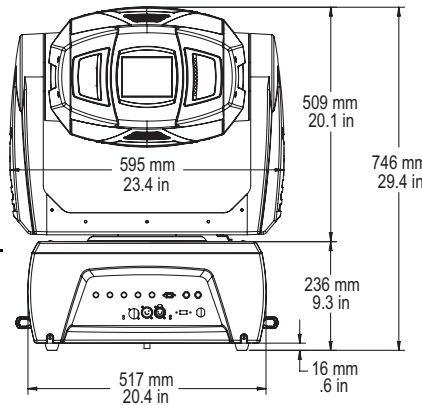

COMPUTER

Processor: Intel Core2 Duo 2.4 GHz

Memory: 2 GB DDR2 RAM

Hard drive: Seagate SATA

Video Card: ATI X1900XT

Operating System: Windows XP embedded

PROJECTOR*

Model: Christie Digital LX 55/(LX50)

Aspect ratio: 4:3 native

Brightness uniformity: 90%

Contrast ratio: 1000:1 (1200:1), full on/full off

Display technology: 1.3" LCD w/MLA, 3 panels

Panel resolution: 1024 x 768 dots

Zoom Lens Throw Ratio: 1.8 - 2.4:1

* Data in parentheses for units manufactured prior to 9/1/06

CAMERA SYSTEM

Construction: Super HAD CCD sensor technology

Lens: 18x Optical Zoom

Horizontal view angle: 48° – 2.8°

Auto focus Range: 29mm – 800mm

Camera Capture Resolution: 768 x 494 pixels

Picture Elements: 380K pixels {768 (H) x 582 (V)}

Minimum working distance: 29mm (TELE end, 800mm (WIDE end)

OPERATION

Pan: 400° **Tilt:** 240°

Control Options: DMX512, Art-Net

Minimum Focus Distance: 1.4 meters (4.6 ft)

Compliances: CE, CSA, ETL

Video Connectors: RGBHV—BNC x 5, VGA—DB15, S-Video—mini-DIN

Peripheral/Network Connectors: 2 USB ports, Ethernet

DMX Connectors: 5-pin male and female XLR connectors

Scanning Frequency: H-sync. = 15 – 100 KHz, V-sync. = 50 – 100 Hz

Horizontal Resolution: 800 TV lines (HDTV):

Environmental Tolerances:

Ambient Operating Temperature Range: 5°–35°C (40°–95° F)

Humidity: 20%–80% (non-condensing)

Altitude: 0–8850ft (0–2700m)

Software Upgrades: Download Operating software and CMA software from the High End Systems web site (www.highend.com)

DMX Channels (Version 2.0)

Motion Parameters	DMX Chan	Global Parameters	DMX Chan	Graphic Object Parameters	DMX Chan			
					Obj1	Obj2	Obj3	Obj4
Motion Functions		Global Intensity	22	Opacity	77	122	167	212
Pan	1	Global Effect 1	23	3-D Object File	78	123	168	213
	2	Global Effect 1 Modifier 1	24	Media Folder	79	124	169	214
Tilt	3	Global Effect 1 Modifier 2	25	Media file	80	125	170	215
	4	Global Effect 1 Modifier 3	26	In frame	81	126	171	216
Dimmer	5	Global Effect 2	27		82	127	172	217
Focus	6	Global Effect 2 Modifier 1	28	Out frame	83	128	173	218
Zoom	7	Global Effect 2 Modifier 2	29		84	129	174	219
Mspeed	8	Global Effect 2 Modifier 3	30	Play mode	85	130	175	220
Macro	9	Global Effect 3	31	Play speed	86	131	176	221
Control	10	Global Effect 3 Modifier 1	32	Sync Mode	87	132	177	222
		Global Effect 3 Modifier 2	33	Sync To	88	133	178	223
Camera Functions		Global Effect 3 Modifier 3	34	Visual mode	89	134	179	224
Zoom	11	Global Effect 4	35	Visual Mode Modifier 1	90	135	180	225
	12	Global Effect 4 Modifier 1	36	Visual Mode Modifier 2	91	136	181	226
Focus	13	Global Effect 4 Modifier 2	37	Graphic Effect 1	92	137	182	227
	14	Global Effect 4 Modifier 3	38	Effect 1 Modifier 1	93	138	183	228
Infrared	15	Global Effect 5	39	Effect 1 Modifier 2	94	139	184	229
Camera Shutter	16	Global Effect 5 Modifier 1	40	Effect 1 Modifier 3	95	140	185	230
White Balance	17	Global Effect 5 Modifier 2	41	Graphic Effect 2	96	141	186	231
Camera Orientation	18	Global Effect 5 Modifier 3	42	Effect 2 Modifier 1	97	142	187	232
Camera Effects	19	Mask Select (default iris)	43	Effect 2 Modifier 2	98	143	188	233
Red Gain	20	Mask Size	44	Effect 2 Modifier 3	99	144	189	234
Red Gain	21	Mask Edge	45	Graphic Effect 3	100	145	190	235
		Edge Fade Top	46	Effect 3 Modifier 1	101	146	191	236
		Edge Fade Right	47	Effect 3 Modifier 2	102	147	192	237
		Edge Fade Bottom	48	Effect 3 Modifier 3	103	148	193	238
		Edge Fade Left	49	X-axis rotation	104	149	194	239
		Keystone Top Left X	50		105	150	195	240
		Keystone Top Left Y	51	Y-axis rotation	106	151	196	241
		Keystone Top Right X	52		107	152	197	242
		Keystone Top Right Y	53	Z-axis rotation	108	153	198	243
		Keystone Bottom Right X	54		109	154	199	244
		Keystone Bottom Right Y	55	Scale X	110	155	200	245
		Keystone Bottom Left X	56		111	156	201	246
		Keystone Bottom Left Y	57	Scale Y	112	157	202	247
		Keystone X Ratio	58		113	158	203	248
		Keystone Y Ratio	59	Scale Z	114	159	204	249
		Framing Top Left X	60		115	160	205	250
		Framing Top Left Y	61	X Position	116	161	206	251
		Framing Top Right X	61		117	162	207	252
		Framing Top Right Y	63	Y Position	118	163	208	253
		Framing Bottom Right X	64		119	164	209	254
		Framing Bottom Right Y	65	Z Position	120	165	210	255
		Framing Bottom Left X	66		121	166	211	256
		Framing Bottom Left Y	67					
		Viewpoint mode	68					
		Viewpoint Position X	69	PART NUMBERS				
			70	Fixture				
		Viewpoint Position Y	71	67010001: DL2 fixture, Black				
			72	Accessories				
		Viewpoint Position Z	73	55030070: LX50 Replacement Lamp				
			74	55030082: LX55 Replacement Lamp				
		Global Control	75	80260014: Replacement Filter				
		Global Control Modifier	76					