

coemar

ProSpot 575 L

**instruction
manual**

1st edition, february 2002

Index

1. Packaging	Pag. 3
2. Transportation	„ 3
3. Important safety information	„ 4
4. Lamp: installation and replacement	„ 5
5. Operating frequency and voltage	„ 7
6. Installation	„ 8
7. Mains connection	„ 9
8. Signal connection	„ 10
9. Powering up	„ 11
10. DMX addressing	„ 12
11. Display panel functions	„ 13
11.1 Turning on the ProSpot 575 LX without articulated movement	„ 14
11.2. Resetting the counter	„ 14
11.3. test	„ 14
12. DMX 512 signal functions	„ 15
12.1 Iris diaphragm function	„ 17
13. Aligning the lamp in the optical system	„ 18
14. Opening up the projector housing	„ 19
15. Interchanging gobos	„ 20
16. Operating voltage and frequency alteration (Reserved for technical staff)	„ 22
16.1. Selecting the operating voltage on the autotransformer	„ 22
16.2. Selecting the operating frequency on the power supply of the ProSpot 575 LX	„ 23
17. Automatic internal functions	„ 24
18. Maintenance	„ 25
19. Electronic motor alignment	„ 26
20. Spare parts	„ 27

Congratulations on having purchased a **coemar** product. You have assured yourself of a fixture of the highest quality, both in componentry and in the technology used. We renew our invitation to you to complete the service information on the previous page, to expedite any request for service information or spares (in case of problems encountered either during, or subsequent to, installation). This information will assist in providing prompt and accurate advice from your **coemar** service centre.

1. Packaging

Following the instructions and procedures outlined in this manual will ensure the maximum efficiency of this product for years to come.

Open the packaging and ensure that no part of the equipment has suffered damage in transit. In case of damage to the equipment, contact your carrier immediately by telephone or fax, following this with formal notification in writing.

packing list

Ensure the packaging contains:

- 1 **ProSpot 575 LX**
- 1 **instruction manual**

2. Transportation

The **ProSpot 575 LX** should be transported in its original packaging or in a **coemar** approved flight case.

In order to manufacture a suitable flight case, we recommend the following simple procedure to be followed, which will stop the articulated movement of the **ProSpot 575 LX** during transportation.

The following diagram illustrates **coemar's** recommended construction of the internal for a roadcase to suit this fixture.

A) Padding around the entire projector, including the base, with suitable padding materials.

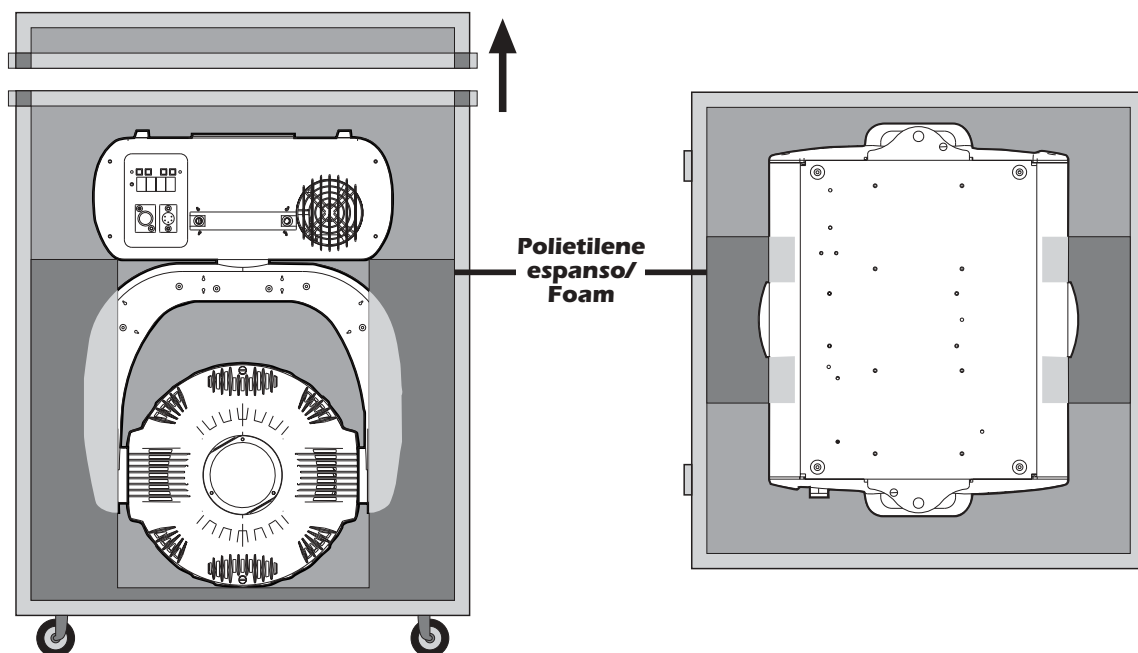

3. Important safety information

Fire prevention:

- 1. ProSpot 575 LX** utilises a Philips 575 MSD or 575 MSR/2; the use of any alternative lamp is not recommended and will null and void the fixture's warranty.
- Never locate the fixture on any flammable surface.
- Minimum distance from flammable materials: 0,5 m.
- Minimum distance from the closest illuminable surface: 2 m.
- Replace any blown or damaged fuses only with those of identical values. Refer to the schematic diagram if there is any doubt.
- Connect the projector to mains power via a thermal magnetic circuit breaker.

prevention of electric shock:

- High voltage is present in the internals of the unit. Isolate the projector from mains supply prior to performing any function which involves touching the internals of the unit, including lamp replacement.
- For mains connection, adhere strictly to the guidelines outlined in section 7 of this manual.
- The level of technology inherent in the **ProSpot 575 LX** requires the use of specialised personnel for all service applications; refer all work to your authorised **coemar** service centre.
- A good earth connection is essential for proper functioning of the projector. Never operate the unit without proper earth connection.
- The fixture should never be located in an exposed position, or in areas of extreme humidity. A steady supply of circulating air is essential.

Protection against ultraviolet radiation:

- Never turn on the lamp if any of the lenses, filters, or the carbon fibre housing is damaged; their respective functions will only operate efficiently if they are in perfect working order.
- Never look directly into the lamp when it is operating.

Safety:

- The projector should always be installed with bolts, clamps, and other fixings which are suitably rated to support the weight of the unit.
- Always use a secondary safety chain of a suitable rating to sustain the weight of the unit in case of the failure of the primary fixing point.
- The external surface of the unit, at various points, may exceed 150°C. Never handle the unit until at least 10 minutes have elapsed since the lamp was turned off.
- Always replace the lamp if any physical damage is evident.
- Never install the fixture in an enclosed area lacking sufficient air flow; the ambient temperature should not exceed 35°C.
- A hot lamp may explode. always wait for at least 10 minutes to elapse after the unit has been turned off prior to attempting to replace the lamp.
Always wear suitable hand protection when handling the lamp.

Protection against penetration by external agents

- The fixture is classified ordinary apparatus ; its protection grade against penetration by external agents, solid or liquid, is IP 20

4. Lamp: Installation and replacement

ProSpot 575 LX utilises a Philips 575 MSD or a Philips 575 MSR/2 lamp at 575 watts with a GX 9,5 lampbase. The lamp is available from your authorised **coemar** sales agent.

Philips 575 MSD

coemar cod.	105215
wattage	575 w
luminous flux	43.000 lm
colour temperature	6000° K
base	GX 9,5
rated life	3000 hours

Philips 575 MSR/2

coemar cod.	105245/2
wattage	575 w
luminous flux	49.000 lm
colour temperature	7.200° K
base	GX 9,5
rated life	1000 hours

Attention

Turn off the power prior to opening up the unit.

The fixture's internal temperature can reach 250° C after 5 minutes, with a maximum peak of 350° C; ensure that the lamp is cold prior to attempting removal. The fixture should be allowed to stand and cool for 10 minutes prior to its removal. MSR/SA lamps are part of the mercury vapour family of discharge lamps and must be handled with great care. The lamp operates at high pressure, and the slight risk of explosion of the lamp exists if operated over its recommended life. We recommend, therefore, that the lamp be replaced within the manufacturer's specified lamp life.

mounting the lamps

1) Using a Phillips head screwdriver, remove the screws (**A**) which hold the lampholder in place, located at the rear of the projector head.

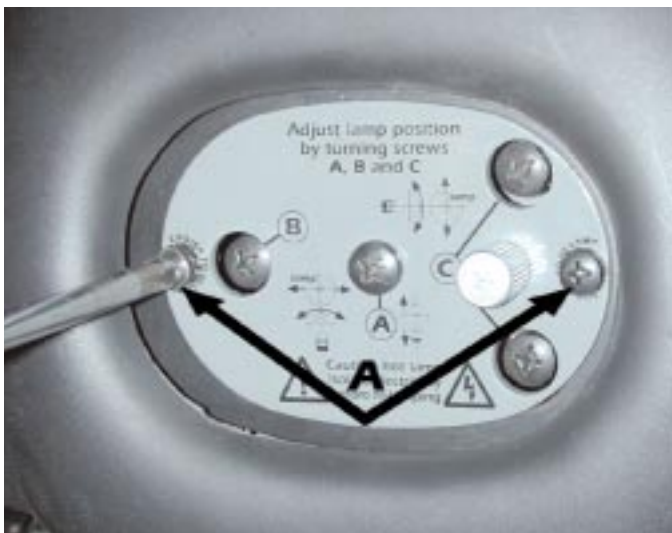

2) Remove the lampholder assembly (**B**).

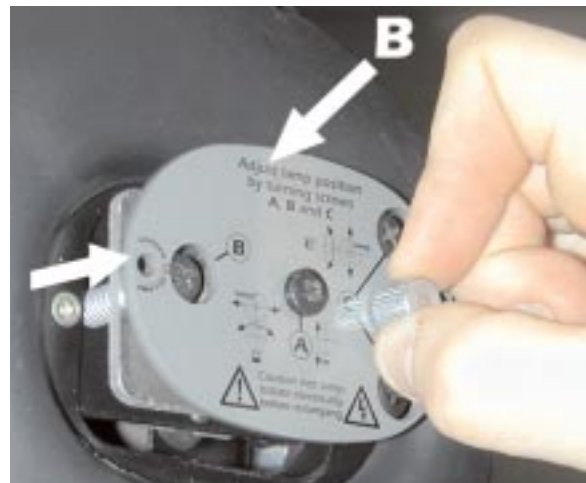

3) Locate the lampholder (**C**)

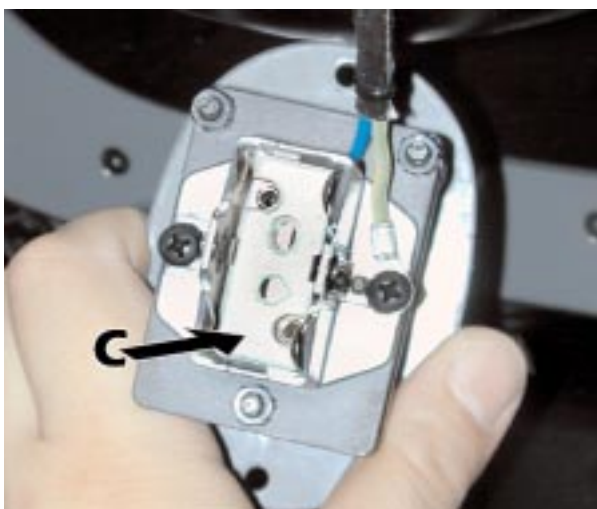

English

4) Insert the lamp.

The lamp used is manufactured from quartz glass and should be handled with care; always adhere to the instructions supplied in the lamp's packaging. Never touch the glass directly, use the tissue provided in the lamp's packaging. The GX 9,5 lampbase is symmetrical in construction. DO NOT USE UNDUE FORCE. In case of difficulty, re-read the instructions and repeat the procedure.



5) Replace the lamp assembly and replace and tighten the screws (A) which were previously removed.



Attention: we recommend that the lamp be realigned in the optical train of the unit to avoid overheating of the dichroic filters and other internal components of the unit. refer to section **13** for instructions about this procedure.

5. Operating voltage and frequency

The projector may operate at voltages including 115-208, 230 or 240V .at 50 or 60 Hz; **coemar** presets (barring specific requests) a voltage of 230v at a frequency of 50Hz.. The preset voltage is indicated on a sticker located on the base of the projector, as shown in the diagram.

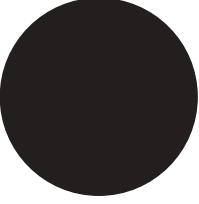
factory set main at:	
	
<input type="checkbox"/> 100V	<input type="checkbox"/> 115V
<input type="checkbox"/> 208V	<input checked="" type="checkbox"/> 230V
<input type="checkbox"/> 240V	
<input checked="" type="checkbox"/> 50Hz	<input type="checkbox"/> 60Hz

If the operating voltage and frequency selected on the projector do not match those in use in the country in which you are operating, follow the instructions located in section **17. Altering the operating voltage and frequency.**
Incorrect voltage and frequency selection will detrimentally affect the operation of the projector.

6. Installation

mounting

ProSpot 575 LX may be either floor or ceiling mounted.

For floor mounting installations, the **ProSpot 575 LX** is provided with four rubber mounting feet.

For ceiling mounted installations we suggest the use of appropriate clamps or fixings to attach the fixture to the mounting surface.

The structure from which the unit is hung should be of sufficient rating to hold the weight of the unit, as should any clamps used to hang the unit. The structure should also be sufficiently rigid so as not to move or shake whilst the **ProSpot 575 LX** moves during its operation.

2 mounting holes of $\text{Ø}13\text{ mm}$ (**A**) are located on the base of the **ProSpot 575 LX** allowing for the connection of G-clamps.

safety chain

We recommend the use of two safety chains (cod. 069) - connected to the **ProSpot 575 LX** and to the suspension truss in order to avoid the fixture accidentally falling. If using an after-market safety chain not manufactured by **coemar**, ensure that it is of sufficient rating to hold the weight of the unit.

You may attach the safety chain to the holes (**B**) located on the base of the fixture, as shown in the diagram below.

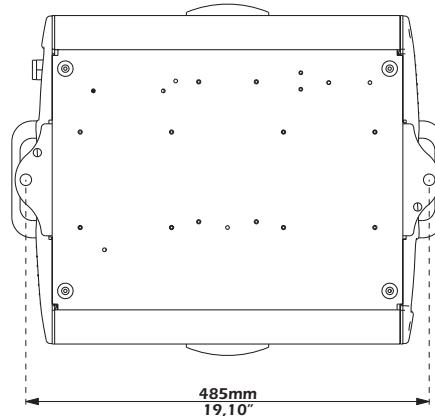

protection against liquids

The projector contains electric and electronic components which should under no circumstances come into contact with oil, water, or any other liquid. The proper workings of the unit will be compromised should this occur.

movement

The projector has a maximum movement of 385° in the base and 260° in the yoke; **DO NOT** place any obstructions in the path of the projector's movement.

risk of fire

Each fixture produces heat and must be installed in a well-ventilated position. The minimum recommended distance from flammable material is: 0.5m. Minimum distance from the object being illuminated is: 2 m.

forced ventilation

You will note on inspection that the fixture features various air inlets and cooling fans, located on both the base and head of the fixture. these should, under no circumstances, be blocked or obstructed whilst the projector is in operation. Doing so could cause the fixture to seriously overheat thereby compromising its proper operation.

ambient temperature

The projector should never be installed in locations lacking a constant flow of air. The ambient temperature should not exceed 35°C .

7. Mains connection

cabling

The mains cable provided is thermally resistant, complying to the most recent international standards. It meets or exceeds VDE and IEC norms, IEC 331, IEC 332 3C, CEI 20 35.

NB: In case of cable replacement, similar cable with comparable thermal resistant qualities must be used exclusively (cable 3x1.5 \varnothing external 10 mm, rated 300/500V, tested to 2KV, operating temperature $-40^{\circ} +180^{\circ}$, **coemar** cod. CV5309).

mains connection

ProSpot 575 LX can operate at voltages from 208V-230V-240V at 50 or 60Hz (operating voltage and frequency can be selected as described in section 5 of this manual).

Prior to connecting the unit to your mains supply, ensure that the model in your possession correctly matches the mains supply available to you. For connection purposes, ensure your plug is of a suitable rating of 8 amps at 230V and 11 amps at 115V.

Locate the mains cable which exits the base of the unit and connect as shown below:

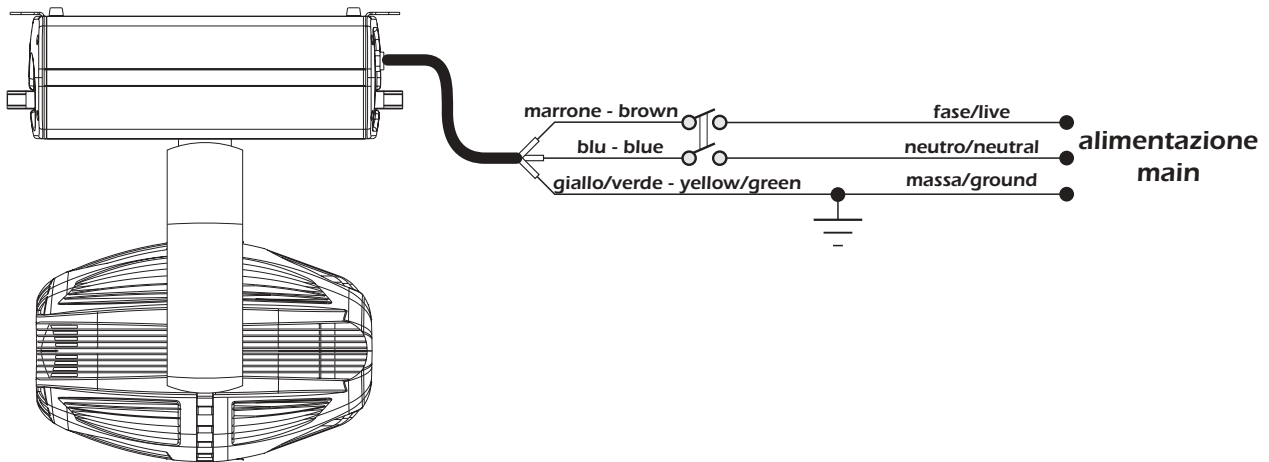

protection

The use of a thermal magnetic circuit breaker is recommended for each **ProSpot 575 LX**.

A good earth connection is essential for the correct operation of the fixture. Strict adherence to regulatory norms is strongly recommended.

8. Signal connection

Control signal is digital, and is transmitted via two pair screened $\varnothing 0.5\text{mm}$ cable.
Connection is serial, utilising XLR 3 male and female sockets located on the base of the **ProSpot 575 LX**, labeled **DMX 512 In** and **OUT** (see diagram).

Pin connections conform to the international standard:

pin 1= screening 0 volt

pin 2= data -

pin 3= data +

If using a controller which output signal via an XLR 5 (5 pin) socket, do not use pins 4 and 5, leaving them unconnected.

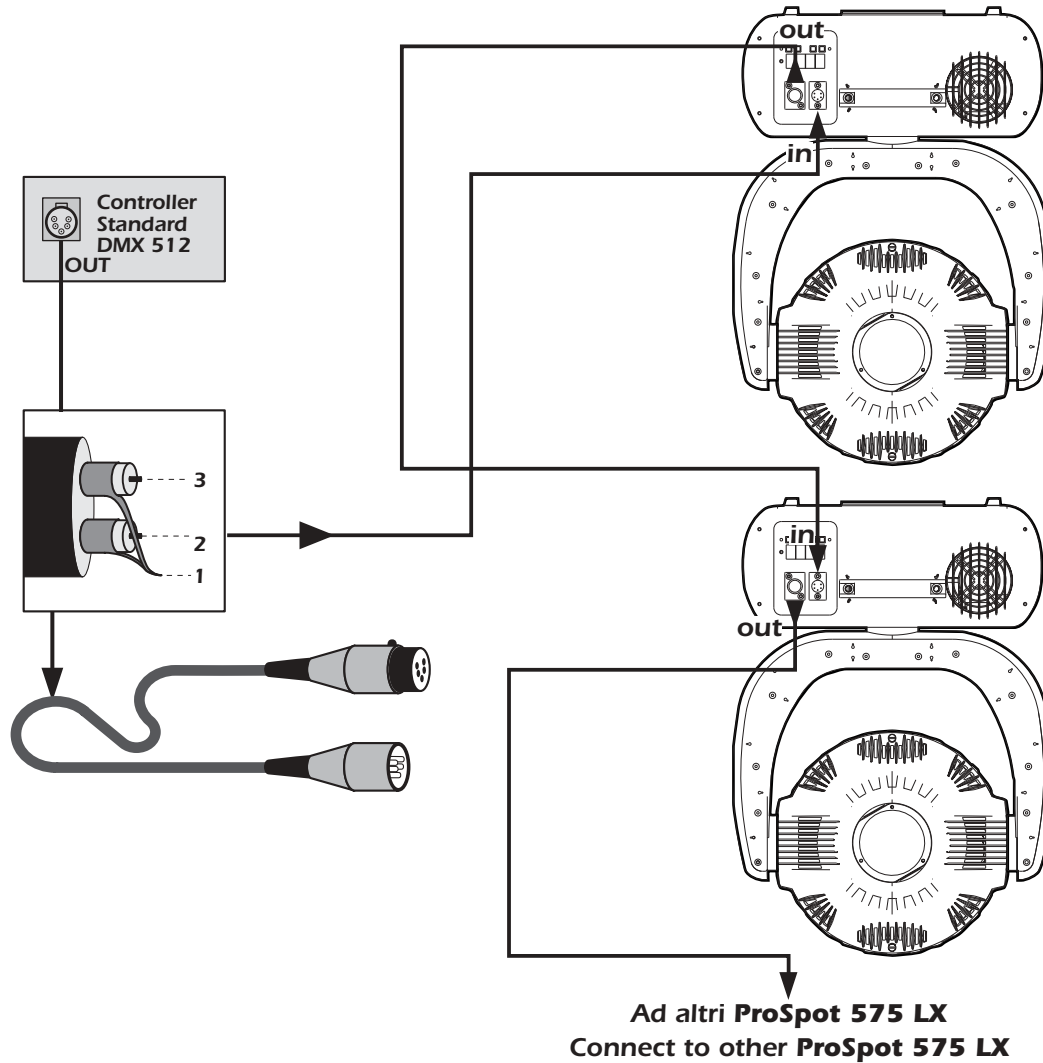

Ensure that all data conductors are isolated from one another and the metal housing of the connector.

Note: the housing of the cannon XLR 3 or 5 must be isolated.

9. Powering up

After having followed the preceding steps, turn on the DMX 512 controller which will be used to control the **ProSpot 575 LX**. Following this, turn on the power to the projector, and turn on the projector's power switch. The projector will perform a reset function on all the internal and external motors. This will last some few seconds, after which it will be subject to the external signal from the controller.

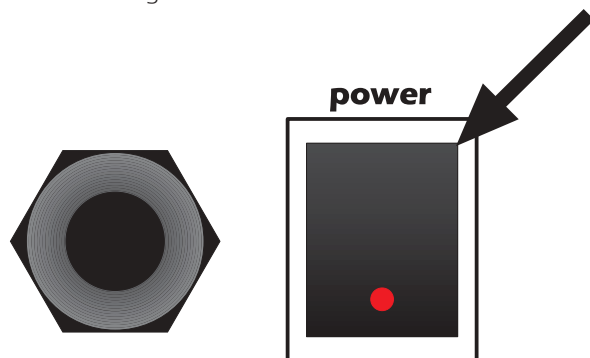

DMX led

The DMX led will be static on to indicate that **DMX 512** signal is being correctly received by the projector.

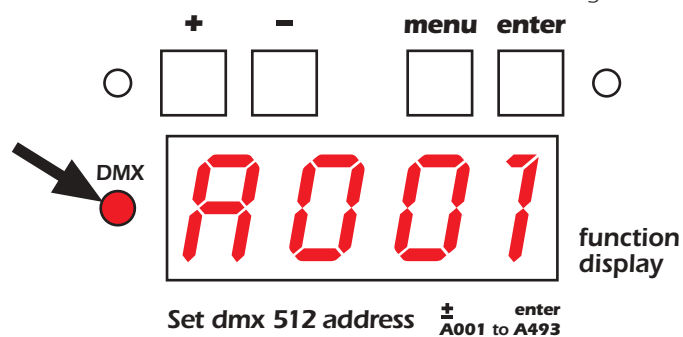

If the led is off, the projector is not receiving signal. check the cabling and the functioning of the controller.

10. DMX addressing

Each **ProSpot 575 LX** utilises **16** channels of **DMX 512** for complete control. (for more details see paragraph **12. DMX 512 signal functions**)

DMX coding

To ensure that each projector accesses the correct signal, it is necessary to correctly address each fixture. Any number between 1 and 497 can be generated via the multifunction panel of the **ProSpot 575 LX**.

This procedure must be carried out on every **ProSpot 575 LX** being used.

When powered up initially, each projector will show **A001** which indicates **DMX address 1**; a projector thus addressed will respond to commands on channel **1** to **16** from **DMX 512 controller**. A second unit should be addresses as **17**, a third as **33** and so on until the final **ProSpot 575 LX**, has been addressed.

altering dmx addresses

- 1) Press the **+** or **-** button until the display shows the **DMX** required, the characters in the display panel will flash to indicate that the selection is not stored in memory.

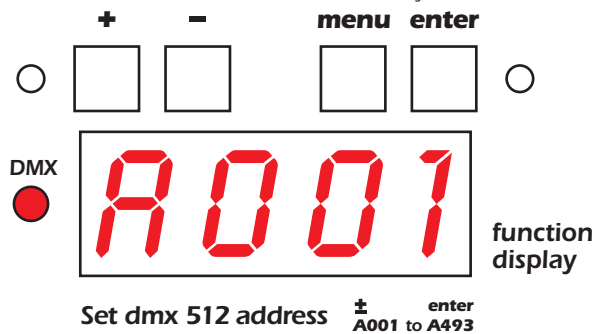

- 2) Press the **enter** button to confirm your selection; the display panel will cease to flash and the projector will now respond to the new **DMX 512** address.
- 3) To better understand the function of each channel, we refer you to section 12 "**Control channel functions from a DMX 512 controller**".











































































Important Note: Keeping the **+** or **-** button pressed will cause the display to alter at increased speed, allowing a faster selection to be effected.

By pressing the **-** button, you may inadvertently select a DMX address which is not being communicated to the fixture by the controller, for example 500. If this is the case, the display will slow the data reception, (since it does not exist), and you will note that it is slow to respond to your commands (for example altering an address or requesting or confirming a reset). You may solve this problem by either sending data to this address, or by altering the incorrect DMX setting of the **ProSpot 575 LX** in question.

11. Display panel functions

The display panel of ProSpot 575 LX shows all the functions available; it is possible to change some of those parameters and to add some functions. Changing the setting made by coemar can vary the functions of the device so that it will not respond to the DMX 512 controller used to control it. Carefully follow the instructions before applying any variations or selections.

NOTE: the symbol  shows which key has to be pushed to obtain the function desired.

 AD01 menu	 +o-	D IRP pan movement inversion	 enter	 +o-	CW clockwise	 enter
		To reverse horizontal movement direction of the beam from left to right and vice versa on DMX level variation.		 +o-	CCW counterclockwise	 enter
 +o-		DIRT tilt movement inversion	 enter	 +o-	CW clockwise	 enter
		To revert vertical movement direction of the beam from the bottom upwards and vice versa on DMX level variation		 +o-	CCW counterclockwise	 enter
 +o-		MOVE type of movement PAN e TILT	 enter	 +o-	STRD standard movement	 enter
		To choose between fast and soft Pan and Tilt movement.		 +o-	SOFT soft movement	 enter
 +o-		IRIS iris control	 enter	 +o-	PUL pulse	 enter
		To select the iris diaphragm's control mode, by choosing between the regular mode and the regular plus pulse mode.		 +o-	LIN regular	 enter
 +o-		OPTO optic sensor deactivation	 enter	 +o-	ON sensors activation	 enter
		To deactivate optic sensors that sense the position of the eyoke and the base of the unit and that allow the return in position of the unit if accidentally knocked out of place.		 +o-	OFF sensors deactivation	 enter
 +o-		LAMP lamp control	 enter	 +o-	STRD ignition by DMX 512	 enter
		Lamp on/off control inhibition by DMX signal		 +o-	ON lamp permanently on	 enter
 +o-		FAN fans control	 enter	 +o-	STRD automatic on/off	 enter
		Fans function controlled through PCB (strd). Fans always on (on)		 +o-	ON fans always on	 enter
 +o-		DISP reverse display	 enter	 +o-	AA suspended position	 enter
		Reverses display's reading verse depending on the mounting position. (on the ground or suspended)		 +o-	BB reversed	 enter
 +o-		LED display control	 enter	 +o-	OFF switching off display	 enter
		To disable display visualization.			( any key to reactivate it)	
 +o-		TEST motors test	 enter	 +o-	PAN pan movement test	 enter
		Device operation test without using DMX signal		 +o-	ALL motors test	 enter
 +o-		RESE reset	 enter		--- reset activation	 enter
		Reset function				
 +o-		DEMO demo program	 enter		--- demo program activation	
		To demonstrate the fixture's operativity				
 +o-		RATE DMX speed	 enter		24.50 numeric value	
		DMX signal reception speed.				
 +o-		TEMP internal temperature	 enter		100 numeric value in C°	
		reading of the lamphouse's internal temperature				
 +o-		HOUR working time (lamp on)	 enter		0280 numeric value in hours	
		visualization of unit's working time (lamp on) (reset not possible)				
 +o-		LIFE lamp life	 enter		0550 numeric value in hours	
		visualization of lamp life (time covered by mains supply from last reset operation)				
 +o-		HTOT total working time	 enter		0600 numeric value in hours	
		total visualization of unit's working time (time covered by mains supply) (reset not possible)				

English

11.1. Powering up the ProSpot 575 LX without articulated movement

This function may be useful should you need to power up the **ProSpot 575 LX** to re-address it or alter any parameters and you wish to do this in the absence of any articulated movement.

- 1) Turn on the projector whilst holding down both the **enter** button and the **-** button.

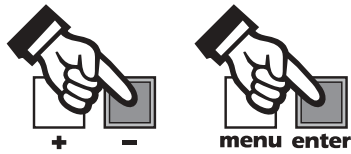

The projector will proceed with a reset of all the motors with the exception of those which control articulated movement, the pan and tilt motors, which remain static.

- 2) You may alter the DMX address, or any other parameters available via the menu system without any articulated movement.
- 3) To return to normal functioning the projector needs simply be turned off and then turned on once again via the power button.

11.2. Counter reset

The lamp life counter needs to be reset to zero at every lamp change to provide accurate information on lamp life

- 1) Turn off the projector
- 2) Power up the **ProSpot 575 LX** whilst simultaneously holding down the **+** and **-** buttons.

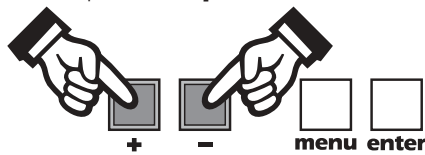

- 3) Press the **menu** button.
- 4) Press the **+** or **-** button until the display shows **LIFE** (for lamp life).
- 5) Press the **enter** button to confirm your selection; the display will show **0000** confirming that the counter has been reset.

11.3. test

This function allows for a test sequence to be carried out on the respective motors of the unit in the absence of any DMX signal.

- 1) Press the **menu** button.
- 2) Press the **+** or **-** button until the display shows **TEST** (for test).
- 3) Press the **enter** button to confirm your selection; the display will show **PAN** (for pan movement test). Press the **+** or **-** buttons for subsequent tests from **PAN** to **ALL**.

PAN= pan axis movement

TILT= tilt axis movement

DIMM= dimmer movement

SHUT= shutter and strobe

IRIS= iris diaphragm movement

FOCU= focus

GOB1= gobo 1 selection (wheel nearest the lamp)

GR1= gobo 1 fine rotation and positioning

GOB2= gobo 2 selection

PRIS= prism

COL1= color wheel 1 (closest to the lamp)

ALL= all motors reset

In these tests the projector simulates the reception of a DMX 512 signal which is increasing from 1 to 255 on the selected channel.

- 4) Press the **enter** button to confirm your selection of test to be carried out.

12. DMX 512 signal functions

If all the instructions described to this point have been followed, the 16 channels of your DMX 512 controller will allow full control of the functions of the **ProSpot 575 LX** as described in the table below:

channel	function	type of control	effect	decimal
1	Base (pan) coarse	proportional	coarse control of the base movement	0-255
2	Base (pan) fine	proportional	fine control of the base movement	0-255
3	Yoke (tilt) coarse	proportional	coarse control of the Yoke movement	0-255
4	Yoke (tilt) fine	proportional	fine control of the Yoke movement	0-255
5	dimmer	step	closed	0-7
		proportional	from close to open	8-255
6	Shutter, Strobe	step	Shutter closed	0-9
		proportional	Synchro strobe-effect from slow to fast (max. 10 flashes/second)	10-66
		step	Shutter open	67-68
		proportional	Pulse-effect in sequences, close slow, open fast (adjustment from slow to fast)	69-125
		step	Shutter open	126-127
		proportional	Pulse-effect in sequences, close fast, open slow (adjustment from fast to slow)	128-184
		step	Shutter open	185-187
		proportional	Random strobe-effect from slow to fast	188-244
		step	Shutter open	245-255
7	iris	step	open	0-9
		proportional	from large to small	10-124
		step	iris small	125-129
		proportional	iris pulse, with increasing pulse speed	130-189
		step	open	190-192
		proportional	iris pulse, with increasing pulse speed plus flash effect	193-251
		step	open	252-255
8	focus	proportional	proportional focus control	0-255
9	rotating gobo, selection	step	Open	0-10
		step or proportional depending on ch	gobo 1	11-40
		step or proportional depending on ch	gobo 2	41-70
		step or proportional depending on ch	gobo 3	71-100
		step or proportional depending on ch	gobo 4	101-130
		step or proportional depending on ch	gobo 5	131-160
		step or proportional depending on ch	gobo 6	161-192
		proportional	Gobo wheel rotation from slow to fast	193-255
10	rotating gobo 360° indexing	step	no effect	0-10
		proportional	proportional indexable gobo positioning 360°	11-255
11	gobo rotation & fine indexing	proportional	proportional indexable fine gobo positioning 360°	0-100
		proportional	continuous gobo rotation clockwise with proportional speed from max to min.	101-176
		step	gobo stop	177-179
		proportional	continuous gobo rotation counter-clockwise with proportional speed from min. to max	180-255
12	static gobo selection	step	Open	0-10
		step or proportional depending on ch	gobo 1	11-40
		step or proportional depending on ch	gobo 2	41-70
		step or proportional depending on ch	gobo 3	71-100
		step or proportional depending on ch	gobo 4	101-130
		step or proportional depending on ch	gobo 5	131-160
		step or proportional depending on ch	gobo 6	161-192
		proportional	Gobo wheel rotation from slow to fast	193-255

English

channel	function	type of control	effect	decimal
13	prism selection & rotation	step	no prism	0-10
		step	prism	11-20
		proportional	continuous prism rotation clockwise with proportional speed from fast to slow	21-136
		step	prism stop	137-139
		proportional	continuous prism rotation counterclockwise with proportional speed from slow to fast	140-255
14	color wheel	step	Open/white	0-7
		step or proportional depending on ch	color 1	8-27
		step or proportional depending on ch	color 2	28-47
		step or proportional depending on ch	color 3	48-67
		step or proportional depending on ch	color 4	68-87
		step or proportional depending on ch	color 5	88-107
		step or proportional depending on ch	color 6	108-127
		proportional	Forwards rainbow effect from fast to slow	128-190
		step	No rotation	191-192
		proportional	Backwards rainbow effect from slow to fast	193-255
15	gobo and color positioning mode Act on channels 9,12,14	step	Steps between gobos from level 11 to 192/ Steps between color from level 6 to 127	0-10
		step	From no gobo to gobo 6, 360° gobo positioning became proportional (level 11/192)	11-125
		step	From no color to color 6, 360° color positioning became proportional (level 6/127)	126-239
		step	Gobo and color positioning became proportional	240-255
16	Lamp ON, motor Reset, pan/tilt speed control mode	step	lamp off	0-10
		step	park, no function	11-29
		step	pan/tilt reset (only once)	30-65
		step	all motor reset except dimmer, pan, tilt (only once)	66-100
		step	all motor reset except dimmer (only once)	101-135
		step	all motor reset (only once)	136-170
		step	inhibit auto lens on iris	171-249
		step	lamp on (pan/tilt standard movement)	250-255
Back panel can modify function channel (inhibit lamp off)				
note 1: function channel (16) has a delay time of 6 seconds to prevent accidental activation.				
note 2 :on/off lamp mode is not affected unless an opposite value is received				

12.1 Iris diaphragm functions

Via the **IRIS** function, it is possible to select the iris diaphragm's mode of control.



To select the iris diaphragm's control mode, by choosing between the regular mode and the regular plus pulse mode.

The possible options are:

LIN = linear; control over the iris is proportional, from maximum to minimum opening (0-255).

channel	function	type of control	effect	decimal
7	iris	proportional	from large to small	0-255

PUL = linear + pulse; channel number 7 will operate as per the following dmx chart:

channel	function	type of control	effect	decimal
	iris	step	open	0-9
		proportional	from large to small	10-124
		step	iris small	125-129
		proportional	iris pulse, with increasing pulse speed	130-189
		step	open	190-192
		proportional	iris pulse, with increasing pulse speed plus flash effect	193-251
		step	open	252-255

13. Aligning the lamp in the optical system

Aligning the lamp in the optical system is achieved via the 3 adjusters at the rear of the projector. This procedure should be undertaken to properly align the lamp in the optical system and to avoid the possible overheating of the internal components due to the incorrect focusing of the beam onto components not intended to be exposed to this.

alignment procedure

Alignment is effected via the 3 adjusters **A**, **B** and **C** operating in conjunction with each other. The lamp should be on, black-out and dimmer fully open, and no colour filters inserted.

If the lamp is not correctly aligned, a hot-spot will be noticeable. This is a function of the lamp's positioning. Use the two adjusters **B** and **C** to bring the hot-spot to the centre of the beam. Use the third adjuster (**A**) to flatten the beam to maximum uniformity.

vertical adjustment

Screw **(C)** acts on a lever and spring assembly to position the lamp via a horizontal movement within the reflector; rotate it until correct positioning is achieved.

horizontal adjustment

Screw **(B)** acts on a lever and spring assembly to position the lamp via a horizontal movement within the reflector; rotate it until correct positioning is achieved.

axial adjustment

Screw **(A)** moves the entire lamp assembly axially within the unit; rotate it until correct positioning is achieved, resulting in a flat, even beam.

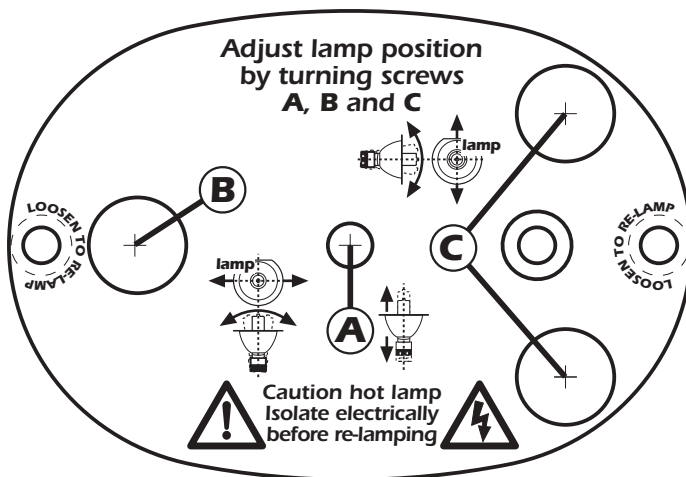

14. Opening up the projector housing

By removing the casing, complete access is available to the internals of the projector.

Attention

Remove mains power prior to accessing the internal components of the projector.

- 1) Loosen the screws which affix the upper and lower covers.



- 2) Once unscrewed, simply lift the covers to access the internal components of the fixture.



15. Interchanging gobos

ProSpot 575 LX utilises a mechanical system which allows the fixture's gobos to be removed without the need for specialised equipment.

Replacement gobos should be made of either heat resistant glass or metal.

An ever-increasing range of gobos is available from your **coemar** sales network.

replacing gobos

Gobo dimensions are as follows:

rotating gobo wheel

∅ external = 32,9 mm

∅ of image with defined edge = 28 mm

∅ of image with undefined edge = 30 mm

thickness = from 0,2 to 3,5 mm

fixed gobo wheel

∅ external = 32,9 mm

∅ of image = 26 mm

thickness = from 0,2 to 3,5 mm

replacing gobos on the rotating gobo wheel

When replacing gobos as shown in the following diagrams, ensure that the projector is NOT powered up.

1- Open the projector housing as described in the section above, **Opening up the projector housing**

2- Loosen the screw as shown in the diagrams and move the metal leaf to allow easier access to the gobos

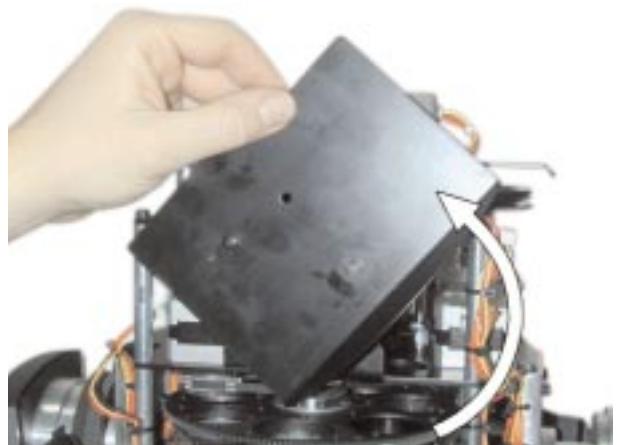

3) Release the gobo retaining spring and thereby carefully remove the gobo

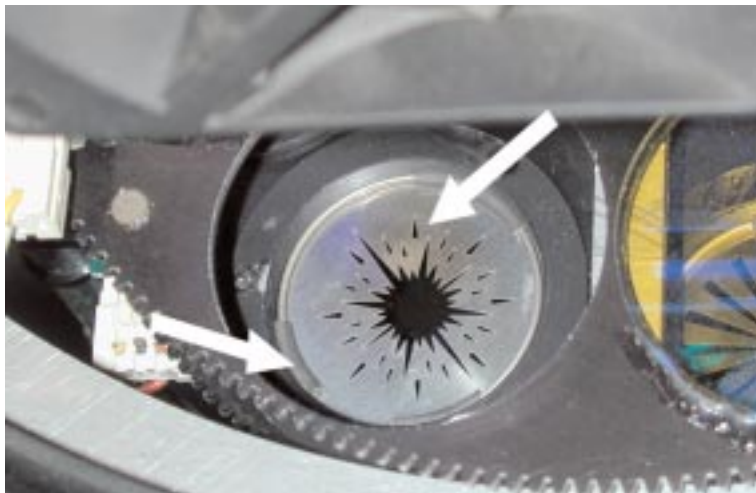

4) Reverse the procedure to install a replacement gobo.

Replacing gobos on the fixed gobo wheel

To replace fixed gobos, proceed as per the previous instructions; we remind you that power should NOT be on.

1- Open the projector housing as described in the section above, **Opening up the projector housing**

2- Locate the fixed gobo wheel

3) Release the gobo retaining spring and thereby carefully remove the gobo

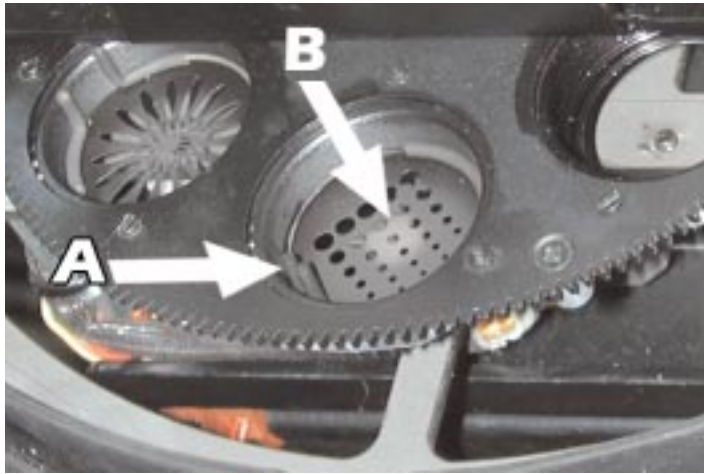

4) Reverse the procedure to install a replacement gobo.

English

16. Altering the operating voltage and frequency (Reserved for technical staff only)

If the factory preset operating voltage and frequency do not correspond to those in use in your country of operation, you may alter the settings as described in the following paragraphs.

Incorrect selection of operating voltage and frequency will seriously compromise the functioning of the projector and immediately void the warranty.

16.1. Selecting the voltage on the autotransformer

- 1) Loosen the screws on the cover of the base of the unit, as shown in the diagram below, using a Philips head screwdriver, thereby removing the cover completely and allowing access to the internal components of the base of the **ProSpot 575 LX**.



- 2) Locate the autotransformer in the base of the unit.

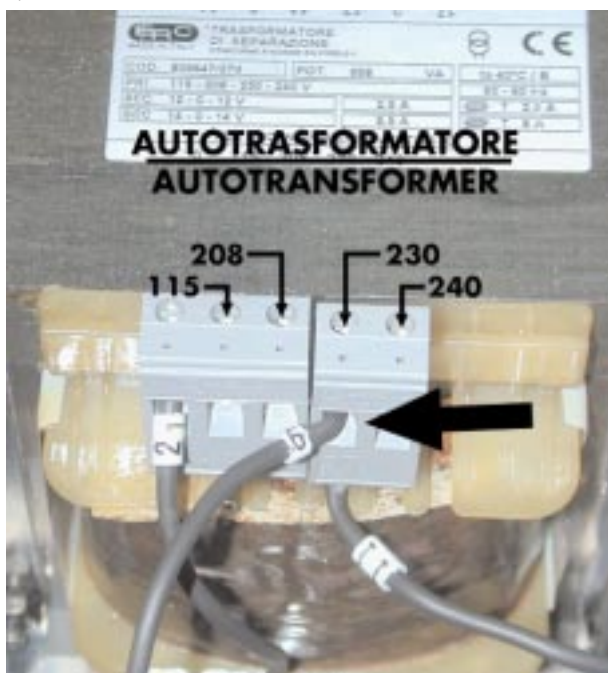

- 3) Select a voltage from amongst 100, 115, 208, 230 and 240V by removing cable n° 6 and moving it to the required voltage. To determine which is the correct tap, refer to the sticker located on the autotransformer. Cables number 11 and 21 should not be moved under any circumstances.
- 4) If the operating voltage selected is 115V replace the 8 Amp T fuse (which is suitable for 208/230/245 V operation) with one rated at 15 Amps T. The fuseholder is located in the base of the unit. The operation should be reversed should the voltages be reversed. Replacement fuses of suitable ratings were provided in the packaging of your fixture with this manual.



T8A @230V
T15A @115V

- 5) Operating frequency may now be set (if necessary) or the base cover replaced with the four screws previously removed.
- 6) Note on the sticker on the outside of the ProSpot 575 LX the new voltage which you have selected, as shown in figure 1.

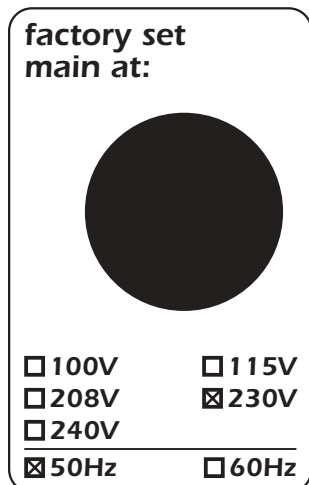
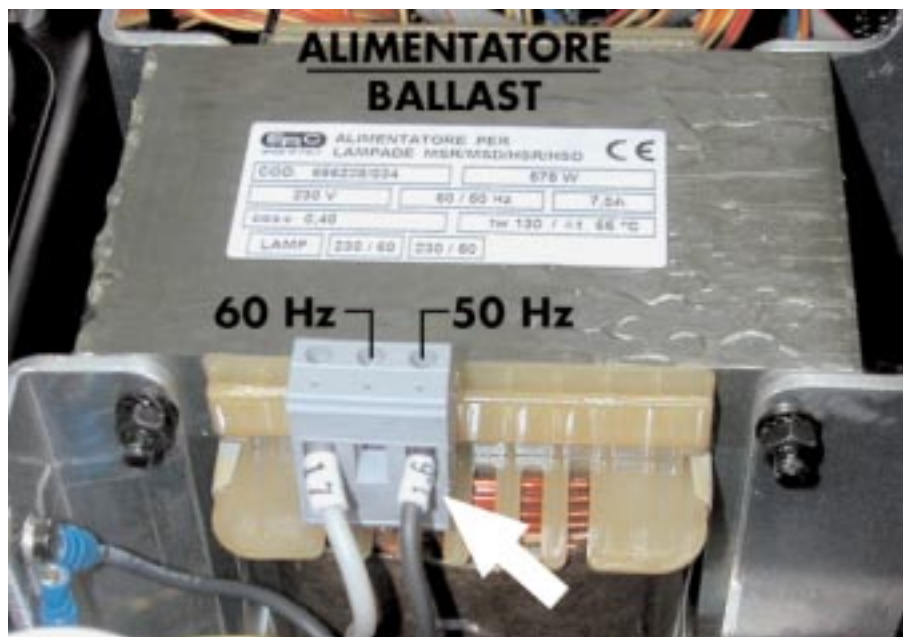

Figure 1

16.2. Selecting the frequency on the power supply of the ProSpot 575 LX

- 1) Locate the power supply on the left of the base.
- 2) Select from either 50 or 60Hz by moving cable n° 16 to the required position. To ensure you have selected the correct tap, refer to the sticker located on the power supply.



- 1) Locate the power supply on the left of the base.
- 2) Select from either 50 or 60Hz by moving cable n° 16 to the required position. To ensure you have selected the correct tap, refer to the sticker located on the power supply.
- 3) Replace the base cover and fasten using the screws previously removed.
- 4) Note on the sticker on the outside of the ProSpot 575 LX the new frequency which you have selected, as shown in figure 1 below.

17. Automatic internal functions

ProSpot 575 LX, has several automatic functions and features which at first glance may not be noticed. However, they serve to add functionality to the projector, and to assist in extending the serviceability of the unit.

on-board hot-strike timer

This on-board feature ensures that the operator cannot attempt to strike the lamp for more than 20 seconds consecutively. If the lamp does not strike, the timer will attempt to reignite the lamp for 20 seconds each minute for 8 consecutive minutes. If the lamp has still not ignited, the circuitry will presume the lamp has reached the end of its operating life and will stop voltage to the lamp circuit.

The display will show **LAER** (error in lamp circuitry).

This is designed to protect the ballast and lamp ignitor from prolonged usage in less than ideal conditions.

NOTE: it is important to replace a lamp that is at the end of its useful life and replace it. Old lamps are generally progressively more difficult to strike.

thermal protection

A thermal sensor in the body of the **ProSpot 575 LX** protects the unit against overheating.

The thermal sensor operates by removing voltage to the lamp if the ambient temperature rises above a preset maximum due to either less than ideal air circulation around the fixture or in the event of cooling fan failure.

automatic realignment

An internal 4 point encoder system allows the **ProSpot 575 LX** to return to its correct position in case the unit is accidentally knocked out of alignment whilst operating. This is particularly useful if the projector is to be mounted on the floor in a position where the performer or artist may accidentally bump the unit.

NOTE: this facility may be deactivated if desired (see section 11 display panel functions **OPTO OFF**).

18. Maintenance

Whilst every possible precaution has been taken to ensure the trouble-free operation of your **ProSpot 575 LX**, the following periodic maintenance is highly recommended.

Attention

Disconnect mains power prior to removing the projector housing.

To gain access to the internals of the unit refer to section **14.** of this manual, *Opening the projector housing.*

periodic cleaning lenses and reflectors

Even a fine layer of dust can reduce the luminous output substantially. Regularly clean all lenses and the reflector using a soft cotton cloth, dampened with a specialist lens cleaning solution.

fans and air passages

The fans and air passages must be cleaned approximately every 6 weeks; the period for this periodic cleaning will depend, of course, upon the conditions in which the projector is operating. Suitable instruments for performing this type of maintenance are a brush and a common vacuum cleaner or an air compressor.

periodic maintenance lamp

The lamp should be replaced if there is any observable damage or deformation due to heat. This will avoid the danger of the lamp exploding.

mechanicals

Periodically check all mechanical devices for wear and tear; gears, guides, belts, etc., replacing them if necessary. Periodically check the lubrication of all components, particularly the parts subject to high temperatures. If necessary, lubricate with suitable lubricant, available from your **coemar** distributor.

electrical components

Check all electrical components for correct earthing and proper attachment of all connectors, refastening if necessary.

fuse replacement

Locate the fuse, which protects the lamp and electronics, in the base of the **ProSpot 575 LX**. Using a multimeter, test the condition of the fuse, replacing it with one of equivalent type if necessary.

19. Electronic motor alignment

INSTALLER INSTRUCTIONS ONLY

The display panel at the rear of the **ProSpot 575 LX** allows for the electronic alignment of the projector's motors in the optical system. This procedure is performed by **coemar** at the factory. It may be useful to perform this procedure in the case of internal components being replaced.

Altering the factory settings may radically alter the functioning of the projector. Carefully read all of the following prior to attempting any changes.

electronic calibration

Important Note: electronic calibration is only possible if the projector is connected to a **DMX 512** source.

- 1) Press the menu button.
- 2) Press the + or - button until the display shows **RESE** (for reset).
- 3) Press the enter button to confirm your selection then immediately and simultaneously press and hold the **menu** button, holding both pressed for at least **30** seconds. The motors of the unit will perform a reset and the display will show **----** for some few seconds, indicating that you have entered the electronic calibration mode.



Note: Simultaneously pressing the **+** and **-** buttons will return the calibration value to the default value of 128.

20. Spare parts

All the components of the **ProSpot 575 LX** are available as replacement spares from your authorised **coemar** sales agent. Accurate description of the fixture, model number, and type will assist us in providing for your requirements in an efficient and effective manner.