

REVISION HISTORY

SCH REV	PCB REV	ECO NO.	DATE	COMMENT
- 1.0	- 1.0	-		

NOTES :

UNLESS OTHERWISE SPECIFIED :

1. ALL RESISTOR VALUES ARE IN OHMS
2. ALL RESISTORS ARE 1/4 WATT 5% OR BETTER
3. CAPACITOR VALUES ARE IN PICO FARADS
4. ALL NON POLARIZED CAPACITORS ARE 50V OR BETTER
VALUES BELOW 470pF ARE NPO/COG TYPE 5%
VALUES 470pF TO 1000pF ARE X7R 10%
VALUES ABOVE 1000pF ARE Z5U +/- 20 %
5. ALL POLARIZED CAPACITORS ARE 20% OR BETTER

Copyright (c) 1994-2001 High End Systems, Inc. All rights reserved worldwide.

Lightwave Research, the Lightwave Research logo, High End Systems and the High End Systems logo are registered trademarks of High End Systems, Inc. Trademarks and trade names of others may be used in this document to refer to either such other entities or to their products. High End Systems Inc. disclaims any proprietary interest or connection to such marks or entities.

HIGH END SYSTEMS INC.			
Title:		MOTOR DRIVER MODULE 3773 X4	
Function:		125R101	
Drawing No.	REV.	Designed:	
SCH-99030125	1.0.1	ENGINEER	
Drawn:		Approved:	
DRAWER			
2-5-2001-16.50	Size A2	Page 1	OF 8



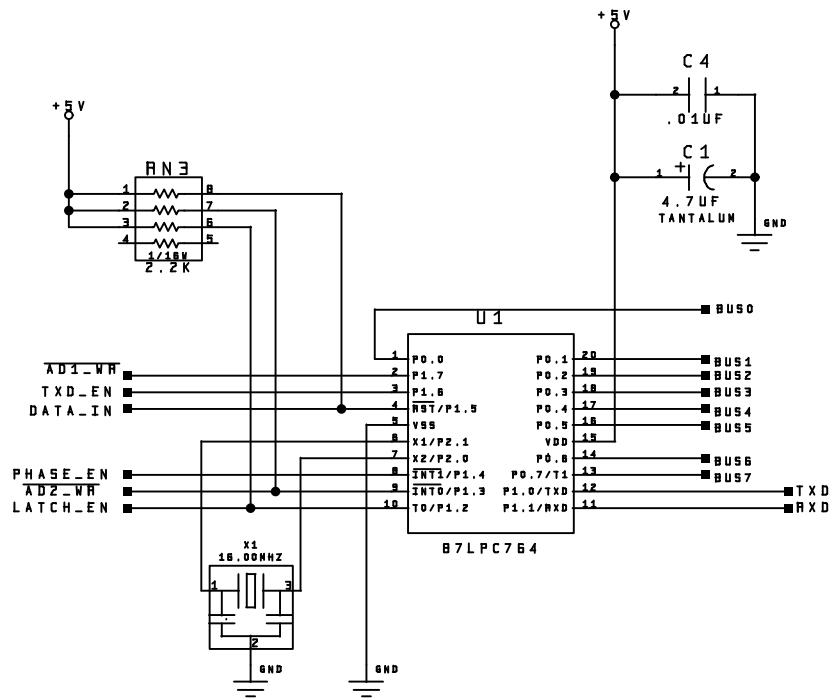

HIGH END SYSTEMS INC.

Title:
MOTOR DRIVER MODULE 3773 X4



Function:
DRIVER MODULE CPU 125R101

Drawing No.
SCH-99030125

REV.
1.0.1

Size A2

2-28-2001-B143
Page 2 of 8

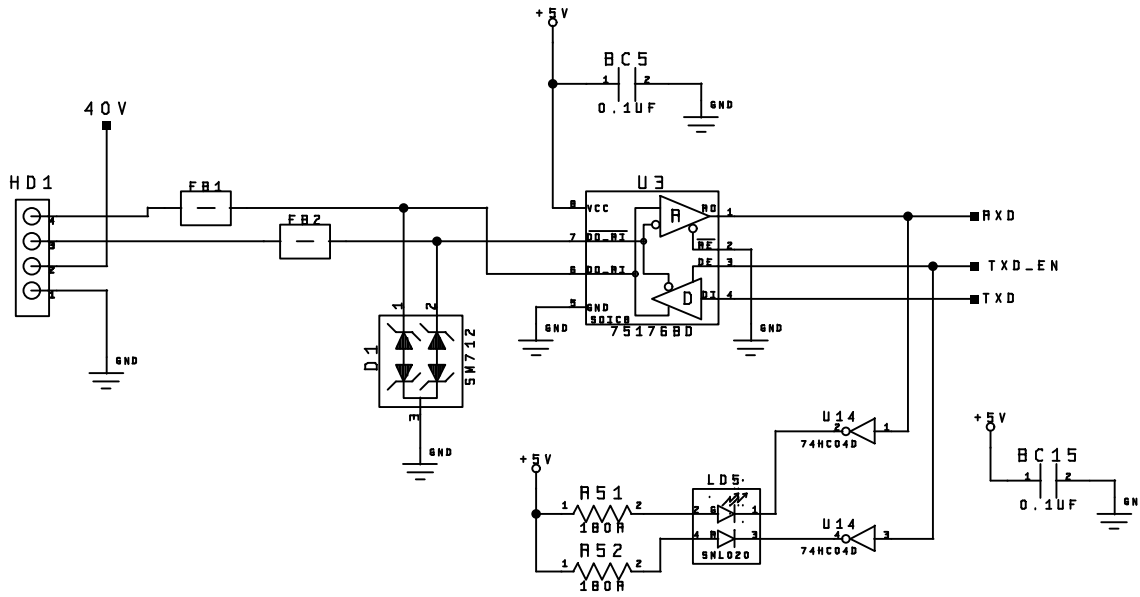
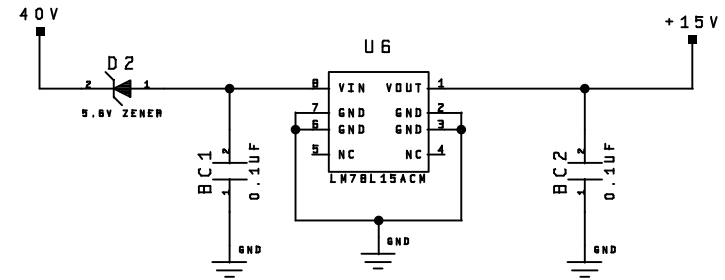
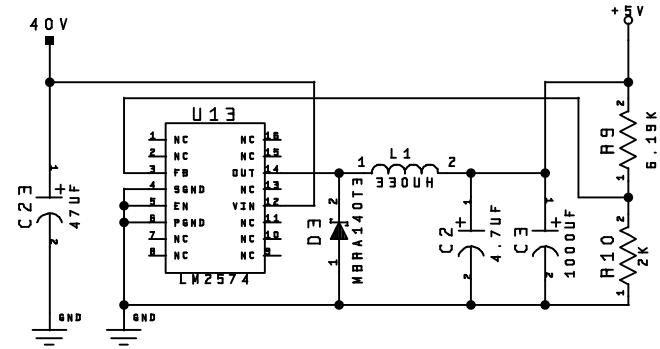
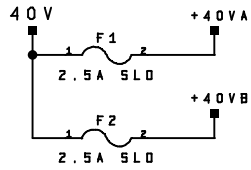

HIGH END SYSTEMS INC.

Title:
MOTOR DRIVER MODULE 3773 X4



Function:
DRIVER MODULE POWER 125R101

Drawing No.
SCH-99030125

REV.
1.0.1

Size A2

3-20-2001-13:41
Page 3 of 8

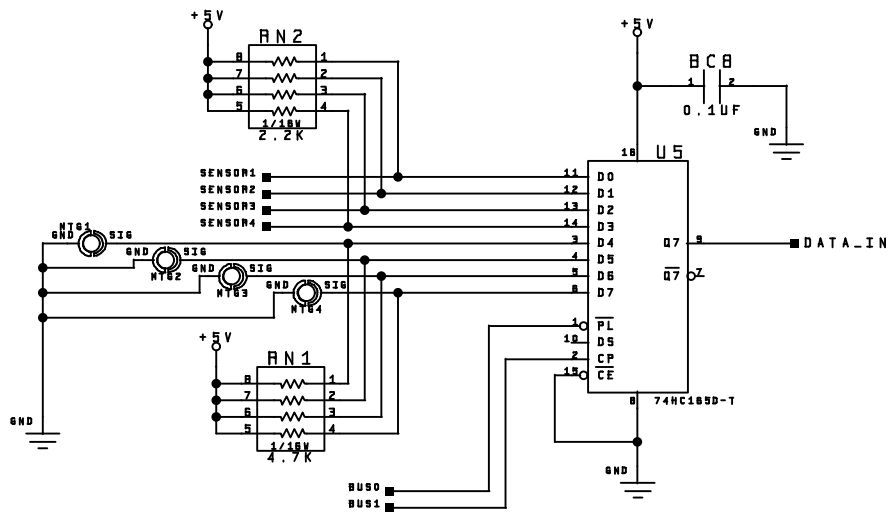
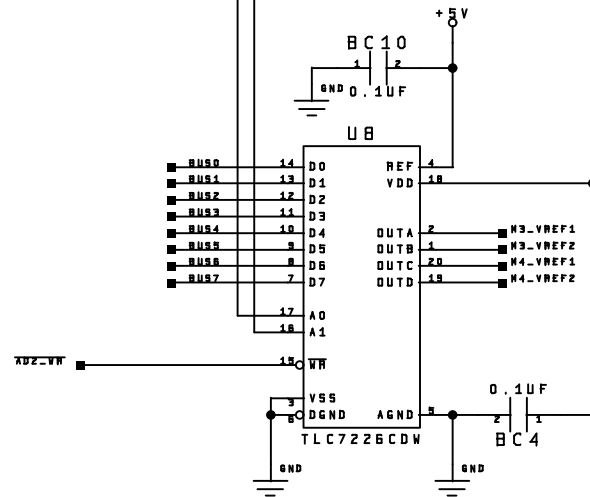
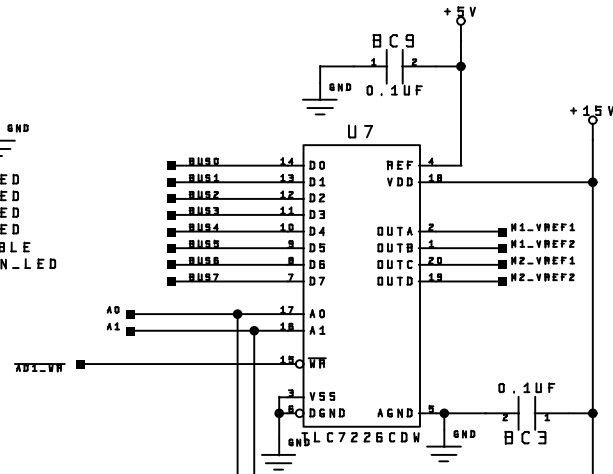
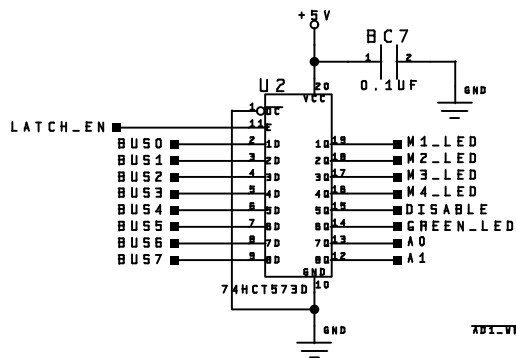
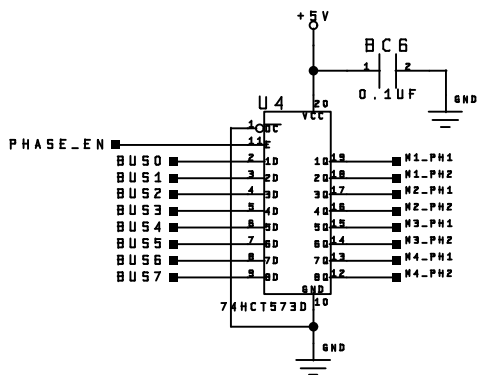

HIGH END SYSTEMS INC.

Title:
MOTOR DRIVER MODULE 3773 X4

Function:
DRIVER MODULE INTERFACE#25R101

Drawing No.
SCH-99030125

REV.
1.0.1

Size A2

2-5-2001_16_50

Page 4 of 8



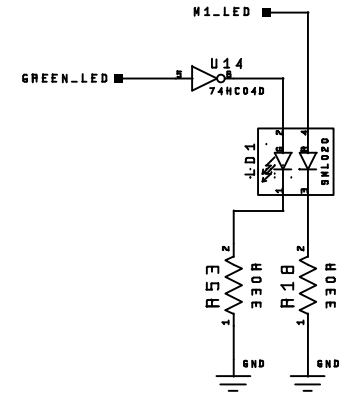
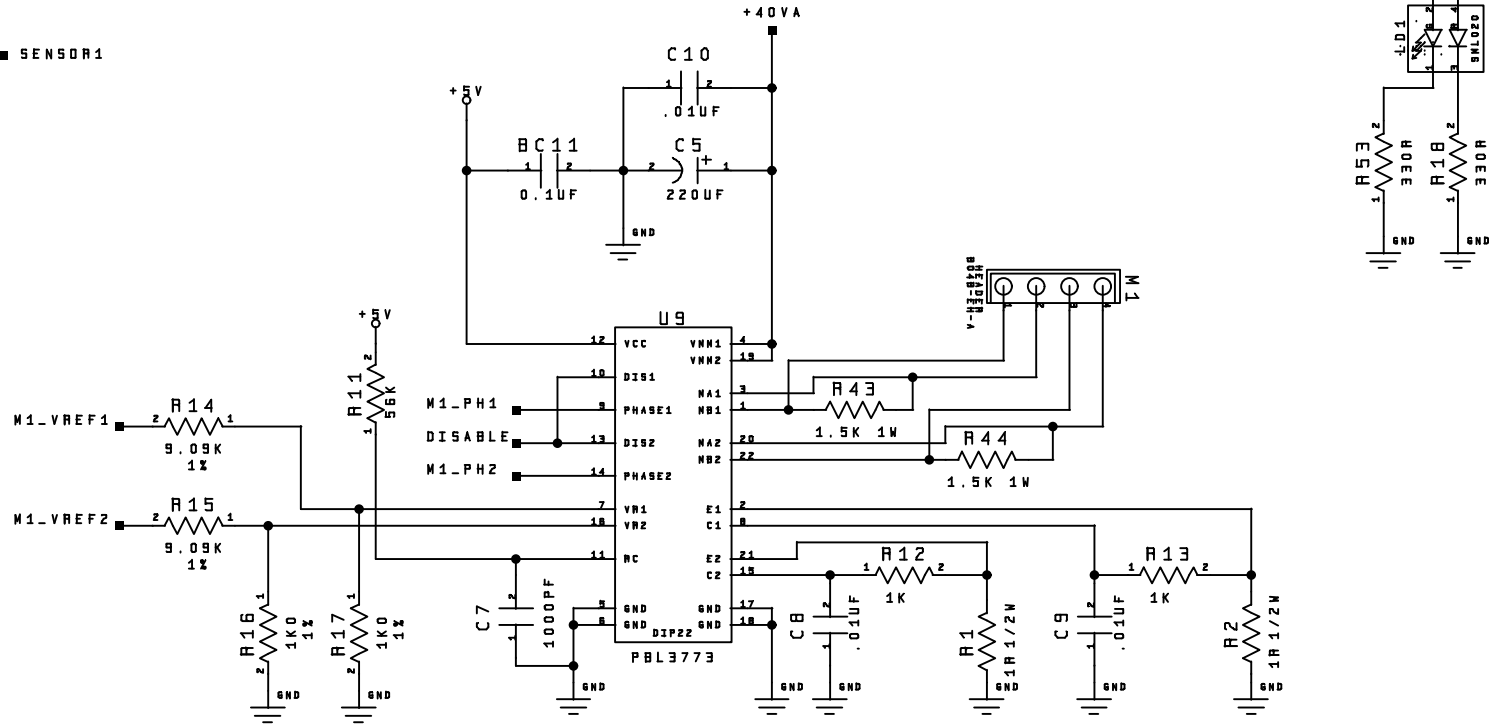
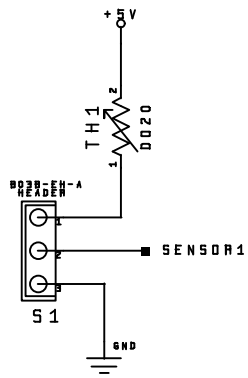

HIGH END SYSTEMS INC.			
Title:		MOTOR DRIVER MODULE 3773 X4	
Function:		DRIVER MODULE #1 125R101	
Drawing No.	REV.	2-5-2001_16:50	
SCH-99030125	1.0.1	Size A2	Page 5 of 8



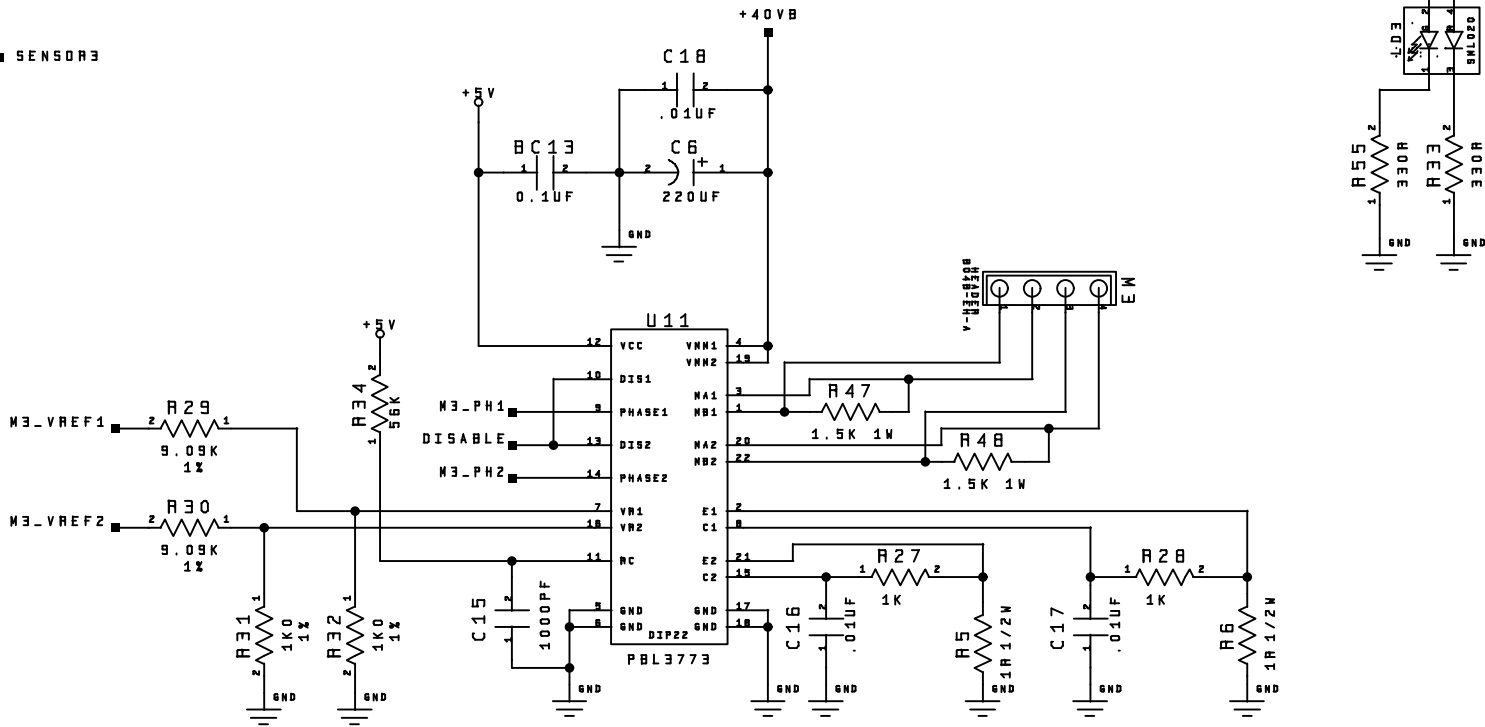
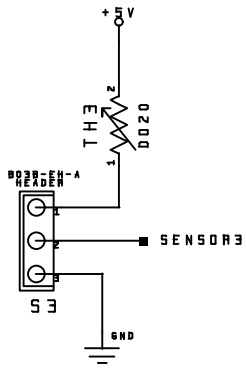

HIGH END SYSTEMS INC.

Title: MOTOR DRIVER MODULE 3773 X4

Function: DRIVER MODULE #3125R101

Drawing No. SCH-99030125

REV. 1.0.1

Size A2

2-5-2001_16:50
Page 7 of 8



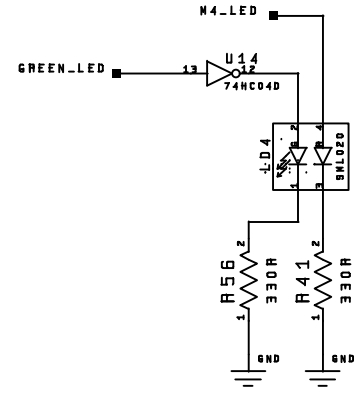
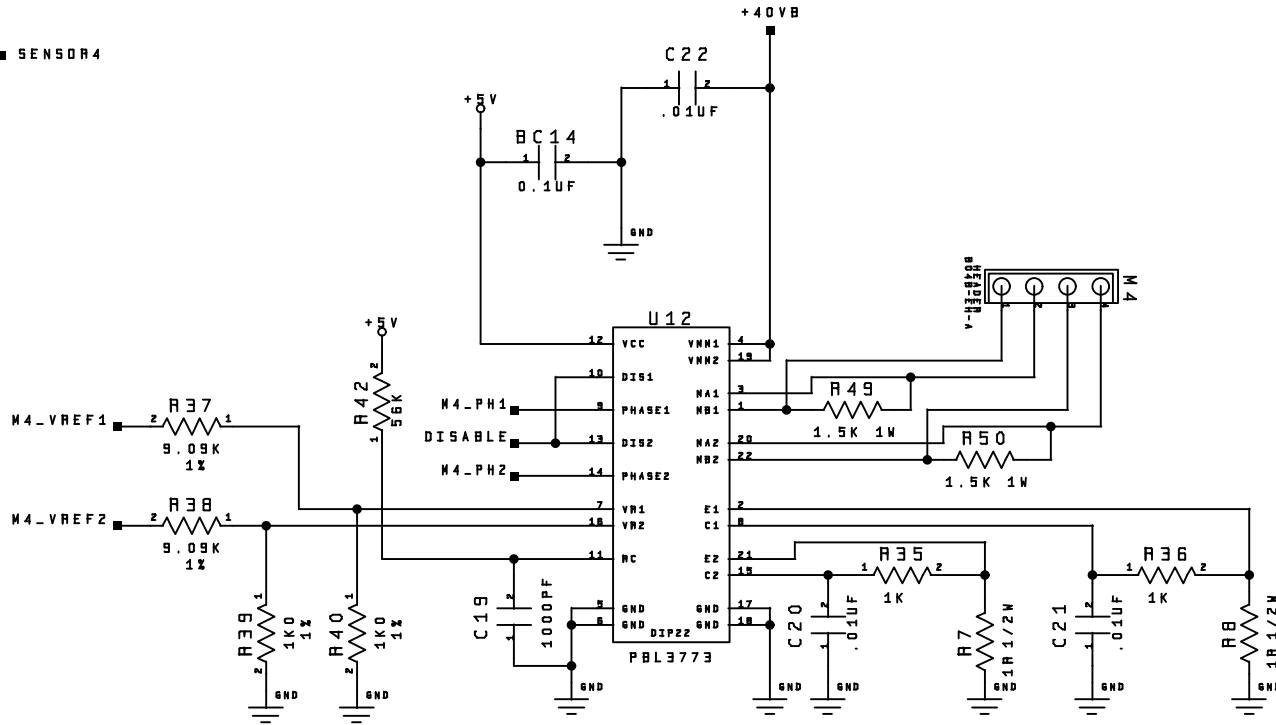
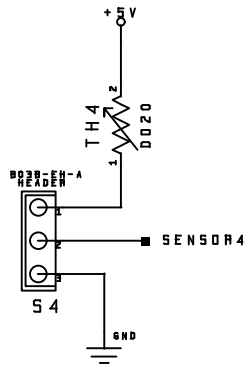

HIGH END SYSTEMS INC.

Title: MOTOR DRIVER MODULE 3773 X4

Function: DRIVER MODULE #4 125R101

Drawing No. SCH-99030125

REV. 1.0.1

Size A2

2-5-2001_16:50

Page 8 of 8

