



FUZE WASH Z350™

SKU# FUZ035

The FUZE WASH Z350™ is a single source par moving head luminaire with a 350W Quad Color RGBW COB LED. Features 6° to 46° motorized zoom, pan and tilt, RGBW color mixing, electronic strobe and selectable dimming curve effects, DMX and RDM (remote device management) protocol support, DMX and power in/out connections, LCD menu display with 7 button control panel, multiple unit power linking, flicker free operation for TV and FILM, and a multi-voltage universal auto switching power supply (110-240v).

FEATURES

350W RGBW COB LED Moving Head Wash Luminaire

RGBW Color Mixing

6° to 46° Motorized Zoom Range

Variable Dimming Curves

Multiple Unit Power Linking

RDM (Remote Device Management)

Flicker Free Operation for TV and FILM

Optional Snoot Lens



PRODUCT SPECIFICATIONS

SOURCE

350W RGBW COB LED
100,000 Hour Average LED Life*

*May vary depending on several factors including but not limited to:
Environmental Conditions, Power/Voltage, Usage Patterns (On-Off Cycling), Control and Dimming.

PHOTOMETRIC DATA

60,280 LUX 5,600 FC @6.6' (2m) (6° Full ON)
3,735 LUX 347 FC @6.6' (2m) (46° Full ON)

EFFECTS

RGBW Color Mixing
6° - 46° Beam Zoom Range
Electronic Strobe and Variable Dimming Curves
64 Color Presets and 14 Unique Color Macros

COLOR

RGBW

CONTROL / CONNECTIONS

4 DMX Channel Modes (19 Total Channels)
7 Button Control Panel and LCD Menu Display
RDM (Remote Device Management)
3pin/5pin DMX and powerCON In/Out

SIZE / WEIGHT

Length: 16.3" (414mm)
Width: 11.6" (294mm)
Vertical Height: 18.0" (461mm)
Weight: 43 lbs. (19.5 kg)

ELECTRICAL / THERMAL

AC 110-240V - 50/60Hz
399W Max Power Consumption
Multiple Unit Power Linking
5°F to 113°F (-15°C to 45°C)

INCLUDED ITEMS

Omega Brackets
powerCON Power Cable

APPROVALS / RATINGS



Optional Snoot Available



PHOTOMETRIC DATA

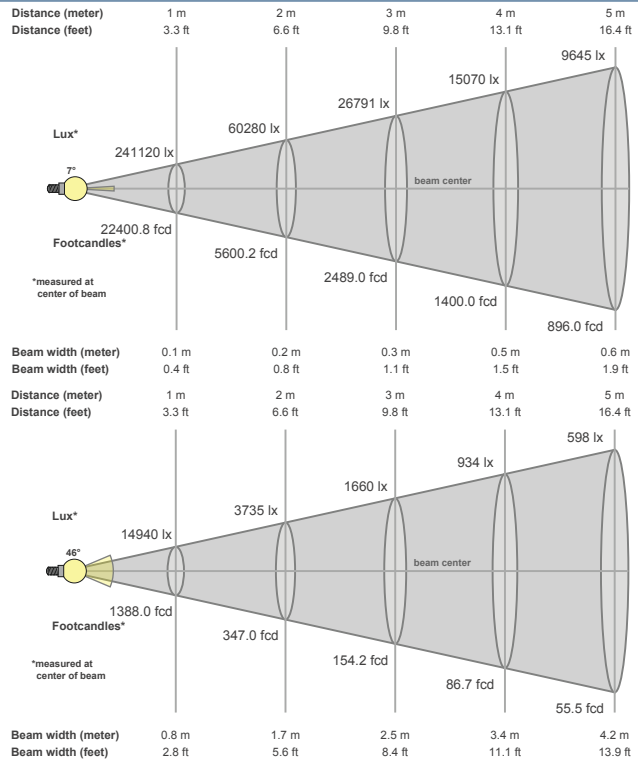

DIMENSIONAL DIAGRAMS

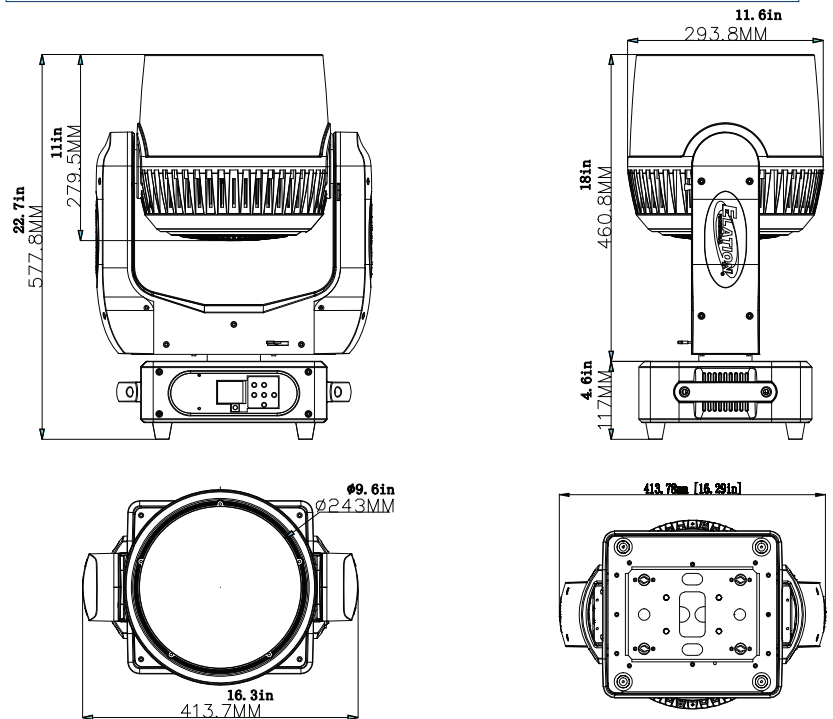

OPTIONAL ACCESSORIES

ORDER CODE	ITEM
FW350SNOOT	FUZE WASH Z350 Snoot
TRIGGER CLAMP	Heavy Duty Wrap Around Hook Style Clamp
AC3PDMX5PRO	5 ft. (1.5m) 3pin PRO DMX Cable (Additional cable lengths available)
AC5PDMX5PRO	5 ft. (1.5m) 5pin PRO DMX Cable (Additional cable lengths available)
PLC3	3 ft. (1m) PowerCON TRUE1 Power Link Cable
DRC350FUZE	Quad Road Case for FUZE WASH Z350

Specifications are subject to change without notice ©Elation Professional 04/19/17

