

REV.	DESCRIPTION	DATE	ENG	ECO #	APPR
1	CREATE DRAWING	23JUN09	PP		
2	ADD IX 90701013 & IX 90701161	15SEP09	PP		
3	REMOVE 2X 90410066, ADD 2X 90410165EF	12OCT09	PP		
4	REV CHANGE TO ITEM 5	19OCT09	PP		
5	REV CHANGE ITEM 5	02NOV09	PP		
6	REV CHANGE ITEM 4	18NOV09	PP		

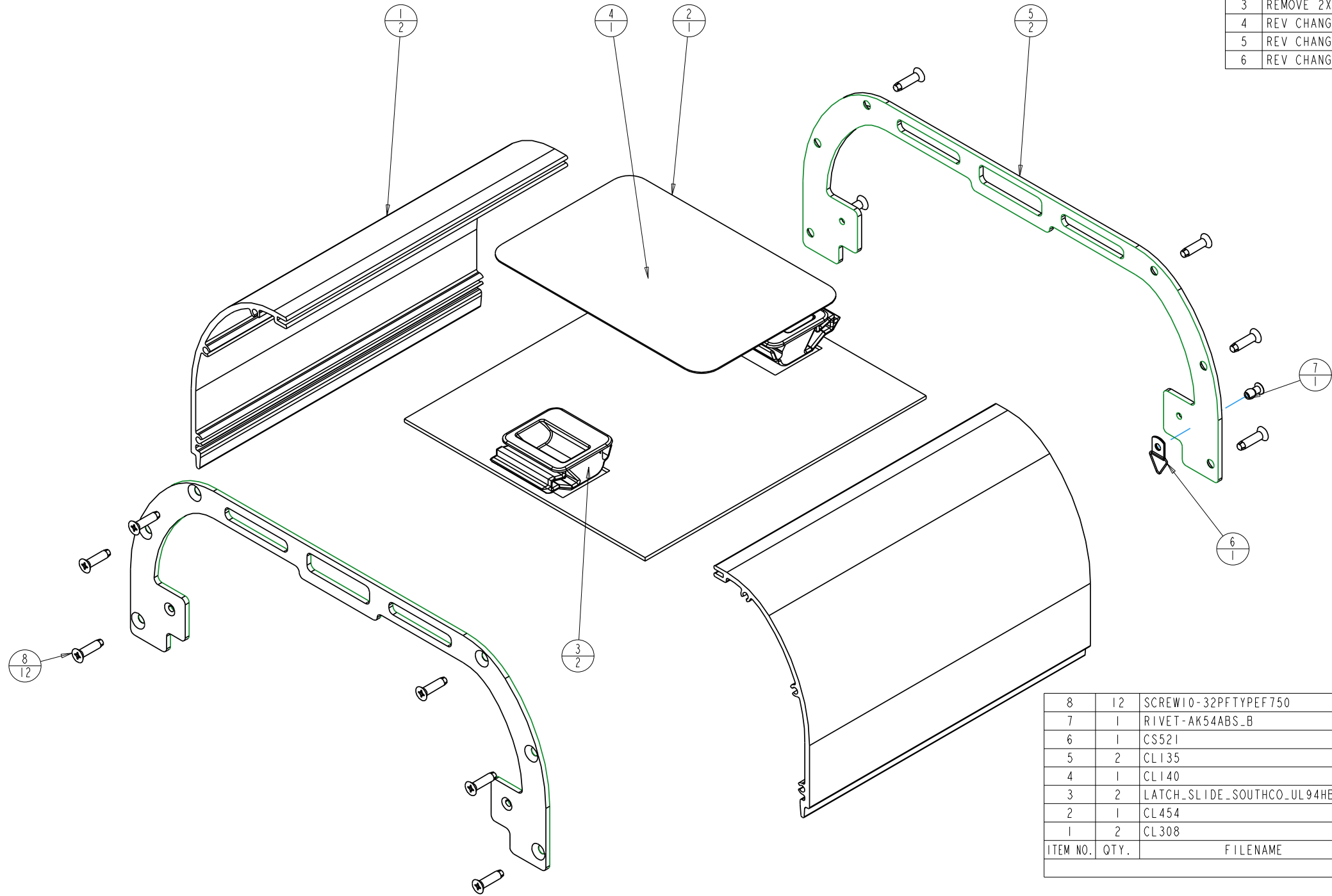

ITEM NO.	QTY.	FILENAME	PART NO.	REV	DESCRIPTION
8	12	SCREW10-32PFTYPEF750	90711018	.	SCREW,10-32 PHIL FLAT 3/4 F TYPE BZ
7	1	RIVET-AK54ABS_B	90701161	.	RIVET,5/32 CSK .188 - .250 AL BLK PAINT
6	1	CS521	90701013	.	RING,D EM,IB,TS,AF
5	2	CL135	80070549	A	PLT,END CAP,CVR,FRONT
4	1	CL140	80070552	A	PLT, MIDCOVER
3	2	LATCH_SLIDE_SOUTHCO_UL94HB	90410165EF	.	LATCH, SOUTHCO, PUSH TO CLOSE, LOW TEMP
2	1	CL454	99310525	A	LABEL,MID COVER
1	2	CL308	80070556	-	EXTR,CVR,OPTICS,MACHINED
BILL OF MATERIALS					

UNLESS OTHERWISE SPECIFIED DIMENSIONAL TOLERANCES: 0 PLACE DECIMAL = ±0.38 1 PLACE DECIMAL = ±0.25 2 PLACE DECIMALS = ±0.13 ANGLES = ±0.5°	RELEASE DATE: ENG: PETE PHILLIPS	CE: QA:	High End 2105 GRACY FARMS LANE AUSTIN, TEXAS 78758 (512) 836-2242 FAX (512) 832-4128 http://www.highend.com	
	FOR PAINTED PARTS REFER TO ENG. SPEC. MANUAL WI-0592	ME: MFG: DRW: PETE PHILLIPS		
ALL COMPONENTS, MATERIALS AND FINISHES TO BE RoHS COMPLIANT	MATERIAL: CHARTED	FINISH: NA		
MIN. DRAFT MIN. RADI FLATNESS THICKNESS VOLUME	INTERPRET DIMENSIONS PER ASME Y14.5M-1994 THIRD ANGLE PROJECTION DIMENSIONS ARE IN MILLIMETERS		PART NO. INTERNAL	DRAWING NO. CLA033
		DO NOT SCALE	SCALE: 0.500	SHEET: 1 OF 1
				REV. 6

PROPRIETARY NOTICE:
 THIS DOCUMENT CONTAINS CONFIDENTIAL AND PROPRIETARY INFORMATION OF HIGH END SYSTEMS INC., (ALSO DBA LIGHTWAVE RESEARCH) AND IS GIVEN TO THE RECEIVER IN CONFIDENCE. THE RECEIVER ACCEPTS AND AGREES THAT, EXCEPT AS AUTHORIZED BY HIGH END SYSTEMS, THE RECEIVER WILL NOT PERMIT THE USE OF THE DOCUMENT OR ANY COPY THEREOF OR THE INFORMATION THEREIN, WILL NOT COPY OR PERMIT COPYING THE DOCUMENT WILL NOT DISCLOSE TO OTHERS EITHER THE DOCUMENT OR THE INFORMATION THEREIN, AND WILL UPON COMPLETION OF THE NEED TO RETAIN THE DOCUMENT, OR UPON DEMAND, RETURN THE DOCUMENT WITHOUT RETAINING ANY OF THE INFORMATION CONTAINED THEREIN IN ANY FORM WHATSOEVER.