

Manua1



Service



VL1000™ ERS Luminaire

02.9663.0010

PHILIPS

VARI*LITE

VARI*LITE® - VL1000™ ERS LUMINAIRE SERVICE MANUAL

VARI*LITE® is a trademark owned by Genlyte Thomas Group LLC and is registered in the United States and other countries. VL500™, VL1000™, VL2000™, VL2201™, VL2202™, VL2400™ (and the individual product designations), VL3000™, VL3500™, Series 500™, series 1000™, Series 2000™, Series 3000™, DICHRO*TUNE™, VARI*IMAGE™, VARI*BRITE™, and the Vari-Lite Asterisk are also trademarks owned by Genlyte Thomas Group LLC.

VARI*LITE® products are protected by one or more of the following patents, and other pending patent applications worldwide:

U. S. Patents No. 6,123,436; 6,113,252; 6,046,861; 6,031,749; 6,011,640; 5,969,868; 5,959,768; 5,934,794; 5,882,107; 5,829,868; 5,825,548; 5,798,619; 5,774,273; 5,769,527; 5,758,956; 5,728,994; 5,640,061; 5,590,954; 5,454,477; 5,432,691; 5,367,444; 5,329,431; 5,307,295; 5,282,121; 5,278,742; 5,209,560; 5,186,536; 5,073,847; 5,010,459; 4,980,806; 4,972,306; 4,800,474; 4,779,176; 4,701,833; 4,602,321;

U. S. Design Patents No. 439,356; 420,332; 417,300; 415,301; 413,995; 377,338; 366,712; 359,574; 350,408; 347,113;

Australia Patents No. 693,691; 683,695; 667,109; 649,264; 646,588; 586,095; 576,400; 546,433;

Australia Design Patents No. 128,796; 128,795;

Canada Patents No. 2,070,670; 2,050,375; 1,270,675; 1,259,058; 1,181,795;

Canada Design Patents No. 81,234; 81,233; 76,046;

European (UK) Patents No. 0 652 400; 0 586 049; 0 565 218; 0 547 732; 0 534 710; 0 495 305; 0 474 202; 0 379 970; 0 253 082; 0 253 081; 0 248 974; 0 192 882; 0 140 994; 0 060 068;

Germany Patents No. 694 25 943.8; 693 14 122.0; 692 08 615.3; 692 07 692.1; 691 31 478.0; 691 21 029.2; 690 33 385.4; 37 89 166.9; 37 68 727.1; 37 51 804.6; 37 50 201.8; 35 87 270.5; 32 79 888.1; 32 74 291.6;

Germany Design Patents No. M 98 01 745.4; M 96 04 515.9; M 96 04 514.0; M 94 07 689.8; M 94 02 951.2; M 499 03 583.6; M 498 11 203.9; G 93 12 884.3;

Spain Patents No. 2 090 191; 2 084 289; 2 020 960; 0 548 328;

Spain Utility Model Patent No. 2.031.748;

Spain Design Patents No. 0.137.502; 0.137.501; 0.133.573;

Greece Patent No. 910.400.544;

Hong Kong Patents No. 965/1990; 285/1987;

Japan Patents No. 2,843,696; 2,059,669; 2,055,324; 2,002,168; 1,966,525; 1,889,481; 1,792,721; 1,770,241; 1,723,825; 1,683,007; 1,533,011;

Japan Design Patents No. 985,985-1; 985,985; 947,552; 945,436-1; 945,436; 1,106,089; 1,077,598; 1,072,598; 1,060,414; 1,002,123;

Korea Patents No. 76,310; 42,639; 283,770; 181,180;

Korea Design Patents No. 209,896; 209,895;

Mexico Patent No. 180,148;

Singapore Patents No. 663/90; 134/87;

Taiwan Patents No. 78,726; 66,975; 65,380; 28,275;

United Kingdom Design Registrations No. 2082526; 2072562; 2056387; 2056386; 2042174; 2038212; 2033108; 2029499.

Neutrik®, PowerCon®, and EtherCon® are registered trademarks of Neutrik, Inc.

All other brand or product names which may be mentioned in this manual are trademarks or registered trademarks of their respective companies or organizations.

VL1000™ ERS Luminaire Service Manual

The information furnished in this manual is for informational use only and is subject to change without notice. Please check www.vari-lite.com for latest version. Vari-Lite assumes no responsibility or liability for any errors or inaccuracies that may appear in this manual. All information and graphics are property of Vari-Lite, 10911 Petal Street, Dallas, Texas 75238.

Version as of: **14-May-2009**

Part number: **02.9663.0010 F**

VL1000™ ERS Luminaire Service Manual

©2002-2009, Vari-Lite, a Philips group company. All Rights Reserved.

How To Obtain Warranty Service

A copy of the Vari-Lite Limited Warranty was included in the shipping package for this VARI*LITE® product.

To obtain warranty service, please contact customer service at 1-877-VARI-LITE (1-877-827-4548) or customerservice@genlytecontrols.com and request a Return Material Authorization (RMA) for warranty service. You will need to provide the model and serial number of the item being returned, a description of the problem or failure and the name of the registered user or organization. If available, you should have your sales invoice to establish the date of sale as the beginning of the warranty period.

Once you obtain the RMA, pack the unit in a secure shipping container or in its original packing box. Fill out the RMA form included at the end of this manual and place in shipping container along with a copy of your invoice (if available). Write the RMA number legibly on or near the shipping address label and return the unit, freight prepaid to:

Vari-Lite
10911 Petal Street
Dallas, Texas 75238 USA
Attention: Warranty Service

As stated in the warranty, it is required that the shipment be insured and FOB our service center.

Manual Revision History

PAGE NUMBER	CHANGE NUMBER
Title Page – xviii	F
1-205	F

VERSION	DATE
Basic	14-March-02
Revision A	25-April-02
Revision B	02-May-02
Revision C	18-June-02
Revision D	23-October-02
Revision E	25-March-04
Revision F	14-May-2009

Compliance Notice

FCC This equipment has been tested and found to comply with the limits for a Class A digital device pursuant to Part 15 of FCC Rules. These limits are designed to provide reasonable protection against harmful interference when this equipment is operated in a commercial environment. This equipment generates, uses, and can radiate radio frequency energy and, if not installed and used in accordance with Vari-Lite system, service, and safety guidelines, may cause harmful interference to radio communications. Operation of this equipment in a residential area is likely to cause harmful interference, in which case the user will be required to correct the interference at his/her own expense.

CE Declaration of Conformity

We declare, under our sole responsibility, that this product complies with the relevant clauses of the following standards and harmonized documents (as applicable):

Safety:

(by Council Directive 73/23/EEC)

EN60598-1: 1997/A1:1998

EN60598-2-17: 1989/A2:1991

EN60922

Electromagnetic Compatibility:

(by Council Directive 89/336/EEC)

EN55022:1998, Class A

EN61000-4-2: 1995, Performance Criteria: B

EN61000-4-3: 1995, Performance Criteria: A

EN61000-4-4: 1995, Performance Criteria: B

EN61000-4-5: 1995, Performance Criteria: B

EN61000-4-6: 1996, Performance Criteria: A

EN61000-4-8: 1996, Performance Criteria: A

EN61000-4-11: 1994, Performance Criteria: B and C

EN61000-3-2: 1995

EN61000-3-3: 1994

We certify that the product conforms to the protection requirements of council directives: 73/23/EEC (LVD) and 89/336/EEC (EMC)

Safety Notice

It is extremely important to read ALL safety information and instructions provided in this manual and any accompanying documentation before installing and operating the products described herein. Heed all cautions and warnings during installation and use of this product.

Safety symbols used throughout this manual are as follows:



CAUTION advising of potential damage to product.



WARNING advising of potential injury or death to persons.

GENERAL INFORMATION PERTAINING TO PROTECTION AGAINST ELECTRICAL SHOCK, FIRE, EXPOSURE TO EXCESSIVE UV RADIATION, AND INJURY TO PERSONS CAN BE FOUND BELOW.

WARNING:

INSTRUCTIONS FOR CONTINUED PROTECTION AGAINST FIRE

1. VARI*LITE® luminaires have been designed for use only with certain Philips and Osram HID lamps. Note lamp type (MSR400, MSR575HR etc.) before replacing lamps. Installing another type of lamp may be hazardous.
2. Luminaires may be mounted on any type of surface as long as mounting instructions are followed. See instructions detailed in this manual.
3. Replace fuses with same type and rating only.
4. Note distance requirement from combustible materials or illuminated objects for VARI*LITE® luminaires.

WARNING:

INSTRUCTIONS FOR CONTINUED PROTECTION AGAINST ELECTRICAL SHOCK

1. VARI*LITE® luminaires are designed for dry locations only. Exposure to rain or moisture may damage luminaire.
2. Disconnect power before servicing any VARI*LITE® equipment.
3. Servicing to be performed by qualified personnel only.



WARNING: It is not recommended to power any VARI*LITE® luminaire from a dimmer - even in 'NONDIM' mode. Dimmer and non-dim modules are not suitable sources of power because their output modifies the AC wave form. This may work for a short time, but will eventually result in power problems, luminaire mis-operation and/or failure. See Vari-Lite Technical Notice TN-229A for more information.

**WARNING:
INSTRUCTIONS FOR CONTINUED PROTECTION AGAINST EXCESSIVE
EXPOSURE TO UV RADIATION**

1. Many VARI*LITE® luminaires use an HID type lamp that produces UV radiation. DO NOT look directly at lamp.
2. It is hazardous to operate luminaires without lens or shield. Shields, lenses, or ultraviolet screens shall be changed if they have become visibly damaged to such an extent that their effectiveness is impaired. For example, by cracks or deep scratches.

**WARNING:
INSTRUCTIONS FOR PROTECTION AGAINST INJURY TO PERSONS**

1. Exterior surfaces of the luminaire will be hot during operation. Use appropriate safety equipment (gloves, eye protection, etc.) when handling and adjusting hot equipment and components.
2. Luminaires will have a hot lamp when operating. Disconnect power and allow lamp to cool before replacing.
3. Arc lamps emit ultraviolet radiation which can cause serious skin burn and eye inflammation. Additionally, arc lamps operate under high pressure at very high temperatures. Should the lamp break, there can exist a danger of personal injury and/or fire from broken lamp particles being discharged.
4. Wear eye protection when relamping.
5. Appropriate safety equipment (gloves, eye protection) should be used when handling damaged lamps.
6. If lamp is touched with bare hands, clean lamp with denatured alcohol and wipe with lint-free cloth before installing or powering up the luminaire.
7. The lamp shall be changed if it has become damaged or thermally deformed.

**WARNING:
RF INTERFERENCE**

1. This is a Class A product. In a domestic environment this product may cause radio interference, in which case, the user may be required to take adequate measures.

ARC LAMP CHARACTERISTIC CONSIDERATIONS

1. Arc lamps require a period of time to relight after a power interruption or a severe voltage dip. In some cases, lamp will automatically relight after it has cooled depending on Lamp Power-Up State (L ON/ LOFF) system configuration setting.
2. Burning position is Universal.

Sicherheitshinweise

Es ist äußerst wichtig, ALLE Sicherheitsinformationen und -hinweise in diesem Handbuch und dem beiliegenden Informationsmaterial zu lesen, bevor Sie die hierin beschriebenen Produkte installieren bzw. bedienen. Halten Sie bei der Installation und dem Einsatz dieses Produkts alle Warnhinweise und Vorsichtsmaßnahmen ein.

Folgende Sicherheitssymbole werden in diesem Handbuch verwendet:



VORSICHT - weist auf möglichen Produktschaden hin.



WARNUNG - weist auf mögliche Körperverletzung und Lebensbedrohung hin.

NACHSTEHEND FINDEN SIE ALLGEMEINE HINWEISE ÜBER SICHERHEITSVORKEHRUNGEN GEGEN ELEKTROSCHOCK, FEUER, ÜBERHÖHTE UV-STRAHLUNG UND KÖRPERVERLETZUNGEN.

WARNUNG:

HINWEISE ZUM FEUERSCHUTZ

1. VARI*LITE®-Scheinwerfer sind ausschließlich für den Einsatz mit bestimmten Philips und Osram HID-Lampen geeignet. Achten Sie auf den Lampentyp (MSR400, MSR575HR etc.), bevor Sie die jeweiligen Lampen ersetzen. Die Installation eines anderen Lampentyps kann gefährlich sein.
2. Scheinwerfer können auf jeder beliebigen Oberfläche montiert werden, solange Sie die Montageanweisungen befolgen. Detaillierte Hinweise finden Sie in diesem Handbuch.
3. Ersetzen Sie Sicherungen nur mit Sicherungen vom gleichen Typ und gleicher Stärke.
4. Beachten Sie die Einhaltung des erforderlichen Sicherheitsabstandes der VARI*LITE®-Scheinwerfer von brennbarem Material oder beleuchteten Objekten.

WARNUNG:

HINWEISE ZUM SCHUTZ GEGEN ELEKTROSCHOCK

1. VARI*LITE®-Scheinwerfer eignen sich ausschließlich für trockene Standorte. Regen oder Feuchtigkeit können die Scheinwerfer beschädigen.
2. Unterbrechen Sie die Stromzufuhr, bevor Sie mit der Arbeit an VARI*LITE®-Geräten beginnen.
3. Die Geräte sollten nur von qualifiziertem Personal gewartet werden.

WARNUNG:

HINWEISE ZUM SCHUTZ GEGEN ÜBERHÖHTE UV-STRAHLUNG

1. Viele VARI*LITE®-Scheinwerfer verwenden einen HID-Lampentyp, der UV-Strahlen abgibt. SCHAUEN SIE NICHT direkt in die Lampe.

2. Es ist gefährlich, Leuchten ohne Linsen oder Blenden zu bedienen. Blenden, Linsen oder Ultraviolettsschirme müssen ausgetauscht werden, sofern deren Schutzwirkung durch sichtbare Beschädigung (z. B. Sprünge oder Schrammen) eingeschränkt ist.

WARNUNG:

HINWEISE ZUM SCHUTZ GEGEN KÖRPERVERLETZUNGEN

1. Bei Betrieb sind die Außenflächen der Scheinwerfer heiß. Verwenden Sie bei der Bedienung von aufgeheizter Apparatur die jeweils geeignete Sicherheitsausrüstung (Handschuhe, Augenschutz etc.).
2. Bei Betrieb der Scheinwerfer ist die Lampe heiß. Unterbrechen Sie die Stromzufuhr und lassen Sie die Lampe abkühlen, wenn Sie diese austauschen.
3. Bogenlampen senden ultraviolette Strahlen aus, die Hautverbrennungen und Augenentzündungen verursachen können. Der Betrieb von Bogenlampen erfolgt unter Hochdruck und bei hohen Temperaturen. Sollte die Lampe zerbrechen, besteht die Gefahr von Körperverletzung bzw. von Feuer, das von Lampenteilen ausgelöst werden kann.
4. Tragen Sie beim Austausch der Lampen einen Augenschutz.
5. Die geeignete Sicherheitsausrüstung (Handschuhe, Augenschutz) sollte beim Umgang mit beschädigten Lampen verwendet werden.
6. Wenn die Lampe mit bloßen Händen berührt wird, reinigen Sie sie mit denaturiertem Alkohol und einem flusenfreien Tuch, bevor Sie die Scheinwerfer installieren oder in Betrieb nehmen.
7. Wenn die Lampe beschädigt oder durch Hitzeeinwirkung deformiert ist, muß diese ausgetauscht werden.

WARNUNG:

HF-INTERFERENZ

1. Es handelt sich um ein Produkt der Klasse A. In einer Wohnumgebung kann das Produkt Hochfrequenzstörungen verursachen. In diesem Fall müssen eventuell geeignete Maßnahmen getroffen werden.

BESONDERHEITEN VON BOGENLAMPEN

1. Bogenlampen benötigen eine gewisse Zeitdauer, um nach einem Stromausfall oder einem Spannungsgefälle wieder aufzuleuchten. In einigen Fällen wird die Lampe nach Abkühlung automatisch wieder aufleuchten, je nach der Systemkonfigurationseinstellung des Lampeneinschaltungsstatus (L ON/ LOFF).
2. Die Brennposition ist Universal.

Notes de sécurité

Avant de procéder à l'installation des produits décrits dans ce guide et de les mettre en marche, il est extrêmement important de lire TOUS les renseignements et TOUTES les directives de sécurité contenues dans ce guide ainsi que toute documentation jointe. Tenir compte de tous les avertissements et suivre toutes les précautions pendant l'installation et l'utilisation de cet appareil.

Les symboles de sécurité utilisés dans ce guide sont les suivants :



ATTENTION Ce symbole annonce que l'appareil risque d'être endommagé.



AVERTISSEMENT Ce symbole annonce qu'il y a risque d'accident grave ou même fatal.

CETTE SECTION CONTIENT DES INFORMATIONS GÉNÉRALES POUR SE PROTÉGER CONTRE LES DÉCHARGES ÉLECTRIQUES, LES INCENDIES, L'EXPOSITION EXCESSIVE AUX RAYONS UV ET TOUT AUTRE ACCIDENT POUVANT ENTRAÎNER DES BLESSURES.

AVERTISSEMENT:

DIRECTIVES POUR SE PROTÉGER CONTRE LES INCENDIES

1. Les luminaires VARI*LITE® ont été conçus pour être utilisés uniquement avec certaines lampes Philips et Osram HID. Vérifier le type de lampe (MSR400, MSR575HR etc.) avant de remplacer les lampes. L'installation d'un autre type de lampe peut poser un danger.
2. Les luminaires peuvent être fixés sur tout type de surface tant que les directives de montage sont respectées. Voir les explications détaillées dans ce guide.
3. Ne remplacer les fusibles qu'avec ceux du même type, ayant les mêmes caractéristiques.
4. Vérifier la distance à respecter entre les matériaux combustibles ou les objets illuminés et les luminaires VARI*LITE®.

AVERTISSEMENT:

DIRECTIVES POUR SE PROTÉGER CONTRE LES DÉCHARGES ÉLECTRIQUES

1. Les luminaires VARI*LITE® sont conçus pour une utilisation au sec uniquement. Une exposition à la pluie et à l'humidité risque d'endommager le luminaire.
2. Débrancher l'appareil avant de procéder à la révision de tout matériel VARI*LITE®.
3. Les révisions doivent être effectuées uniquement par des personnes qualifiées.

AVERTISSEMENT:

DIRECTIVES POUR SE PROTÉGER CONTRE UNE EXPOSITION EXCESSIVE AUX RAYONS UV

1. Plusieurs luminaires VARI*LITE® utilisent une lampe de type HID qui produit des rayons UV. NE PAS fixer son regard sur la lampe.
2. L'utilisation des luminaires sans lentille ou blindage pose des risques. Tous blindages, lentilles ou écrans ultraviolet visiblement endommagés au point que leur efficacité en est affectée doivent être remplacés, par exemple s'il y a des fissures ou de profondes rayures.

AVERTISSEMENT:

DIRECTIVES POUR SE PROTÉGER CONTRE LES ACCIDENTS POUVANT ENTRAÎNER DES BLESSURES

1. Les surfaces externes du luminaire deviennent brûlantes quand l'appareil est en marche. Pour manœuvrer ou ajuster des appareils brûlants et leurs composants, se protéger suffisamment (gants, protection pour les yeux, etc.).
2. La lampe du luminaire est brûlante lorsqu'il est en marche. Débrancher le courant et attendre que la lampe ait refroidi avant de la remplacer.
3. Les lampes à arc émettent des rayons ultraviolets pouvant causer de graves brûlures sur la peau et une inflammation des yeux. De plus, les lampes à arc fonctionnent sous haute tension à de très hautes températures. Si la lampe se casse, les particules de la lampe cassée peuvent causer blessures et/ou incendie en s'éparpillant.
4. Se protéger les yeux pour remplacer la lampe.
5. Utiliser des appareils de protection appropriés (gants, protection des yeux) pour manier des lampes endommagées.
6. Si la lampe a été touchée avec des mains nues, la nettoyer avec de l'alcool dénaturé et l'essuyer avec un chiffon non-pelucheux avant d'installer ou de brancher le luminaire.
7. Si la lampe a été endommagée ou a reçu une déformation thermique, elle doit être remplacée.

AVERTISSEMENT:

INTERFÉRENCE RF

1. Cet appareil est de Classe A. Dans un environnement domestique, cet appareil peut causer des interférences radio, et si c'est le cas, l'utilisateur peut avoir à prendre des mesures adéquates.

CONSIDÉRATIONS DES CARACTÉRISTIQUES DE LAMPES À ARC

1. Après une interruption de courant ou une baisse importante de voltage, les lampes à arc mettent du temps avant de se rallumer. Dans certains cas, la lampe se rallumera automatiquement après s'être refroidie. Cela dépend de la manière dont le système est réglé pour le statut de mise en marche de la lampe (L ON/ LOFF).
2. La position Brûler est Universelle.

Aviso sobre Seguridad

Es muy importante leer **TODA** la información e instrucciones sobre seguridad que se indica en este manual así como en los documentos adjuntos antes de instalar y operar los productos descritos. Se debe prestar atención a todos los avisos y advertencias durante la instalación y uso de este producto.

Los símbolos de seguridad usados en este manual son los siguientes:



CUIDADO, indica posibles daños al producto.



ADVERTENCIA, indica posibles lesiones o muerte a las personas.

LA INFORMACIÓN GENERAL RELACIONADA A LA PROTECCIÓN CONTRA GOLPES DE CORRIENTE ELÉCTRICA, INCENDIO, EXPOSICIÓN EXCESIVA A RADIACIÓN ULTRA VIOLETA Y LESIONES A LAS PERSONAS SE PUEDE ENCONTRAR SEGUIDAMENTE:

ADVERTENCIA:

INSTRUCCIONES PARA PROTECCIÓN CONTINUA CONTRA INCENDIO

1. Las luminarias VARI*LITE® han sido diseñadas para ser usadas solamente con algunas lámparas HID Philips y Osram. Tome nota del tipo de lámpara (MSR400, MSR575HR etc.) antes de reemplazarla. Instalación de otro tipo de lámpara puede ser peligroso.
2. Las luminarias se pueden instalar en cualquier tipo de superficie siempre que se sigan las instrucciones de instalación. Vea las instrucciones detalladas en este manual.
3. Reemplace los fusibles solamente con los del mismo tipo y especificación.
4. Tome nota de los requerimientos de distancia de materiales combustibles u objetos iluminados para las luminarias VARI*LITE®.

ADVERTENCIA:

INSTRUCCIONES PARA PROTECCIÓN CONTINUA CONTRA CHOQUE ELÉCTRICO

1. Las luminarias VARI*LITE® están diseñadas solamente para lugares secos. La exposición a la lluvia o humedad pueden dañar la luminaria.
2. Desconecte la energía antes de dar servicio a cualquier equipo de VARI*LITE®.
3. El servicio debe ser realizado solamente por personal calificado.

ADVERTENCIA:

INSTRUCCIONES PARA PROTECCIÓN CONTINUA CONTRA LA EXPOSICIÓN EXCESIVA DE RADIACIÓN ULTRA VIOLETA

1. Muchas luminarias VARI*LITE® usan un tipo de lámpara HID que produce radiación UV. NO mire directamente a la lámpara.
2. Es peligroso operar luminarias sin lentes o protectores. Debe cambiar los protectores, lentes o pantallas ultravioletas si se aprecia que han sido dañadas, y que su efectividad pudiera estar deteriorada. Por ejemplo, si tuvieran rajaduras o raspaduras profundas.

ADVERTENCIA:

INSTRUCCIONES PARA PROTECCIÓN CONTRA LESIONES DE PERSONAS

1. Las superficies exteriores de las luminarias están calientes durante su operación. Use un equipo de seguridad apropiado (guantes, protección para los ojos, etc.) cuando haga ajustes en el equipo y componentes que están calientes.
2. Cuando las luminarias están en operación la lámpara estará muy caliente. Desconecte la energía y deje que la lámpara se enfríe antes de reemplazarla.
3. Las lámparas de arco emiten radiaciones ultravioletas que pueden ocasionar serias quemaduras a la piel e inflamación a los ojos. Además, las lámparas de arco operan a alta presión y muy alta temperatura. Si la lámpara se rompe, puede existir el peligro de lesiones al personal o un incendio ocasionado por las partículas de la lámpara rota que se caen.
4. Use protección para los ojos cuando vuelve a colocar una lámpara nueva.
5. Use un equipo de seguridad apropiado (guantes, protección para los ojos, etc.) cuando trabaje con lámparas dañadas.
6. Si toca la lámpara con las manos, limpie la lámpara con alcohol desnaturalizado y con tela sin pelusas antes de instalar o volver a conectar la luminaria.
7. Cambie la lámpara si está dañada o deformada termicamente.

ADVERTENCIA:

INTERFERENCIA RF

1. Este es un producto de Clase A. En el ambiente de la casa este producto puede ocasionar radiointerferencia, en cuyo caso, el usuario debe tomar las medidas adecuadas.

CONSIDERACIONES SOBRE LAS CARACTERÍSTICAS DE LA LÁMPARA DE ARCO

1. Las lámparas de arco requieren un período de tiempo para volver a iluminarse después de una interrupción de energía o de una severa caída de voltaje. En algunos casos, la lámpara se volverá a iluminar en forma automática después que se ha enfriado dependiendo de la configuración del sistema de energía de la lámpara (L ON / L OFF) (L encendida / L apagada).
2. La posición de encendido es universal.

安全性に関する注意事項

ここに記載されている製品を取り扱う場合は、まず本マニュアルおよび付属のマニュアルの安全性に関する情報と説明をすべてお読みください。また、実際に本製品を取り付けたり使用する際には、すべての注意事項および警告に留意して作業してください。

本マニュアルでは、以下の安全マークを使用しています。



注意：製品に損傷を与える危険性があります。



警告：人身事故につながる危険性があります。

感電、火災、UV放射に対する過度の露出、および人身事故を防ぐための一般的な情報については、以下の説明をお読みください。

警告：

火災の発生を防ぐためのヒント

1. VARI*LITE® 照明器具は、ランプを使用するように設計されています。ランプを交換する際は、ランプの種類（など）を確認するようにしてください。他の種類のランプを取り付けると危険です。
2. 照明器具は、本マニュアルの指示に従って操作するかぎり、どのようなタイプの表面にでも取り付けることができます。詳細については、本マニュアルを参照してください。
3. ヒューズを交換する場合は、同じヒューズ（同じ種類、同じクラス）を使用してください。
4. VARI*LITE® 照明器具は、可燃性物質または他の光源から必要な距離だけ離して配置してください。

警告：

感電を防ぐためのヒント

1. VARI*LITE® 照明器具は、乾燥した環境で使用するように設計されています。雨で濡れる場所や湿気が多い場所に取り付けると、照明器具が傷むことがあります。
2. VARI*LITE® 照明器具を修理点検する場合は、必ず先に電源を切ってください。
3. 照明器具の修理点検は、資格を持つ技師のみが行うようにしてください。

警告：

過度の UV 放射にさらされないためのヒント

1. VARI*LITE® 照明器具の多くは、UV 放射を生ずる HID タイプのランプを使用しています。ランプを直視することは避けてください。
2. レンズまたはシールドを使わずに照明器具を点灯すると危険です。レンズ、シールド、紫外線画面は、ひび割れや深い引っかき傷などにより、その効力が損なわれるようになったら取り替えるようにします。

警告：

人身事故を防ぐためのヒント

1. 照明器具が点灯しているときは、その外側が熱くなります。熱くなった器具やコンポーネントを取り扱う際には、適切な防具（手袋や保護用眼鏡）を使用してください。
2. 照明器具が点灯しているときは、そのランプが熱くなります。ランプを交換する場合は、照明器具の電源を切り、ランプの温度が下がるまで待ってください。ランプの裏ぶたをあけると、遮断スイッチが働いて、ランプの電源が切れる場合があります。
3. アーク灯は紫外線を放射します。この紫外線によって、ひどい火傷を負ったり、目の炎症を起こすことがあります。さらに、アーク灯は、高圧高温の状態で光を発します。そのため、万一アーク灯が破損すると、飛び散った破片で人身事故や火災が発生する危険性があります。
4. 再点灯するときには、保護用眼鏡を着用してください。
5. 損傷したランプを取り扱う場合は、適切な防具（手袋や保護用眼鏡）を着用してください。
6. 手袋を着用せずに直接手でランプを触った場合は、変性アルコールを使ってランプをきれいにし、糸くずの出ない布で拭いてから照明器具を取り付け、電源を入れるようにします。
7. 傷がついたランプや熱によって変形したランプは取り替えてください。

警告：

RF 干渉

1. 本製品は Class A に分類されます。本製品は、家庭環境において無線干渉を起こす可能性があります。その場合、使用者は適切な処置を取らなければならないことがあります。

アーク灯の特性

1. 停電後または大きな電圧ディップ後にアーク灯を再点灯する場合は、しばらく時間をおくようにしてください。Lamp Power-Up State) システム設定によっては、温度が下がったときに自動的に再点灯される場合もあります。
2. アーク灯は点光源です。

Table of Contents

Introduction

Disclosure	1
About This Manual	1
Additional Documentation.....	2
Customer Service	2

Chapter 1. Description

Features

Standard Features	4
Model Specific Features	4

Component Descriptions

External Luminaire Components	6
Luminaire Internal Head Components	7
Luminaire Internal Yoke Components	8
Arc Ballast Unit	9
Dimmer Model.....	9

Principles of Operation

VL1000 Incandescent Source Luminaire.....	10
VL1000 Incandescent Block Diagram - Without On-Board IGBT Dimmer	10
VL1000 Incandescent Cable Routing - Without On-Board IGBT Dimmer	11
VL1000 Incandescent Block Diagram - With On-Board IGBT Dimmer	12
VL1000 Incandescent Cable Routing - With On-Board IGBT Dimmer.....	13
VL1000 Arc Source Luminaire	14
VL1000 Arc Block Diagram	14
VL1000 Arc Cable Routing	15

Chapter 2. Maintenance

Testing

Running Parameter Tests	18
-------------------------------	----

Maintenance Procedures

Lamp Replacement (Incandescent Model)	20
Lamp Replacement (Arc Model)	22
Align Lamp For Maximum Beam Irradiance	24
Frame or Top Hat Replacement	25
Front Cover Removal.....	26
Rear Head Assembly Removal	27
Rotating Gobo Replacement	28
Gobo Index Timing Belt Alignment	30
Gobo Wheel Bulkhead Replacement.....	32
Gobo Gear Planet Alignment.....	34

Shutter Assembly Replacement.....	36
Shutter Blade or Rack Replacement.....	38
Edge/Zoom/Color Bulkhead Replacement.....	40
Fan/Temp Switch Assembly Replacement.....	41
Beam-Size Iris Assembly Replacement	42
Ignitor PCB Replacement.....	43
Power Supply Replacement.....	44
Controller PCB Replacement	46
Tilt Encoder PCB Replacement.....	48
Tilt Motor Assembly Replacement.....	49
.....	50
Pan Motor Assembly Replacement	51
DMX Input PCB Replacement.....	53
Cleaning Optical Lenses and Filters.....	54

Chapter 3. Illustrated Parts Breakdown

Drawing Trees

VL1000 Incandescent Luminaires.....	56
VL1000 Arc Luminaires.....	58

Top Assembly

Included Items Kit.....	60
Included Items Kit (continued).....	61
Label Locations	62
VL1000 Luminaire	64
Front Cover Assembly	67
Gel Frame Holder Assembly	68
COT (Center of Travel) Flag Assembly	69

Head Assembly

Head Assembly	71
Front Head Assembly	72
Edge Control, Zoom, Dimmer & Color Assembly	74
Color Changer Assembly	76
Cover Plate Assembly	79
Edge Barrel Assembly	80
Lens #6 Assembly	82
Lens #7 Assembly	83
Lens #8 Assembly	84
Fan Assembly	85
Pulley Side Rail Assembly	86
Sensor Side Rail Assembly	87
Incandescent Gobo Wheel Assembly	88
Temperature Sensor Electrical Assembly	91
Arc Gobo/Dimmer Bulkhead Assembly	92
Gobo Wheel Assembly	95
Shutter 6 Rollers Assembly	97
Beam-Size Iris Assembly	100

Rear Head Assembly	102
Back Cap Assembly	104
Yoke Assembly	
Yoke Legs Assembly	107
Tilt Motor Assembly	110
Crossmember Assembly	112
Inner Crossmember Assembly	114
Outer Crossmember Assembly	115
Pan Motor Assembly	116
Pan Tube Assembly	118
DMX Input PCB Assembly	120
Cables	
Arc Power Input (Pigtail) Cable Assembly	121
Pan EOT Cable Assembly	123
Tilt COT Cable Assembly	124
AC Line Input Cable Assembly	125
Incandescent LVS AC Input Cable Assembly	126
Arc LVS AC Input Cable Assembly	127
LVS Chassis Ground Cable Assembly	128
Head to Backcap Ground Cable Assembly	129
Yoke to Head Ground Cable Assembly	130
Pan/Tilt Control Cable Assembly	131
Ballast Control Link Cable Assembly	133
Data I/O Link Cable Assembly	134
LVS DC Output Cable Assembly	135
Incandescent Power Input Cable Assembly	136
Incandescent Lamp Power Cable Assembly	137
Arc Power to Ignitor Cable Assembly	138
Ignitor to Lamp Socket Cable Assembly	139
Shutter Harness Cable Assembly	140
Color/Gobo/Lens Harness Cable Assembly	142
Dimmer to LVS Cable Assembly	145
Dimmer to Controller Cable Assembly	146
Dimmer to Lamp Socket Cable Assembly	147
575W Ballast I/O Cable Assembly	148

Appendix A. Technical Bulletins

VL1000™ ERS Luminaire Technical Bulletins	151
---	-----

(This page intentionally blank.)

Introduction

Disclosure

This technical manual is confidential property of Vari-Lite. All information contained herein is the sole and exclusive property of Vari-Lite and may not be used, disclosed, or reproduced in any manner without the prior written consent of Vari-Lite.



WARNING: It is important to read ALL accompanying safety instructions to avoid damage to the product and potential injury to yourself or others.

About This Manual

This manual provides descriptions, repair procedures, and illustrated parts breakdowns for all configurations of the VL1000™ ERS Luminaire. The manual is intended for use by Vari-Lite personnel and by Vari-Lite's Authorized Dealers and Service Centers.

This manual covers the following models:

Model	Part Number	Source	Dimmer	Shutter	Iris
VL1000 TS	20.9663.0001.02	Incandescent	-	X	
VL1000 TI	20.9663.0001.03	Incandescent	-		X
VL1000 AS	20.9663.0001.12	Arc	-	X	
VL1000 AI	20.9663.0001.13	Arc	-		X
VL1000 TSD	20.9663.0001.22	Incandescent	115V	X	
VL1000 TID	20.9663.0001.23	Incandescent	115V		X
VL1000 TSE	20.9663.0001.32	Incandescent	240V	X	
VL1000 TIE	20.9663.0001.33	Incandescent	240V		X



Note: Performing maintenance procedures contained in this manual may void the product warranty. Refer to the Vari-Lite Limited Warranty card included in the shipping package for this VARI*LITE® product.



WARNING: It is not recommended to power any VARI*LITE® luminaire from a dimmer - even in 'NONDIM' mode. Dimmer and non-dim modules are not suitable sources of power because their output modifies the AC wave form. See Vari-Lite Technical Notice TN-229A for more information.

Additional Documentation

A support webpage for Series 1000 luminaires is available at www.vari-lite.com (follow the Support link).

A user's manual is available for installation and operation of all versions of the VL1000™ ERS Luminaire. This manual is only available in electronic (PDF) format.

- VL1000™ ERS Luminaire User's Manual (02.9663.0001).

Technical bulletins concerning the latest changes to VARI*LITE® equipment are also available at the website Technical Support Center. These are documentation supplements that contain procedures for equipment upgrades, retrofits, and additional repairs. Technical bulletins are integrated into the appropriate equipment manuals as those manuals are revised.

Customer Service

Our Goal

At Vari-Lite, we are committed to providing you the highest quality in customer service. Our comprehensive resources are available to help your business succeed and ensure you get the full benefit of being a Vari-Lite customer. Whether your needs are telephone troubleshooting assistance, product training or technical service, our full-time staff of experienced professionals are on-hand to provide support.

How to Reach Us

For assistance in your area, call the dealer from which your product(s) were purchased.

or

Contact an Authorized Service Center.

or

Contact the Vari-Lite Customer Service Department, 9am - 6pm CST Monday through Friday, at the following:

phone: 1-877-VARI-LITE (1-877-827-4548)

fax: 1-214-647-8038

email: customerservice@genlytecontrols.com

Additional Resources

For additional resources and documentation, please visit our website at: www.vari-lite.com and follow the Support link.

CHAPTER 1.

Description

This chapter provides an overview of luminaire features, components and operations.

- **Features**
- **Component Descriptions**
- **Principles of Operation**



Features

Standard Features

VL1000 Ellipsoidal Reflector Spotlight (ERS) luminaires have the following standard features:

- Automated zoom optics system.
- Crossfading CYM color system.
- Diffusion system.
- Six-position rotating gobo wheel (five rotatable, indexable gobo positions and one open gobo position).
- Repositional pan/tilt system.
- Control by DMX512 protocol.

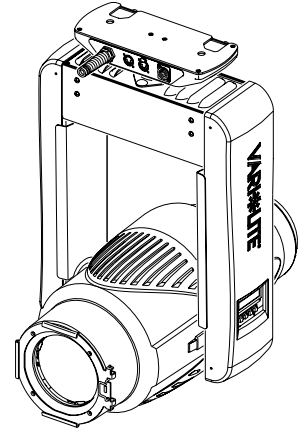

Model Specific Features

Each individual configuration has the following specific features:

VL1000 TS (20.9663.0001.02)

- 1000W Tungsten Halogen lamp source.
- Four-blade shutter framing system.

VL1000 TI Luminaire (20.9663.0001.03)

- 1000W Tungsten Halogen lamp source.
- Beam-size iris mechanism.

VL1000 AS (20.9663.0001.12)

- 575W arc lamp source with external ballast unit.
- Four-blade shutter framing system.

VL1000 AI (20.9663.0001.13)

- 575W arc lamp source with external ballast unit.
- Beam-size iris mechanism.

VL1000 TSD Luminaire (20.9663.0001.22)

- 1000W Tungsten Halogen lamp source.
- 115V on-board dimmer.
- Four-blade shutter framing system.

VL1000 TID Luminaire (20.9663.0001.23)

- 1000W Tungsten Halogen lamp source.
- 115V on-board dimmer.
- Beam-size iris mechanism.

VL1000 TSE Luminaire (20.9663.0001.32)

- 1000W Tungsten Halogen lamp source.
- 240V on-board dimmer.
- Four-blade shutter framing system.

VL1000 TIE Luminaire (20.9663.0001.33)

- 1000W Tungsten Halogen lamp source.
- 240V on-board dimmer.
- Beam-size iris mechanism.

Component Descriptions

External Luminaire Components

The following illustration shows the external luminaire components and controls.

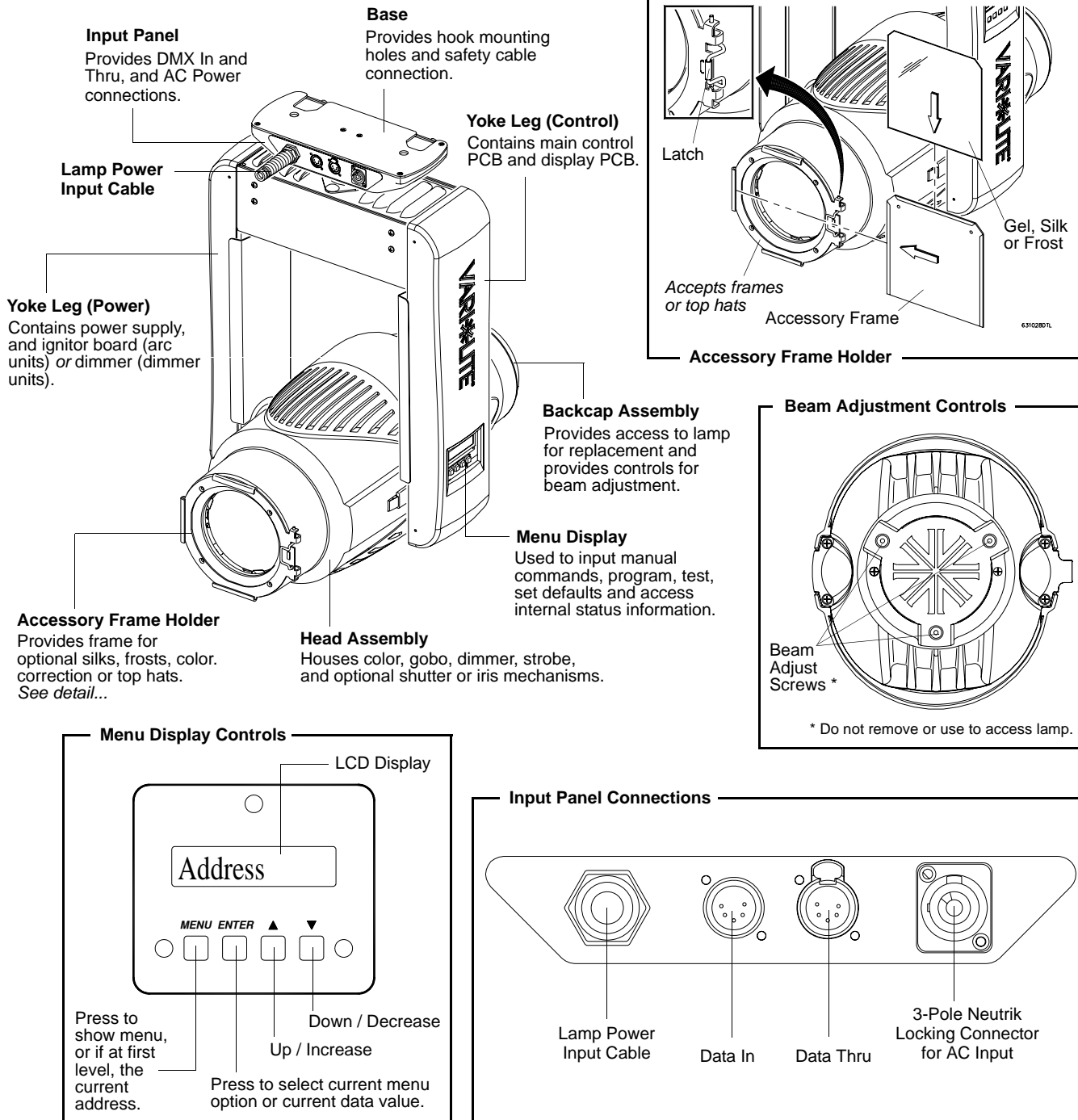

Luminaire Internal Head Components

The following illustration shows the major sub-assemblies that are located in the luminaire head assembly.

A options - Shutter or Beam-size Iris bulkhead is dependent on model.

B options - Rotating Gobo Bulkhead version is dependent on model.

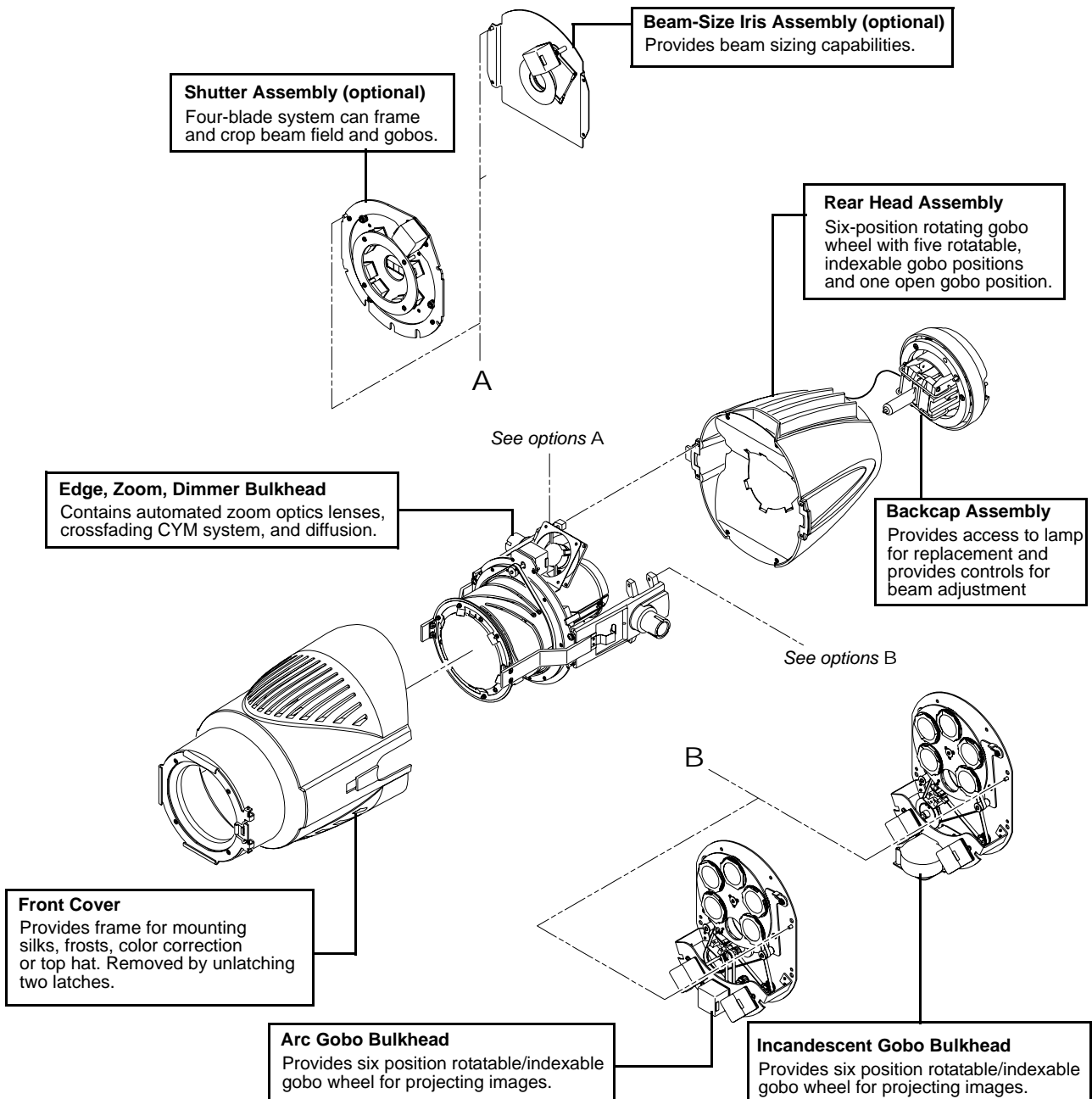

Luminaire Internal Yoke Components

The following illustration shows the major sub-assemblies that are located in the luminaire yoke assembly.

Note: Head assembly not shown for clarity.

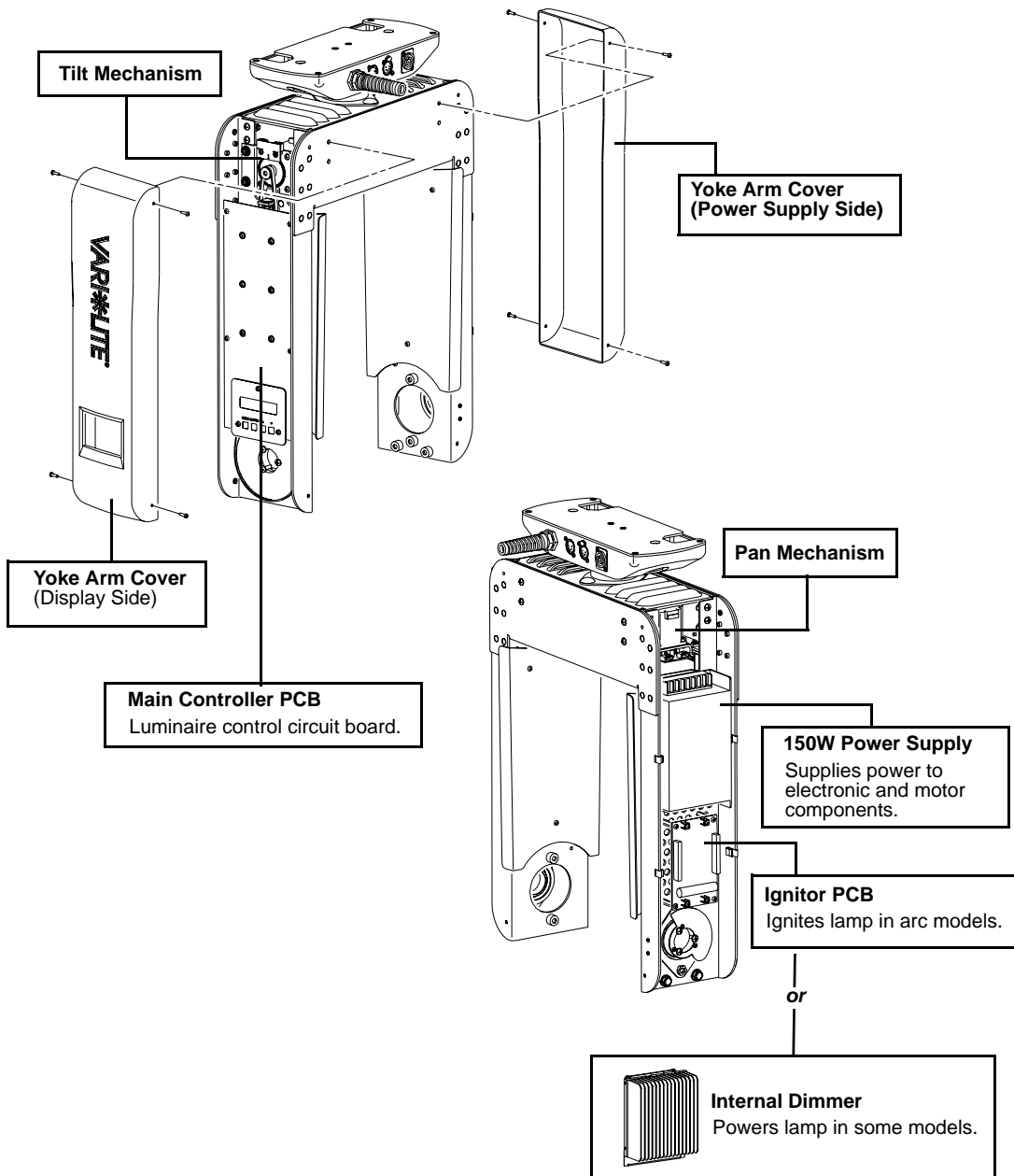

Arc Ballast Unit

An external ballast unit is included with VL1000 arc models. In this case, the lamp power input cable is already connectorized for use with this unit.

The following illustration shows the external arc ballast components.

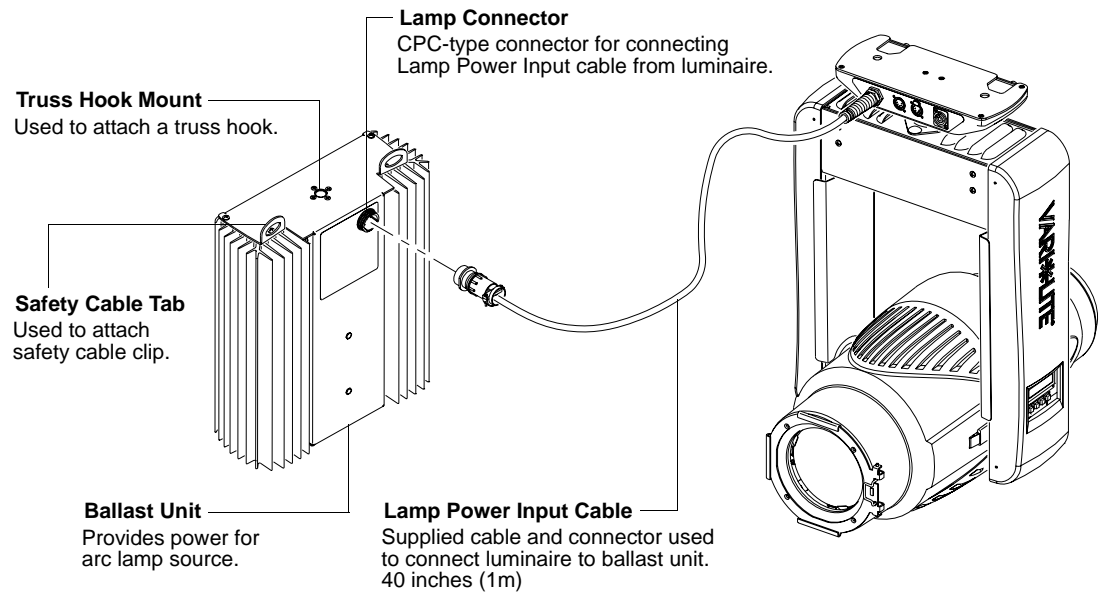

Note: The Lamp Power Input Cable has conductors for lamp power and ballast control. It is not compatible with VARI*LITE Series 300™ lamp runs.

Dimmer Model

An on-board IGBT dimmer is included with VL1000 incandescent dimmer models. The dimmer heatsink is visible on the power-side yoke leg as shown in this illustration.

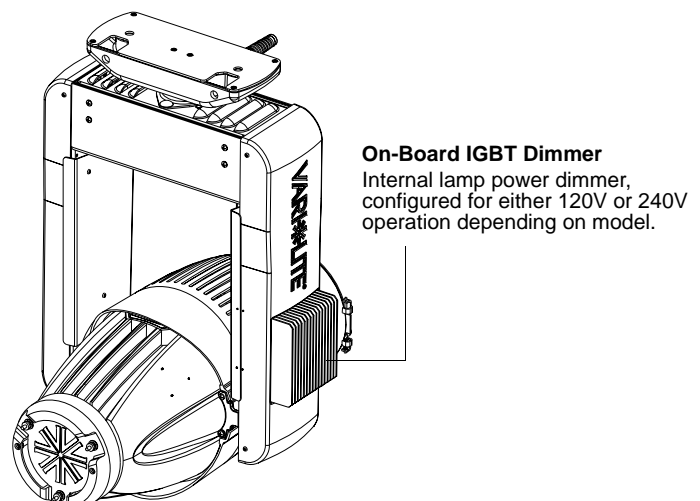

Principles of Operation

VL1000 Incandescent Source Luminaire

VL1000 Incandescent Block Diagram - Without On-Board IGBT Dimmer

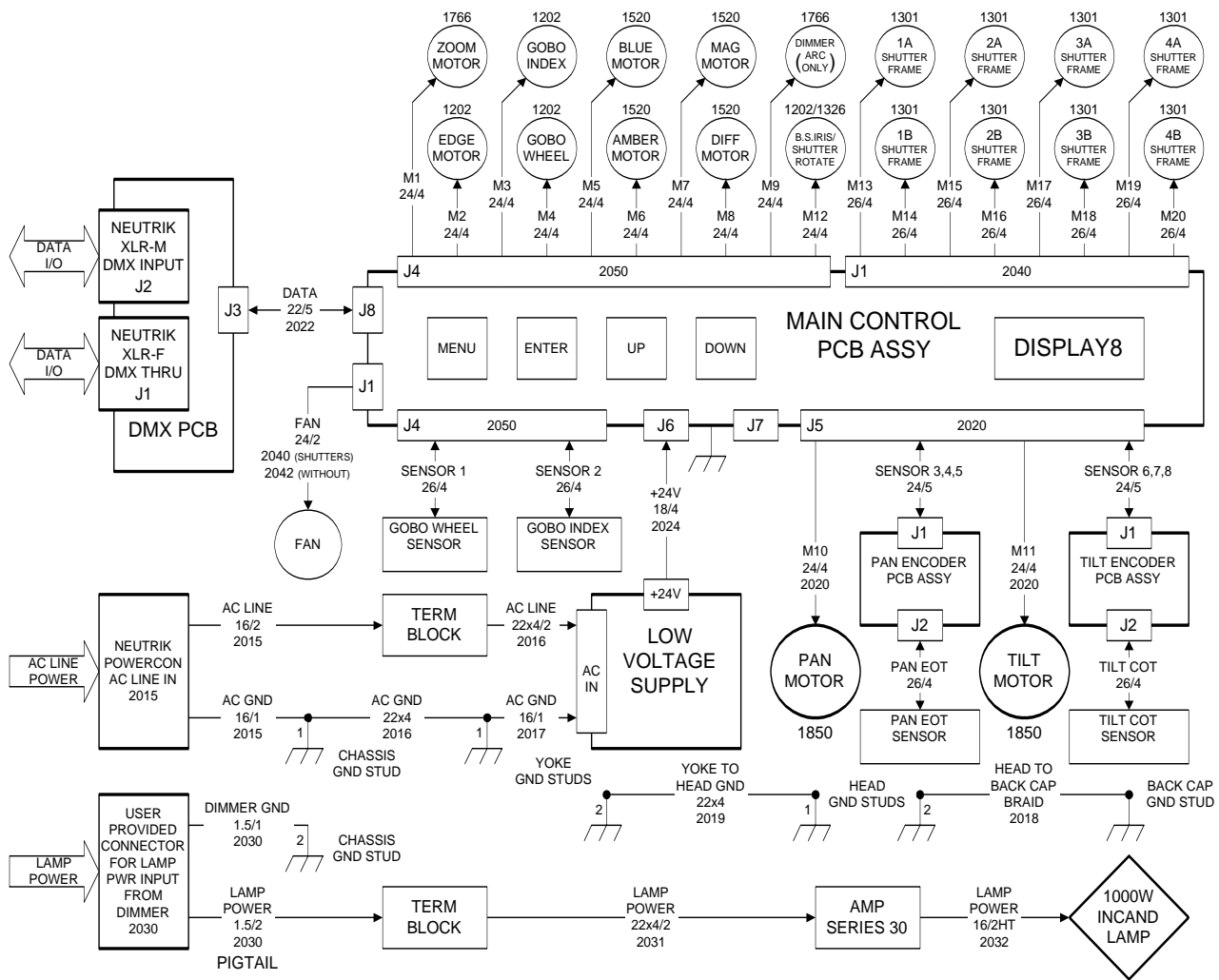

VL1000 Incandescent Cable Routing - Without On-Board IGBT Dimmer

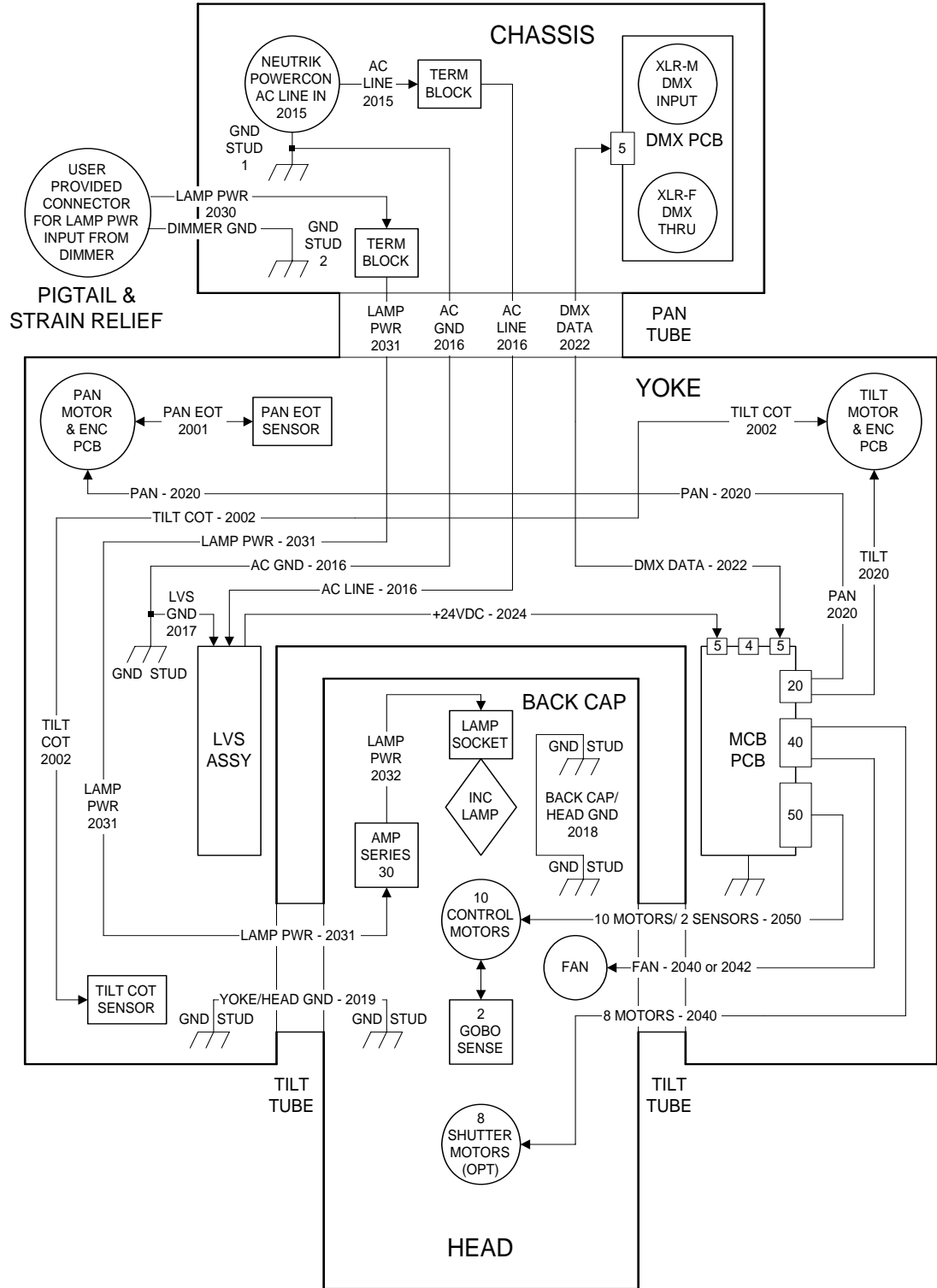

VL1000 Incandescent Block Diagram - With On-Board IGBT Dimmer

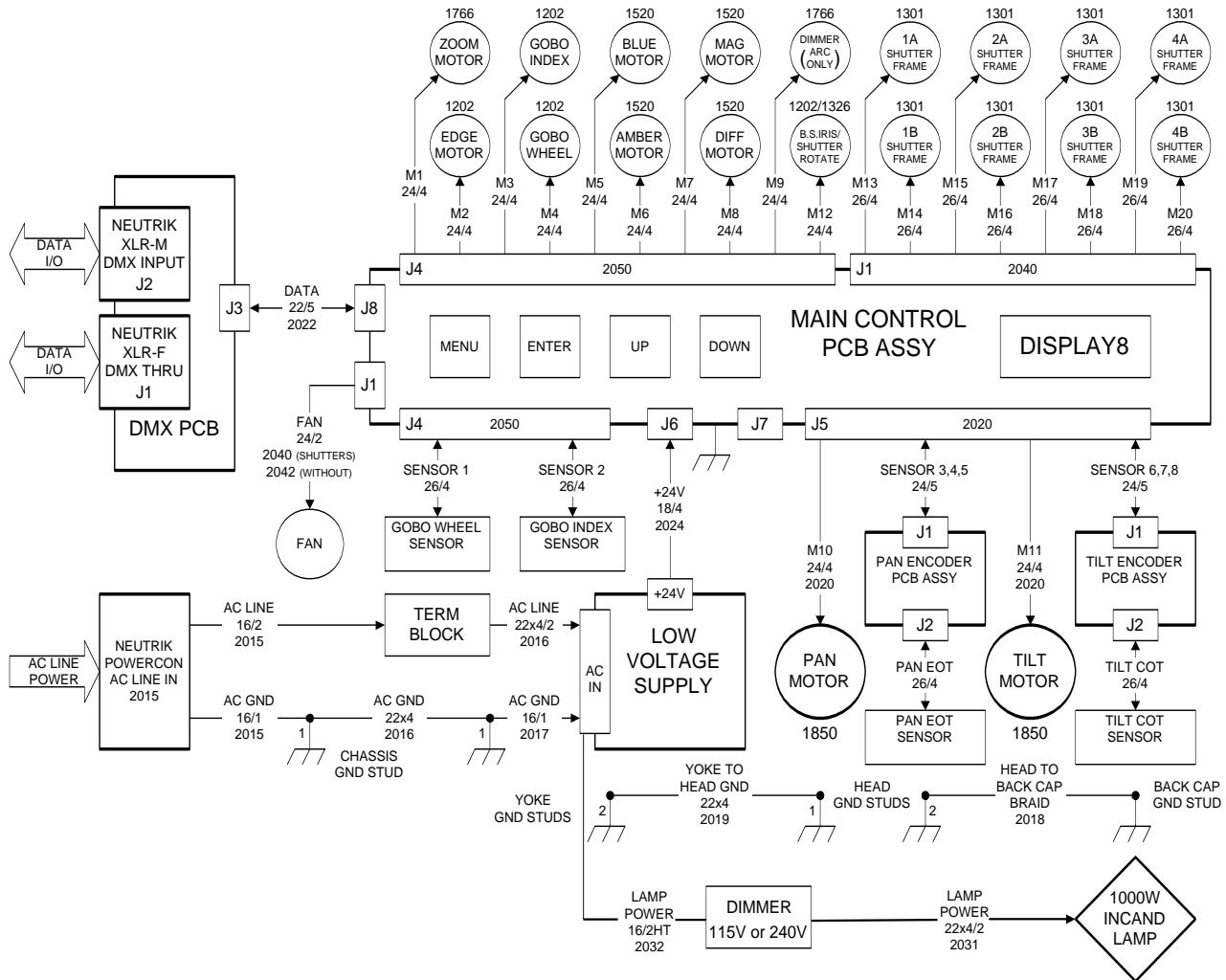

VL1000 Incandescent Cable Routing - With On-Board IGBT Dimmer

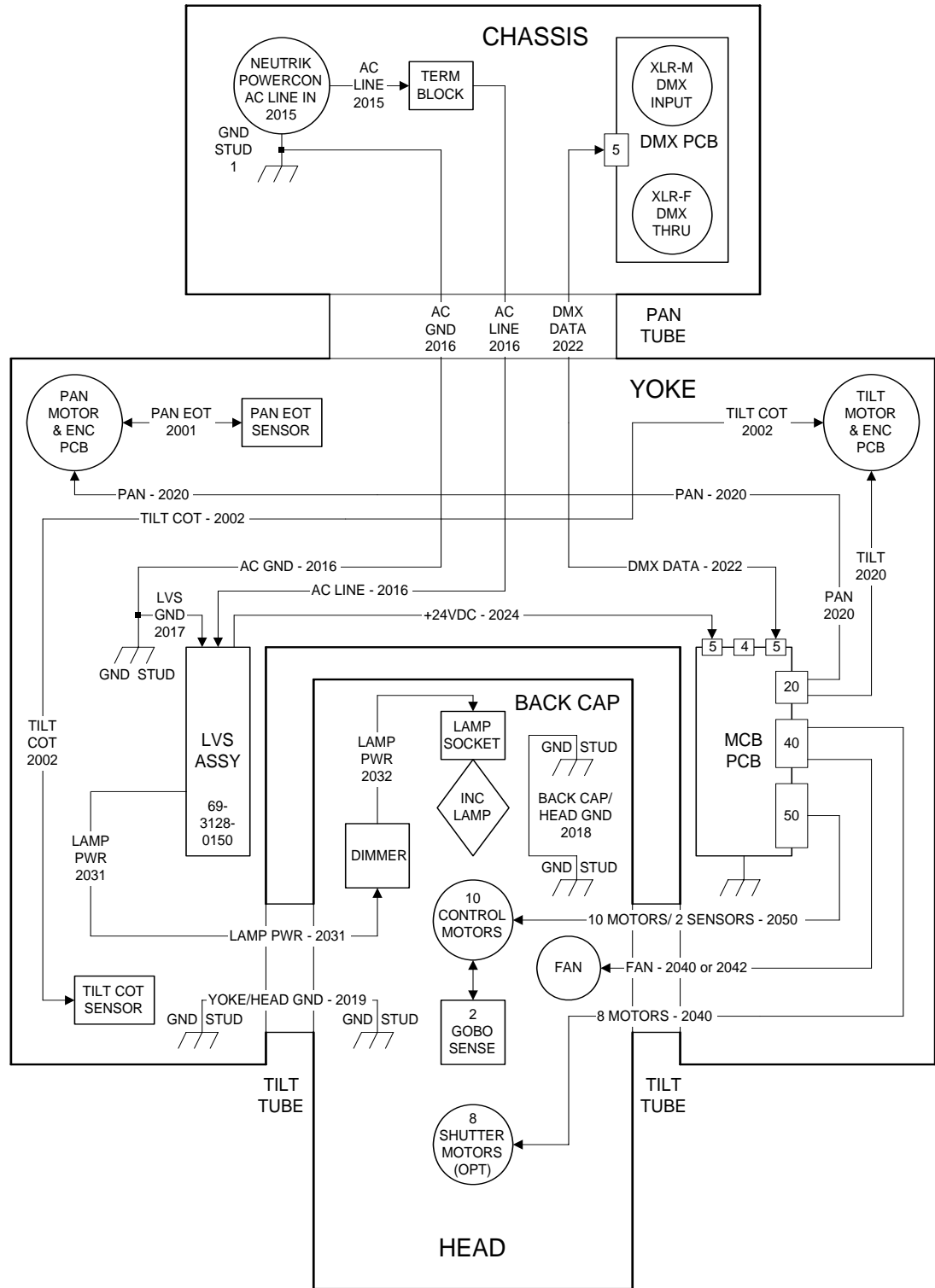

VL1000 Arc Source Luminaire

VL1000 Arc Block Diagram

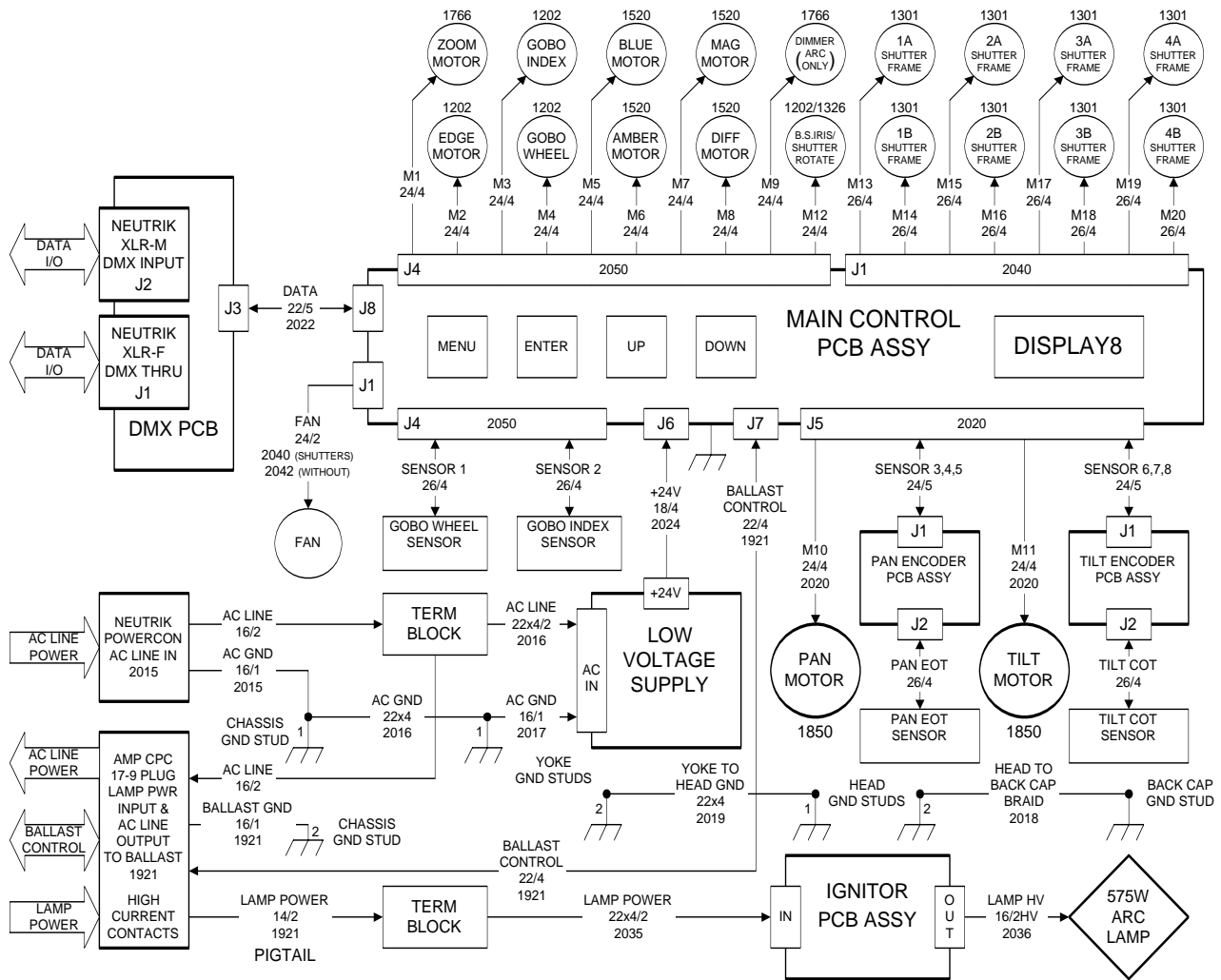

VL1000 Arc Cable Routing

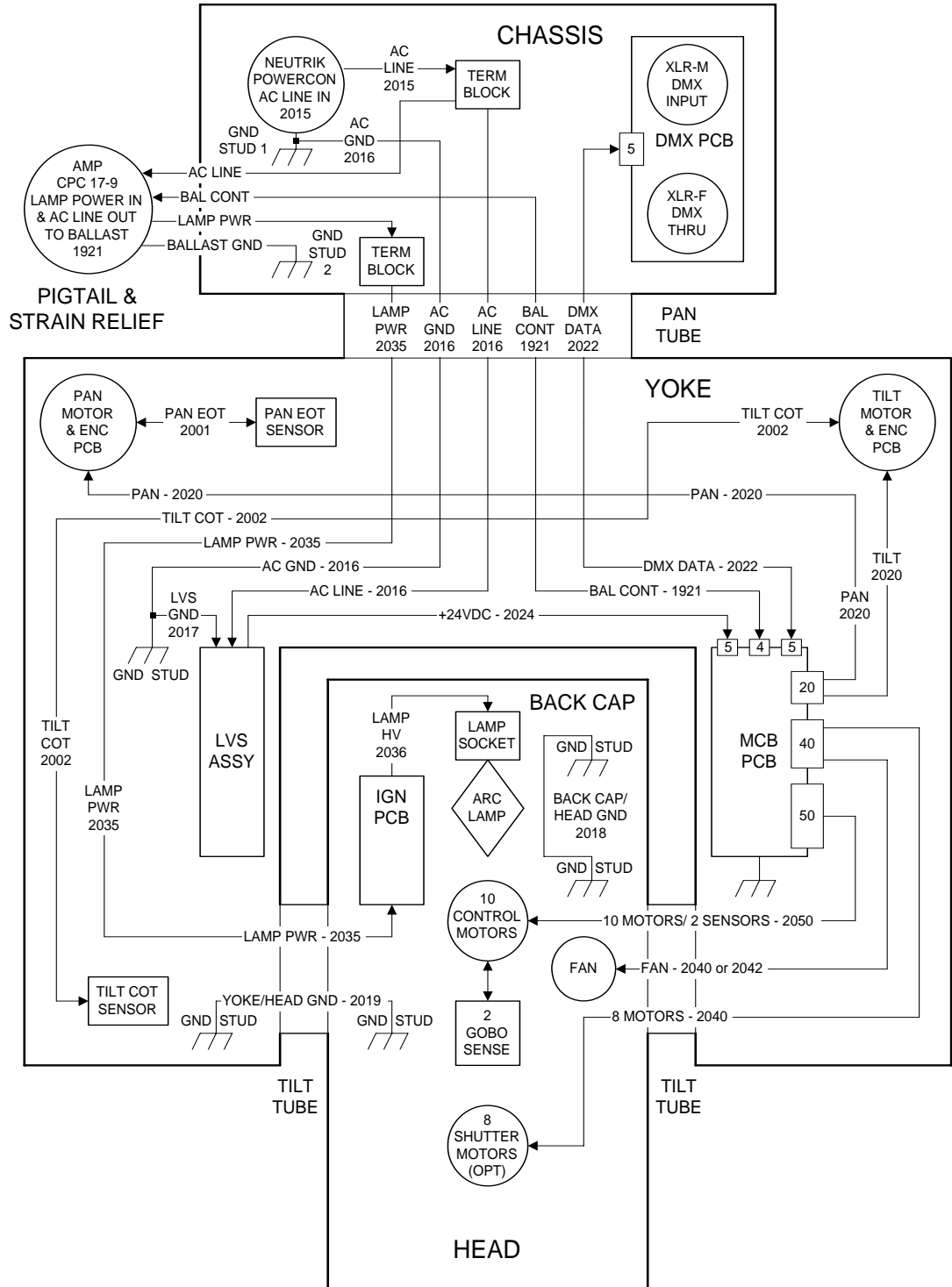

Notes

CHAPTER 2.

Maintenance

This chapter contains test, service, and standard maintenance procedures.

- **Testing**
- **Maintenance Procedures**



WARNING: All maintenance procedures are to be performed with power removed from the luminaire. Never remove cover or backcap while lamp is in operation.



Testing

Running Parameter Tests

The luminaire is capable of running self tests by using the **TEST** menu functions.

When running tests on multiple luminaires, a loopback connector is required at the master luminaire (first in link) and a male termination connector is required at the last luminaire in the link. Refer to the VL1000 ERS User's Manual for more information regarding these connectors.

Note: After 10 seconds of inactivity, the menu display will change to the default state showing the address.

To connect luminaires for simultaneous testing:

- Step 1. At first luminaire in link, install loopback connector into DATA IN XLR connector.
- Step 2. At last luminaire, install male termination connector into DATA THRU XLR connector.

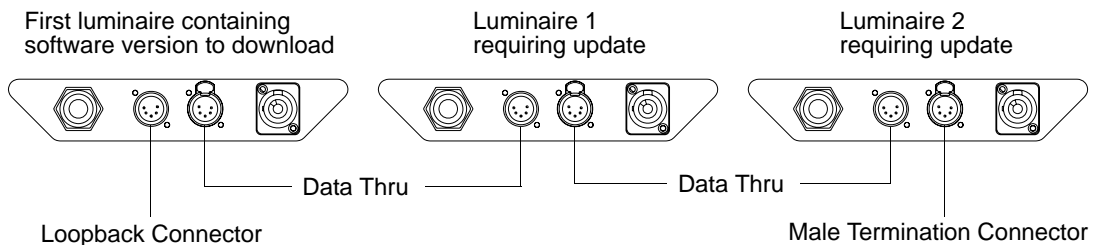

- Step 3. At master luminaire Menu Display, press [Menu].

Movement Disable

The **Movement** option has been added to the configuration menu. This allows for pan/tilt functions to be disabled so that the luminaire can be placed in any position for testing without movement occurring. In order to regain full control of the luminaire, **Movement** will need to be enabled after testing.

Note: When setting the **Movement** option to disable, luminaires linked by a loopback connector will have pan and tilt disabled for all the luminaires that are linked.



WARNING: Backcap and adjustment knobs will be HOT during lamp operation. Wear gloves and/or use tools to prevent burns.

To run tests:

- Step 1. Press [Menu].
- Step 2. Press [Up] / [Down] arrows until **Test** appears. Press [Enter].
- Step 3. Use [Up] / [Down] arrows to select a parameter to test. Refer to table below for a complete list of test parameters.
- Step 4. Press [Enter] to run test.
- Step 5. Press [Menu] to stop test at any time.

Table 2-1: Self Test Function Chart

1st Level	2nd Level	3rd Level	4th Level	5thLevel	
Test System Test	ALL Test All Motors	RUN TEST Run-Test in Progress	Press [Menu] to stop tests		
	Pan/Tilt	RUN TEST Run-Test in Progress			
	Dimmer (Arc Only)	RUN TEST Run-Test in Progress			
	Blue	RUN TEST Run-Test in Progress			
	Amber	RUN TEST Run-Test in Progress			
	Magenta	RUN TEST Run-Test in Progress			
	ColorMix Blue, Amber, Magenta test	RUN TEST Run-Test in Progress			
	Diffusn Diffusion Test	RUN TEST Run-Test in Progress			
	Rot Gobo Rotating Gobo Test	RUN TEST Run-Test in Progress			
	Edge	RUN TEST Run-Test in Progress			
	Zoom	RUN TEST Run-Test in Progress			
	Beam (If Beam-Size Iris Accessory)	RUN TEST Run-Test in Progress			
	Shutter (If Shutter Accessory)	RUN TEST Run-Test in Progress			
	Rot Shut (If Shutter Accessory)	RUN TEST Run-Test in Progress			
	Lamp Disables Pan/Tilt and executes Home position.	RUN TEST Run-Test in Progress			
	Encoder Encoders	Pan Pan Encoder		XXXX Data	
		Tilt Tilt Encoder		XXXX Data	
	Sensor Sensors	Pan COT Sensor		STST Sensor Test in Progress	PASS/FAIL
		Tilt COT Sensor		STST Sensor Test in Progress	PASS/FAIL
		Rot Gobo Gobo Select EOT Sensor		STST Sensor Test in Progress	PASS/FAIL
GoboIdx Gobo Index EOT Sensor			STST Sensor Test in Progress	PASS/FAIL	

Maintenance Procedures

Lamp Replacement (Incandescent Model)

Parts:

- 1000 WATT INCANDESCENT LAMP, 100 VAC (71.2552.0100) - TS/TI
- 1000 WATT INCANDESCENT LAMP, 115 VAC (71.2552.0115) - TS/TI
- 1000 WATT INCANDESCENT LAMP, 240 VAC (71.2554.0240) - TS/TI

Tools:

- #2 Phillips screwdriver, cotton gloves



CAUTION: Wear cotton gloves or other covering while installing lamp. Touching lamp glass with bare fingers will leave oil and may cause the lamp to explode or reduce lamp life. If touched, use alcohol and cotton cloth to thoroughly clean glass portion of lamp.

To install incandescent lamp:

- Step 1. Remove power from luminaire.
- Step 2. At backcap, gradually loosen two 10-32x2-3/8" PPSS black screws (Figure 2-1) a few turns at a time until backcap is free. (Screws must be alternately loosened to prevent one side from locking up.)

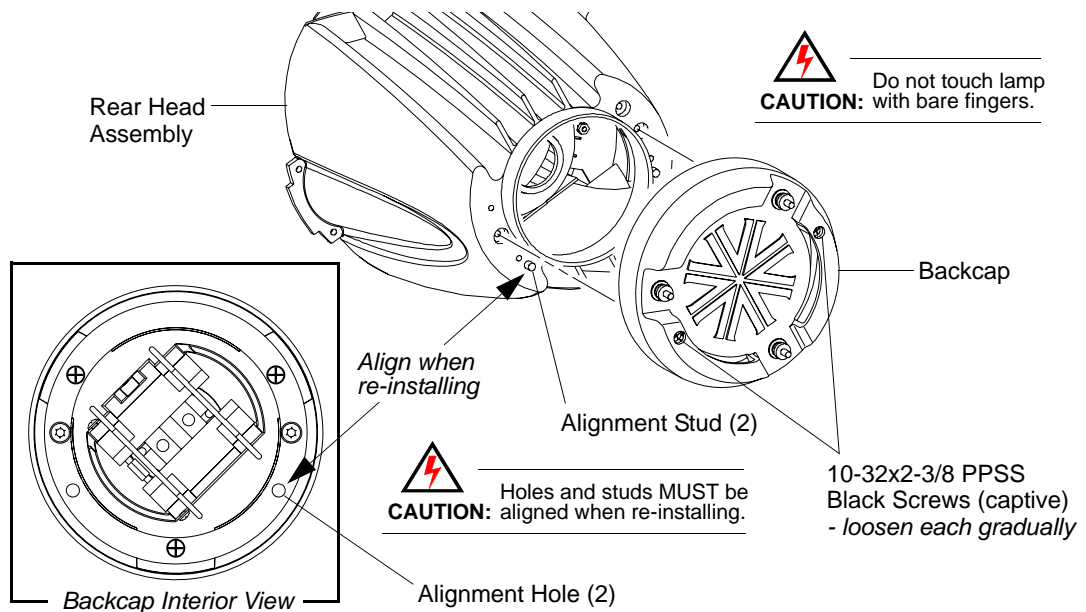



Figure 2-1: Removing Incandescent Backcap

- Step 3. Carefully pull backcap straight out of rear head assembly. (It will still be attached by lamp wires and tether.)
- Step 4. At backcap, flip two bail clamps outward (**Figure 2-2**).
- Step 5. Flip two base clamps outward away from socket.
- Step 6. Grip lamp by base and firmly install in socket.
- Step 7. Close base and bail clamps, locking into place.

 Do not touch lamp with bare fingers.
CAUTION:

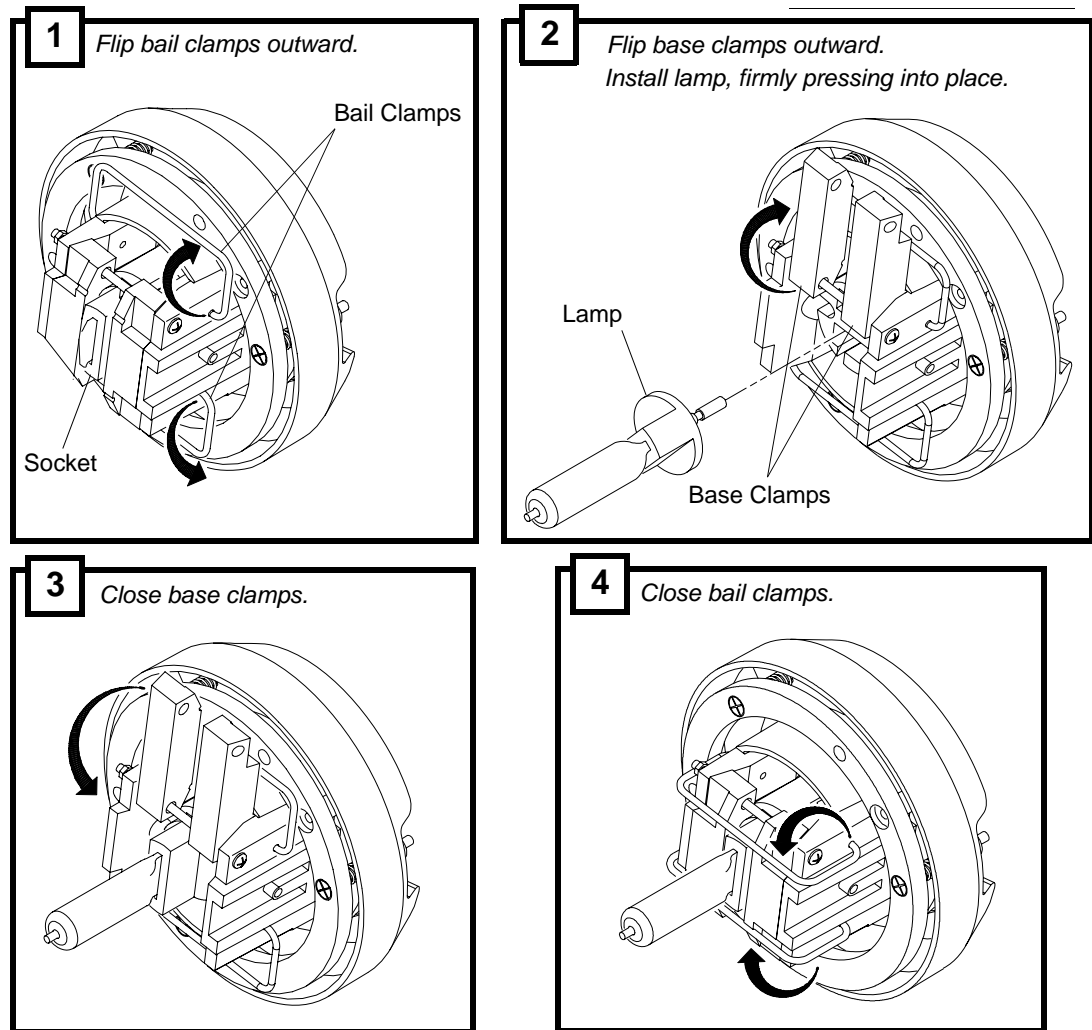

Figure 2-2: Installing Incandescent Lamp in Socket

- Step 8. Re-install backcap, ensuring that alignment studs and holes are aligned (**Figure 2-1**).
- Step 9. Align lamp. (Refer to “Align Lamp For Maximum Beam Irradiance” on page 24.)

Lamp Replacement (Arc Model)

Parts:

575 WATT ARC LAMP, MSR575HR (71.2528.0575) - AS/AI

Tools:

#2 Phillips screwdriver, cotton gloves



CAUTION: Wear cotton gloves or other covering while installing lamp. Touching lamp glass with bare fingers will leave oil and may cause the lamp to explode or reduce lamp life. If touched, use alcohol and cotton cloth to thoroughly clean glass portion of lamp.

To install arc lamp:

- Step 1. Remove power from luminaire.
- Step 2. At backcap, gradually loosen two 10-32x2-3/8" PPSS black screws (Figure 2-3) a few turns at a time until backcap is free. (Screws must be alternately loosened to prevent one side from locking up.)

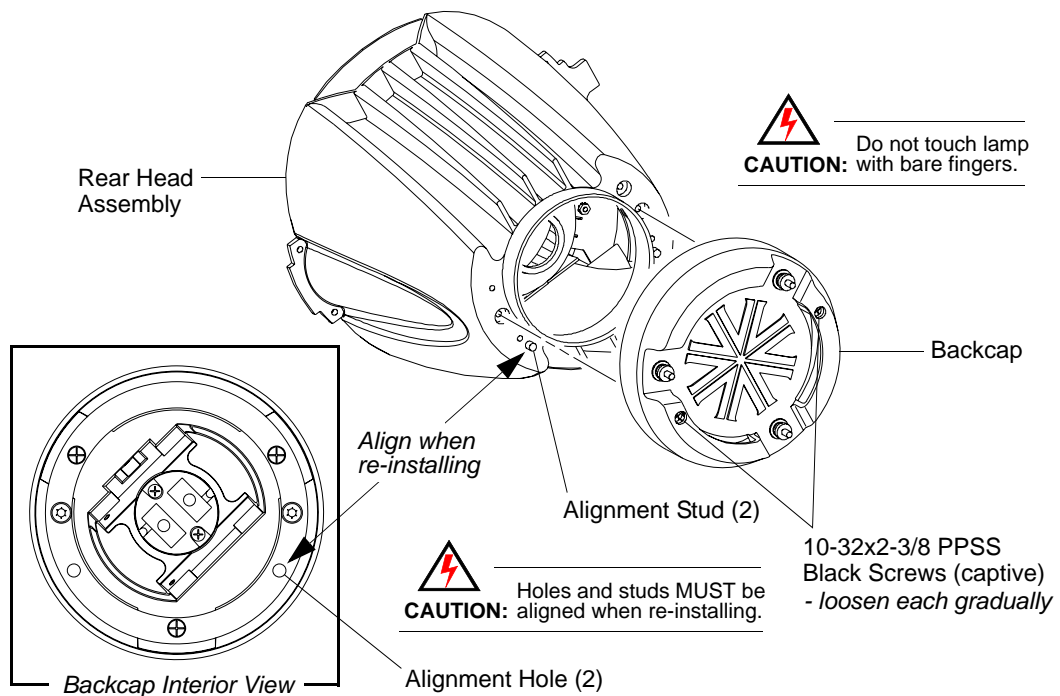

Figure 2-3: Removing Arc Backcap

Step 3. Grip lamp by base and firmly install in socket (**Figure 2-4**).

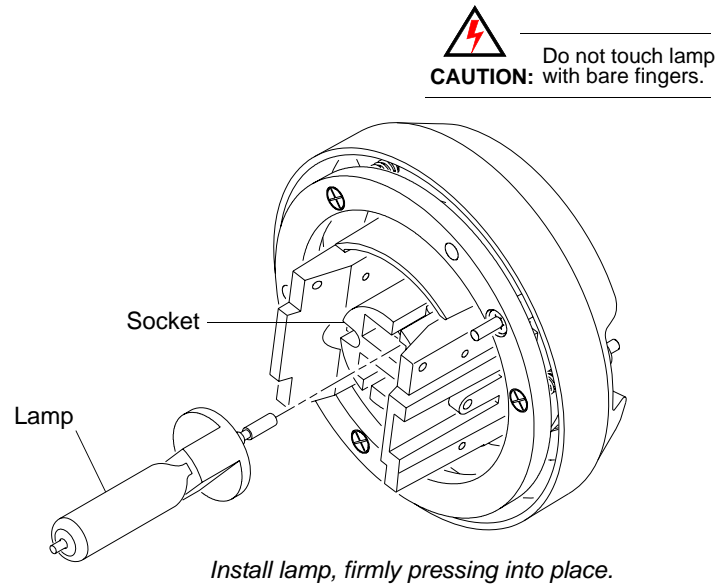

Figure 2-4: Installing Arc Lamp in Socket

- Step 4. Re-install backcap, ensuring that alignment studs and holes are aligned (**Figure 2-3**).
- Step 5. Align lamp. (Refer to “[Align Lamp For Maximum Beam Irradiance](#)” on [page 24](#).)

Align Lamp For Maximum Beam Irradiance

After a new lamp is installed in either the incandescent or arc version of the luminaire, it will be necessary to align the lamp to optimize the beam.

Tools:

#2 Phillips screwdriver



WARNING: Backcap and adjustment screws will be HOT during lamp operation. Wear gloves and/or use tools to prevent burns.

To align lamp:

- Step 1. Set intensity to 100%.
- Step 2. Position beam on a white wall at a distance of 10 to 20 feet.
- Step 3. Using console or internal luminaire menu controls, set zoom to zero and focus to a hard edge. If installed, be sure that beam-size iris and shutters are open.
- Step 4. Using three adjustment screws, adjust hot spot to center of beam ([Figure 2-5](#)).
- Step 5. Check color uniformity as follows:
- Position one of the color stages at 30% of maximum. (Cyan or Magenta work best.)
 - Verify that beam color is uniform (if lamp is misaligned, color will be concentrated to one side of beam). If color is not uniform, readjust lamp until color is uniform across entire beam field.

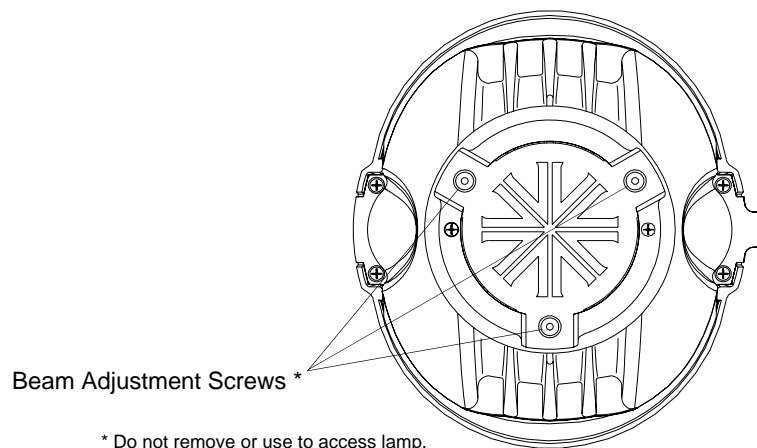

Figure 2-5: Lamp Alignment Screws

Frame or Top Hat Replacement

An accessory frame holder is provided for the addition of a top hat or gel frame with silks, frosts or color correction if required. The frame holder is designed to fit a standard 7.5-inch gel frame or top hat.

To remove and replace frame or top hat:

- Step 1. Disconnect luminaire AC input cable from power source.
- Step 2. At front lens, press upward on accessory frame latch and turn to open.
- Step 3. Remove frame/top hat, if any (**Figure 2-6**).
- Step 4. Install frame/top hat and close latch.

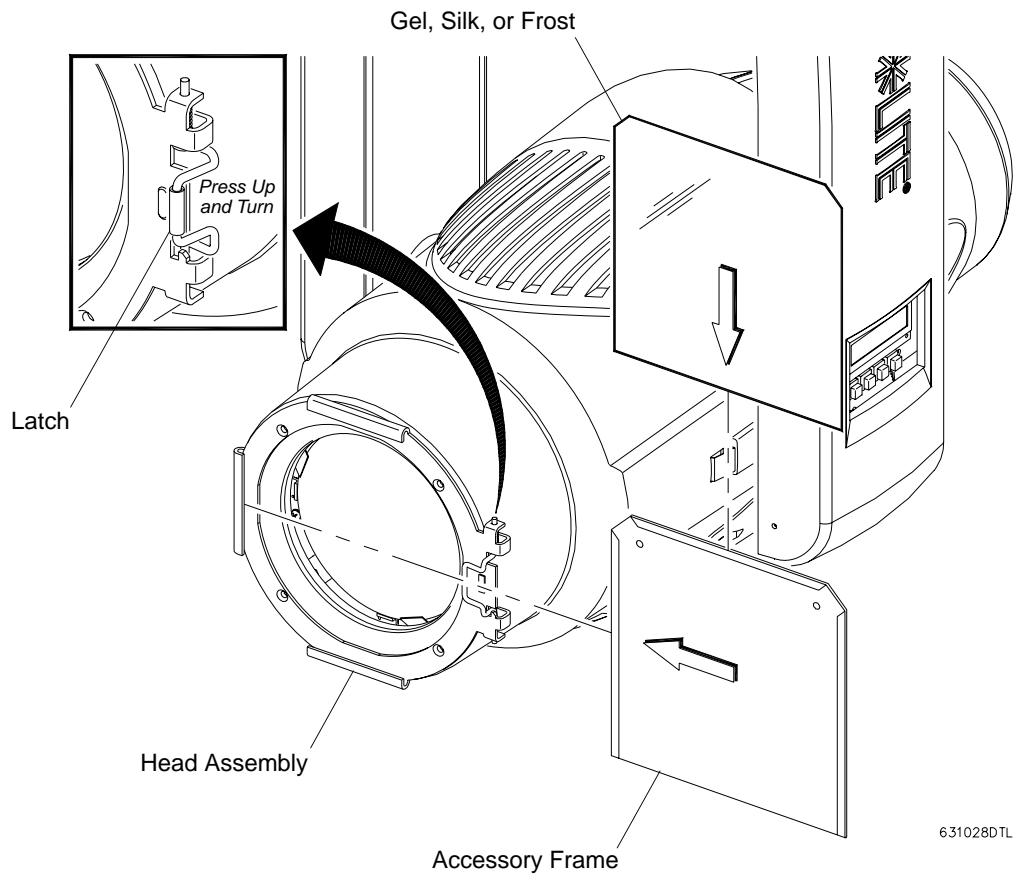

NOTE: _____
 The accessory frame is not a Vari-Lite accessory.

Figure 2-6: Installing a Frame or Top Hat

Front Cover Removal

Parts:

ASSY, FRONT COVER (22.9663.1038)

Tools:

#2 Phillips screwdriver

To remove and replace front cover:

- Step 1. Disconnect luminaire AC input cable from power source.
- Step 2. At head assembly, press in front cover latches to release (**Figure 2-7**).
- Step 3. Pull cover straight out until stopped by tether.
- Step 4. Disconnect tether by removing 8-32x1/2" PFB screw and 8-32 Keps nut as shown.
- Step 5. Remove cover.
- Step 6. Replace front cover by doing steps 2 through 5 in reverse. *Ensure latches lock into place.*

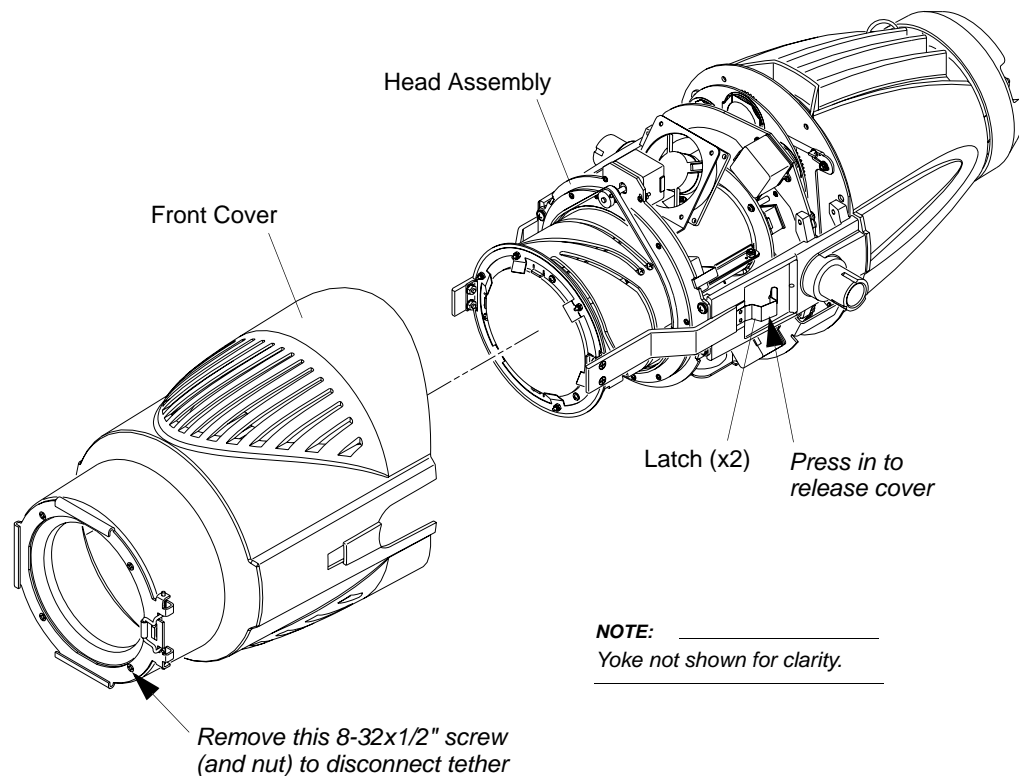

Figure 2-7: Front Cover Removal/Replacement

Rear Head Assembly Removal

This procedure is necessary in order to access some components such as the gobo wheel bulkhead and shutter assembly. Refer to as needed.

Tools:

#2 Phillips long handle screwdriver

To remove rear head assembly:

Step 1. Disconnect luminaire AC input cable from power source.



CAUTION: The rear head assembly is heavy and will remain attached by lamp wires. Place luminaire on tech bench before removing rear assembly.

Step 2. At side rails, remove four 10-32x5/8" PPB screws and #10 split lock washers (Figure 2-8). (Side rail spacers will come loose also.)

Step 3. Pull rear head assembly away from front head assembly.

Step 4. Re-install by doing steps 2 and 3 in reverse.

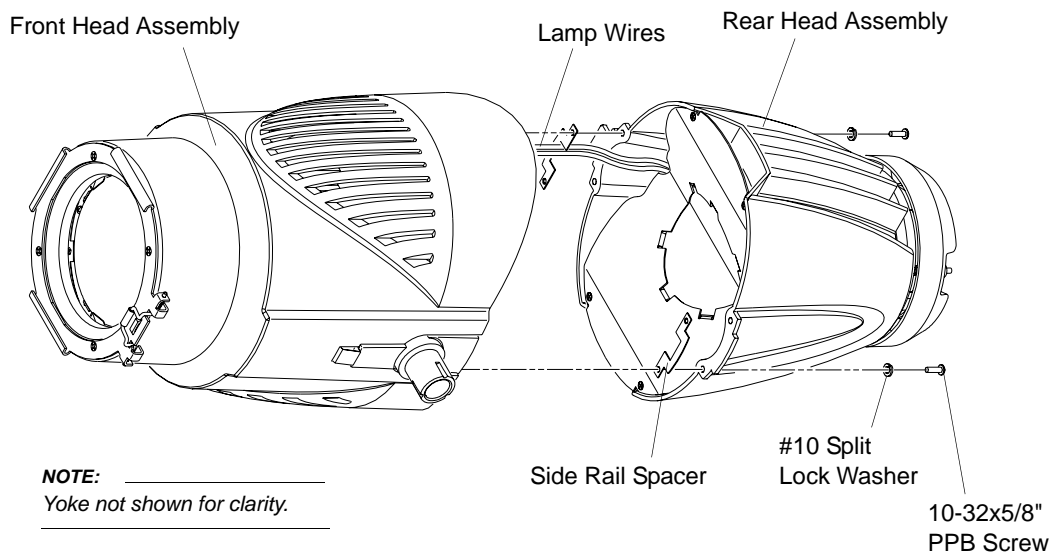

Figure 2-8: Rear Head Assembly Removal and Replacement

Rotating Gobo Replacement



WARNING: Remove power from luminaire before performing maintenance. Gobos may be HOT after operation. Allow to cool before replacing.



WARNING: Users of VARI*LITE luminaires should not install or use metal gobos. The use of metal gobos in any VARI*LITE product may damage the luminaire and could void the luminaire's warranty.

To replace a rotating gobo:

- Step 1. Remove power from luminaire.
- Step 2. At either side of head assembly, press in front cover latch and pull cover straight back until stopped by tether (**Figure 2-7**).
- Step 3. Rotate gobo wheel until required gobo position is accessible at finger access cutout (**Figure 2-9**).
- Step 4. Rotate gobo gear until open end of carrier is upward.



CAUTION: Do not touch gobos with bare fingers. Wear cotton gloves or other covering while replacing. Clean with glass cleaner and soft cloth if required.



CAUTION: Do not pull metal spring clip carrier back too far or it will not close properly.

- Step 5. If applicable, carefully pull current gobo up and out of carrier. *Gobo can be easily scratched on sides of carrier if not careful.*
- Step 6. Carefully install new gobo, orienting side marked "This Edge In" toward center of gobo wheel and side marked "Lamp Side" (mirror finish) toward lamp. *Gobo can be easily scratched on sides of carrier if not careful.* Ensure gobo is firmly set in carrier grooves.
- Step 7. Re-install front cover.

Rotating Gobo Replacement (continued)

CAUTION:

Gobo MUST be oriented with side marked "This Edge In" toward center of wheel and side marked "Lamp Side" toward lamp. If not oriented properly, gobo will break.

Be careful not to scratch gobo on side of carrier when installing.

Inside Edge
- orient toward center of wheel

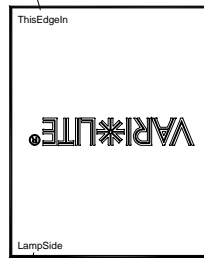

Lamp Side (mirrored)
- orient toward luminaire lamp

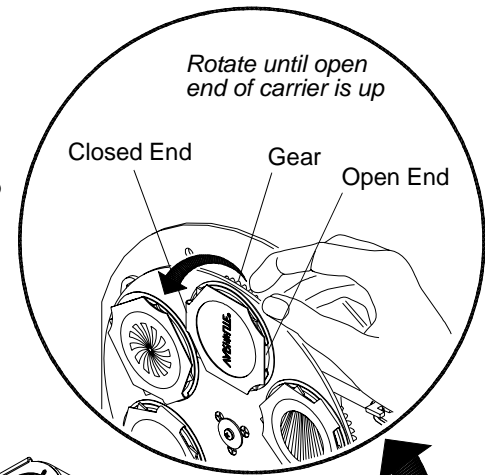
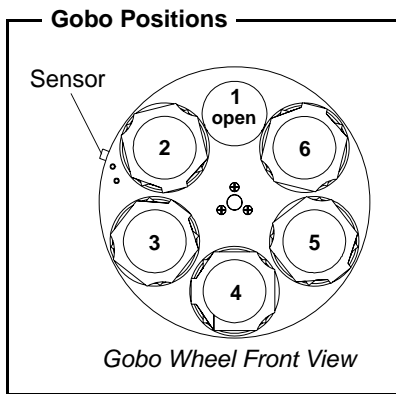

Front Cover

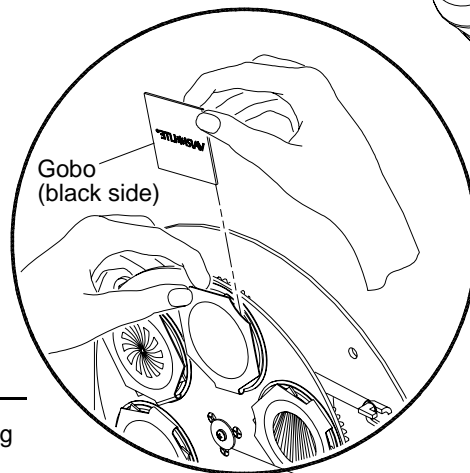

Latch

Rotating Gobo Wheel
Lamp End

CAUTION:

Be careful not to pull metal spring clip carrier back too far or it will not close properly.

Center of Wheel

Figure 2-9: Rotating Gobo Replacement/Cleaning

Gobo Index Timing Belt Alignment

The index timing belt (54.9663.1220) must be aligned so that the mechanism "clocks" properly. This belt is installed around the index gear and top gear of the gobo wheel (refer to [Figure 2-11](#)). The wheel position belt (54.2045.0002) is installed around the wheel position gear and bottom gear of the gobo wheel, and does not require alignment. Each belt is also routed around one pulley as shown in [Figure 2-11](#).

Note: The alignment procedure is the same for both arc and incandescent versions.

Use the following procedure to re-align the index timing belt in the event it slips or the gobo wheel is removed from the bulkhead. (This procedure assumes that the wheel has been removed from the bulkhead assembly. If you are simply re-aligning the belt, Step 2 can be skipped.)

To align index timing belt:

- Step 1. At large gear, align one of belt's *clock marks* with small groove at inside of gear. The *clock marks* will either be two ridges (newer belts) or one ridge and one red mark (older belts).

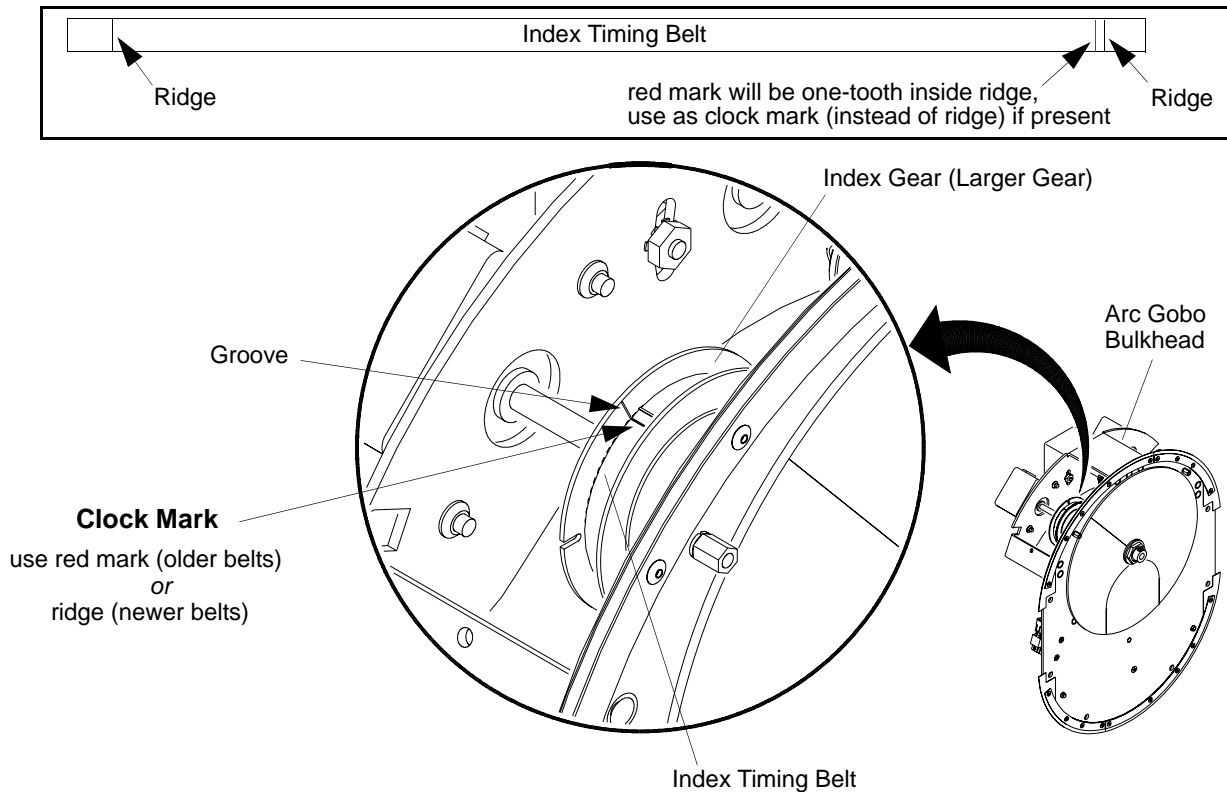

Figure 2-10: Aligning Index Gear Groove and Clock Mark

- Step 2. If applicable, lower gobo wheel into place over rotating shaft, fitting wheel position belt around lower gear and index timing belt around top gear. Install 4-40x1/4 " PPZ screw, split lock washer, flat black washer and flat Teflon washer to secure gobo wheel in place. (Belt tension is automatically set by springs of pivot mechanism.)
- Step 3. Orient gobo wheel so that notch of gobo wheel gear aligns with small ridge found on index timing belt.
- Step 4. Re-check alignment of *clock mark* with groove of index gear. Adjust as necessary until marks are perfectly aligned at both gears.

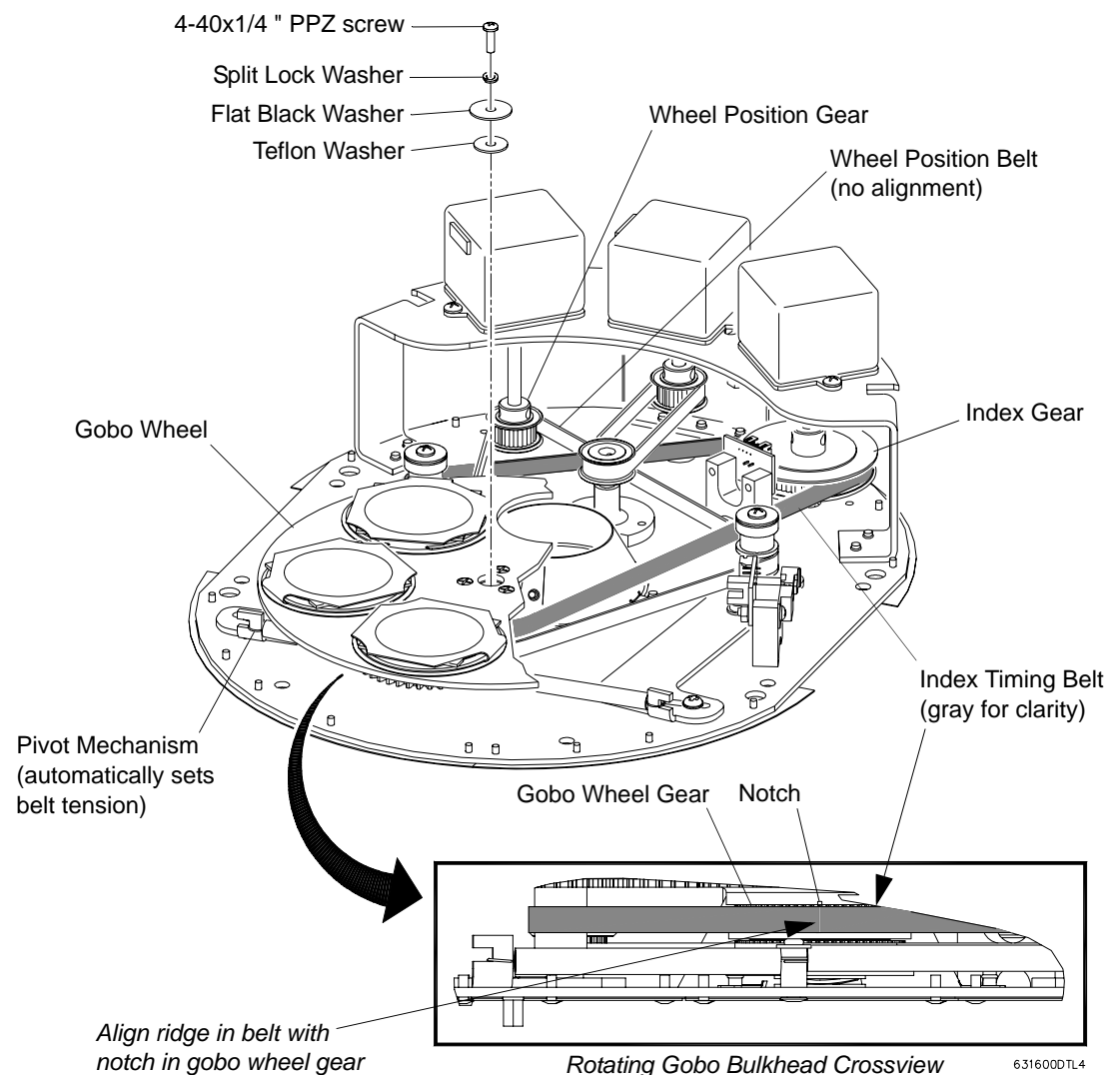

Figure 2-11: Aligning Second Clock Mark

Gobo Wheel Bulkhead Replacement

Parts:

ASSEMBLY, GOBO BULKHEAD INCANDESCENT (21.9663.1200) - TS/TI
ASSEMBLY, GOBO BULKHEAD ARC (21.9663.1600) - AS/AI

Tools:

#2 Phillips long handle screwdriver

To remove and replace gobo wheel bulkhead:

- Step 1. Disconnect luminaire AC input cable from power source.
Step 2. Remove front cover. Refer to [“Front Cover Removal” on page 26.](#)



CAUTION: The rear assembly is heavy and will remain attached by lamp wires. Place luminaire on tech bench before removing rear assembly.

- Step 3. At side rails, remove four 10-32x5/8" PPB screws and #10 split lock washers ([Figure 2-12](#)). (Side rail spacers will come loose also.) Pull rear head assembly away from front head assembly.
Step 4. At gobo bulkhead, disconnect all motor and sensor wiring.
Step 5. At side rails, remove four 10-32x3/8" PPB screws and #10 split-lock washers.
Step 6. Remove gobo bulkhead.
Step 7. Replace by doing steps 2 through 6 in reverse.

Gobo Wheel Bulkhead Replacement (continued)

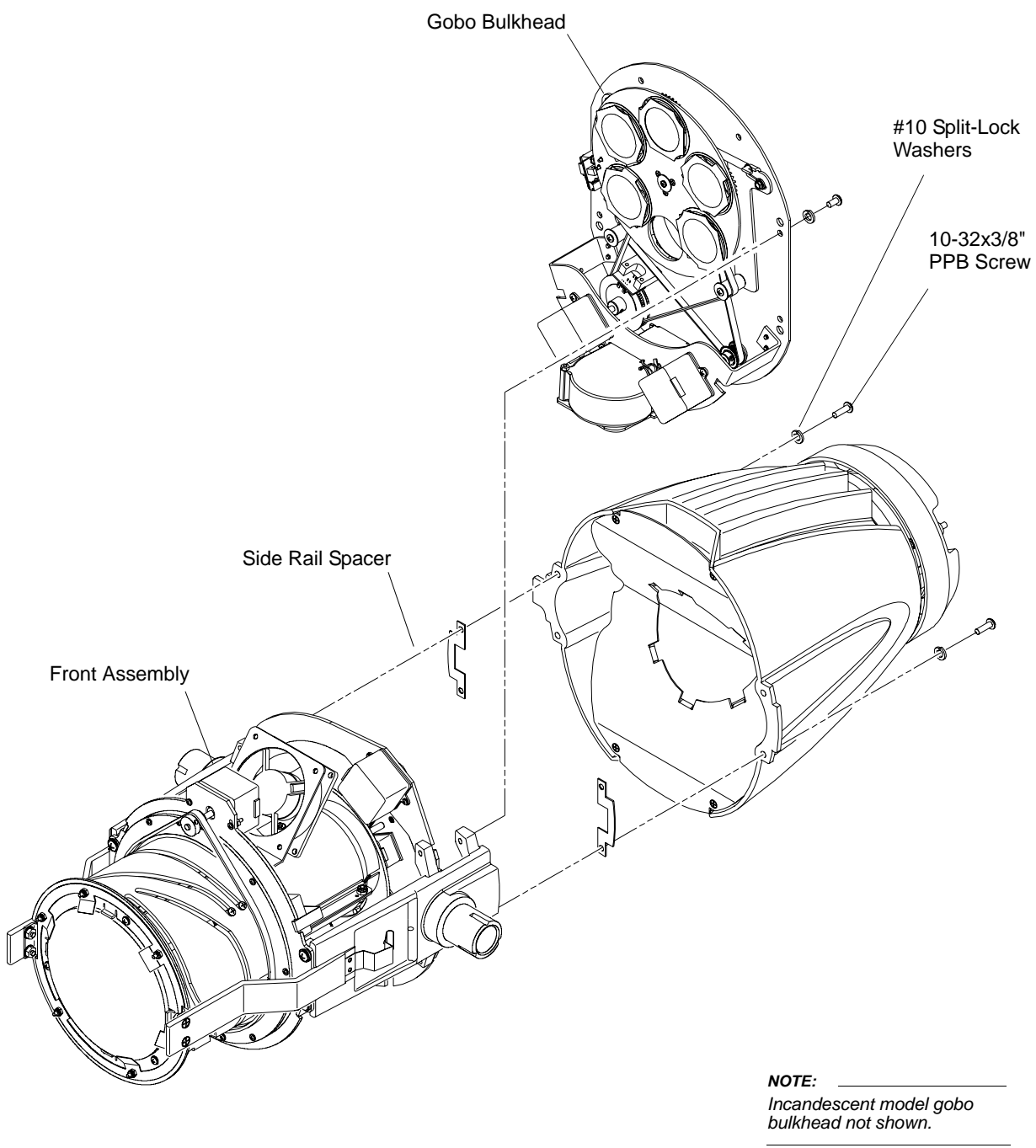

Figure 2-12: Gobo Bulkhead Assembly Replacement

Gobo Gear Planet Alignment

Each gear of the gobo wheel assembly must be aligned so that the gobos will index correctly. Use the following procedure to re-align the gears in the event the gobo wheel is disassembled.

To re-align gobo gears:

- Step 1. Place center (sun) gear at starting point so that alignment mark is directly facing Position 1 (open) as shown in **Figure 2-13**.
- Step 2. Set Position 6 planet gear as follows:
 - a. Rotate center gear clockwise until alignment mark is directly facing Position 6.
 - b. Lift edge of center gear slightly (so that it will not turn), while at same time rotating Position 6 gear until alignment mark is directly across from center gear alignment mark. Lower center gear into place and verify alignment.
- Step 3. Set Position 5 planet gear as follows:
 - a. Rotate center gear clockwise until alignment mark is directly facing Position 5.
 - b. Lift edge of center gear slightly (so that it will not turn), while at same time rotating Position 5 gear until alignment mark is directly across from center gear alignment mark. Lower center gear into place and verify alignment.
- Step 4. Set remaining planet gears by following same procedure. When all gears are aligned, rotate center gear in full rotation to verify alignments. When rotating, marks should align perfectly at each gear as they pass. Adjust as necessary and recheck.
- Step 5. Install flange, pulley and three 4-40x5/16" PFB screws to secure gears in place.

Gobo Gear Planet Alignment (continued)

1) Start with center gear alignment mark facing Position 1 (open).

2) Rotate center gear clockwise until alignment mark is directly across from Position 6. Rotate Position 6 gear until marks align.

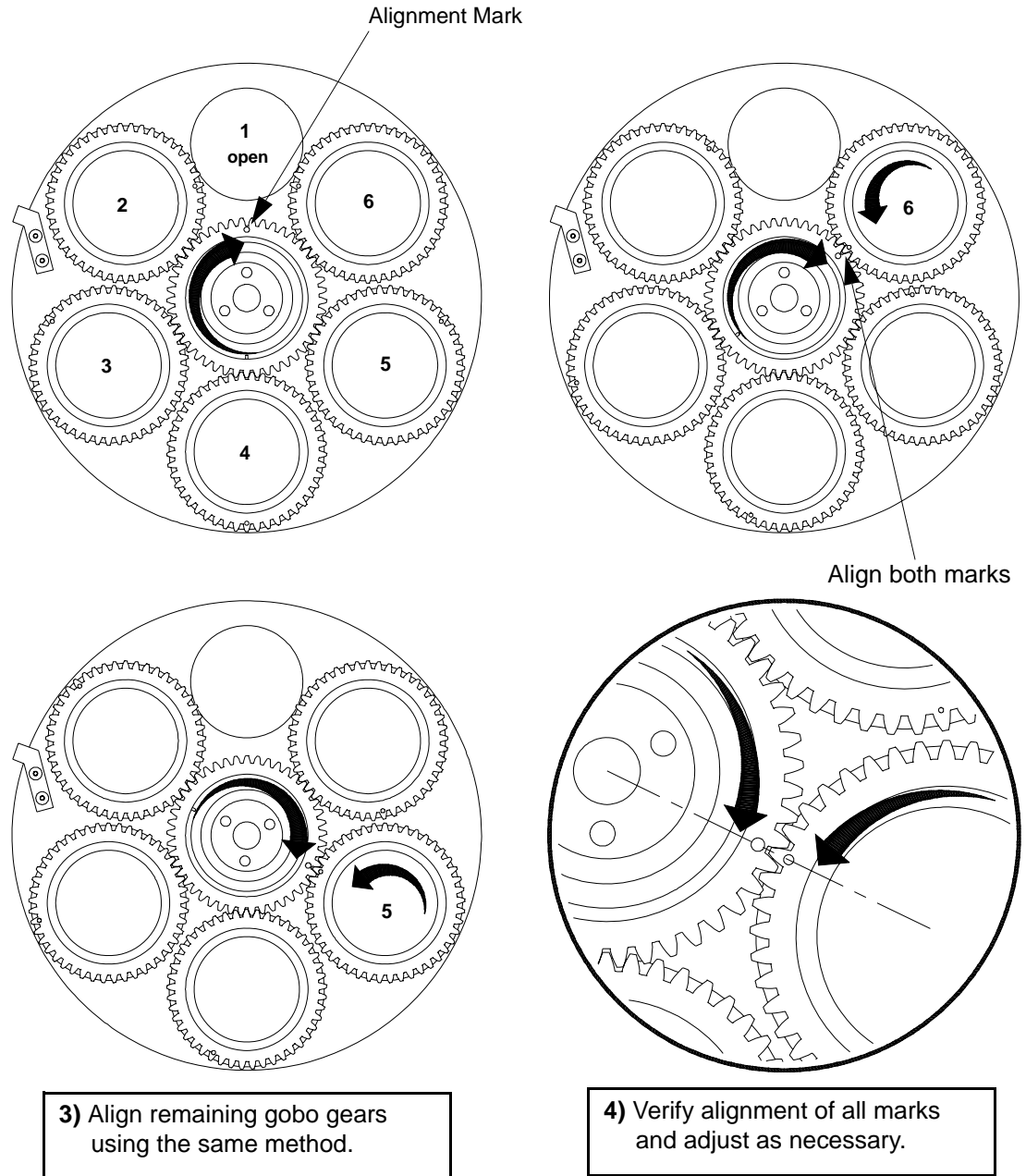

Figure 2-13: Aligning Gobo Wheel Gears

Shutter Assembly Replacement

Parts:

- ASSEMBLY, SHUTTER (21.9663.1300) (Old Version) *or*
- ASSEMBLY, SHUTTER 6 ROLLERS (21.9663.1350) (New Version)

Tools:

- #2 Phillips long handle screwdriver+

To remove and replace shutter assembly:

- Step 1. Disconnect luminaire AC input cable from power source.



CAUTION: The rear assembly is heavy and will remain attached by lamp wires. Place luminaire on tech bench before removing rear assembly.

- Step 2. Remove front cover, rear head assembly and gobo wheel bulkhead. Refer to [“Gobo Wheel Bulkhead Replacement”](#) on page 32.
- Step 3. Remove yoke leg cover (side with menu display) by removing two 6-32x1/2" PPB screws and two 6-32x3/8" PPB screws ([Figure 2-14](#)).

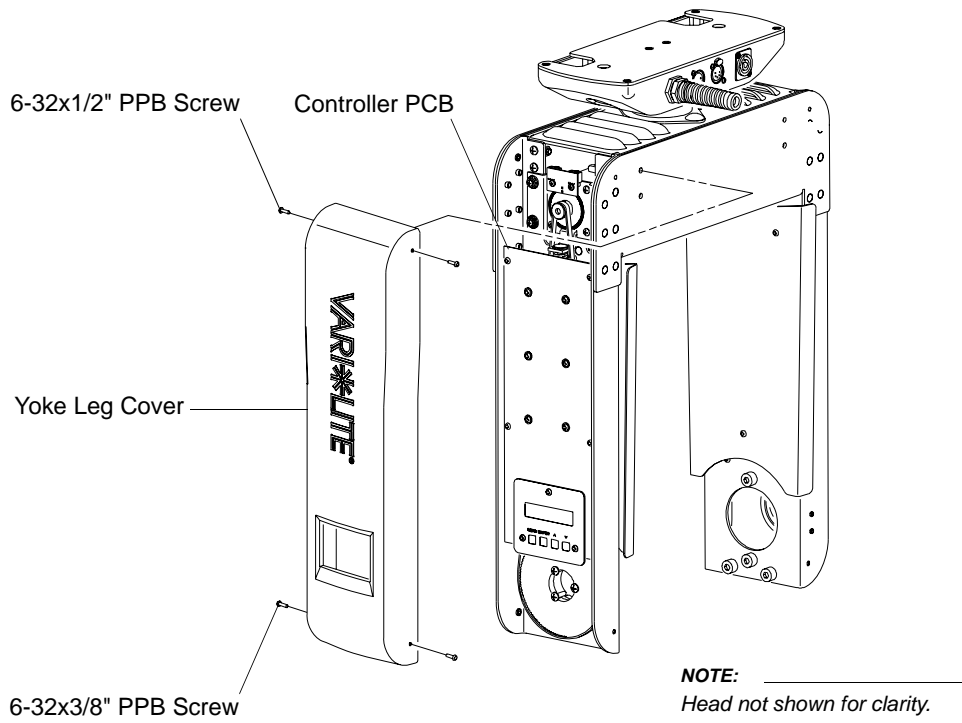

Figure 2-14: Removing Yoke Leg Cover to Access Controller PCB

- Step 4. At Controller PCB, disconnect shutter wiring harness at position marked SHUTTERS.
- Step 5. Noting placement, cut tie-wraps securing harness to other wires.
- Step 6. Feed shutter harness cable out of yoke arm.
- Step 7. At side rails, remove four 10-32x3/8" PPB screws and #10 split-lock washers and remove shutter assembly (**Figure 2-15**).



CAUTION: Do not overtighten tie-wraps when re-installing.

- Step 8. Replace shutter assembly by doing steps 2 through 7 in reverse.

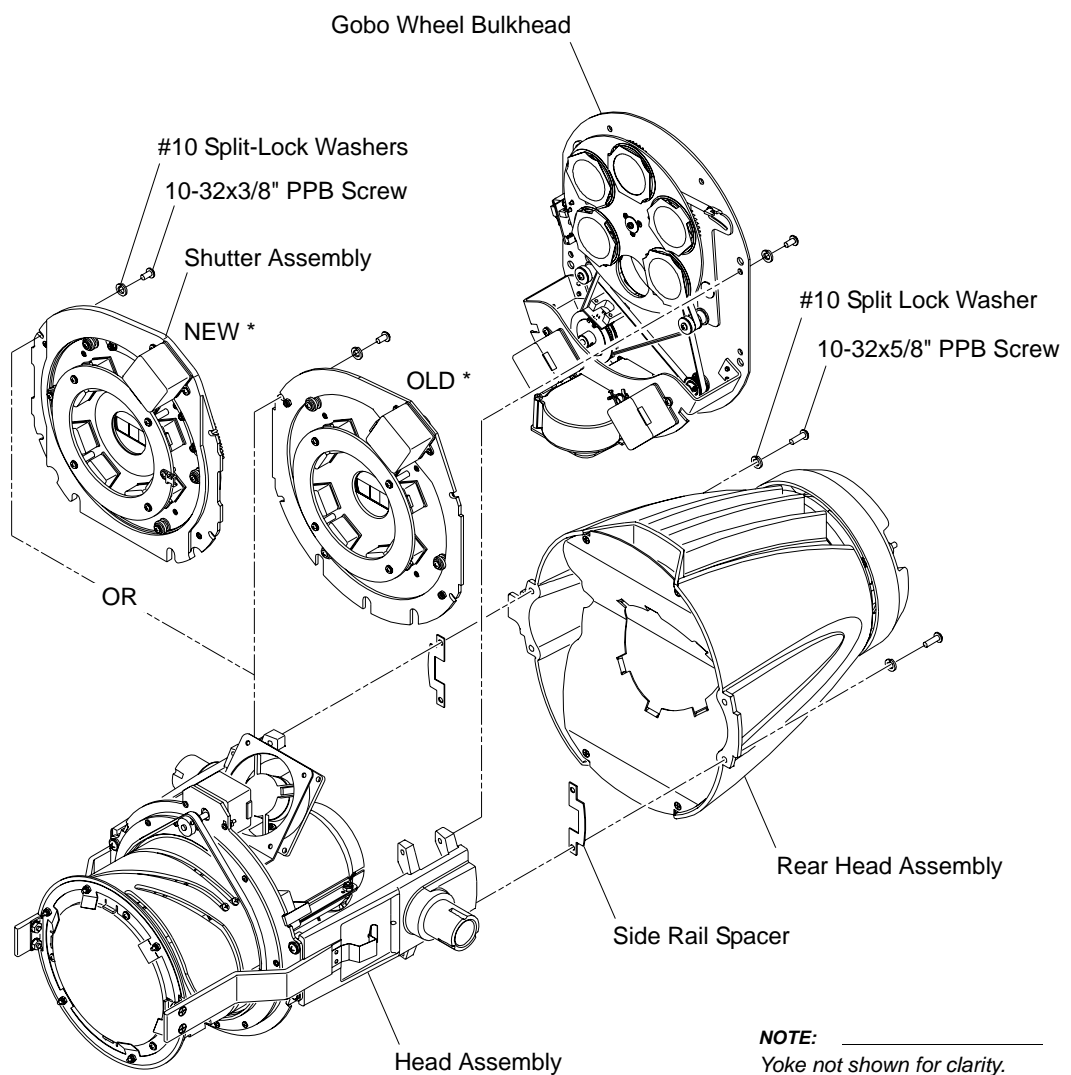

* Depending on when the luminaire was manufactured.

Figure 2-15: Shutter Assembly Replacement

Shutter Blade or Rack Replacement

Parts:

as required:

BLADE, SHUTTER, COATED SIDE A (12.9663.1323)

BLADE, SHUTTER, COATED SIDE B (12.9663.1324)

RACK, SHUTTER (10.9663.1314)

Tools:

#2 Phillips screwdriver

To remove and replace a shutter blade or rack:

- Step 1. Disconnect luminaire AC input cable from power source.
- Step 2. Remove shutter assembly. Refer to “[Shutter Assembly Replacement](#)” on [page 36](#).
- Step 3. Place shutter assembly on work bench, motor side down. Remove four 6-32x1/4" PFS screws and remove cover plate ([Figure 2-16](#)).

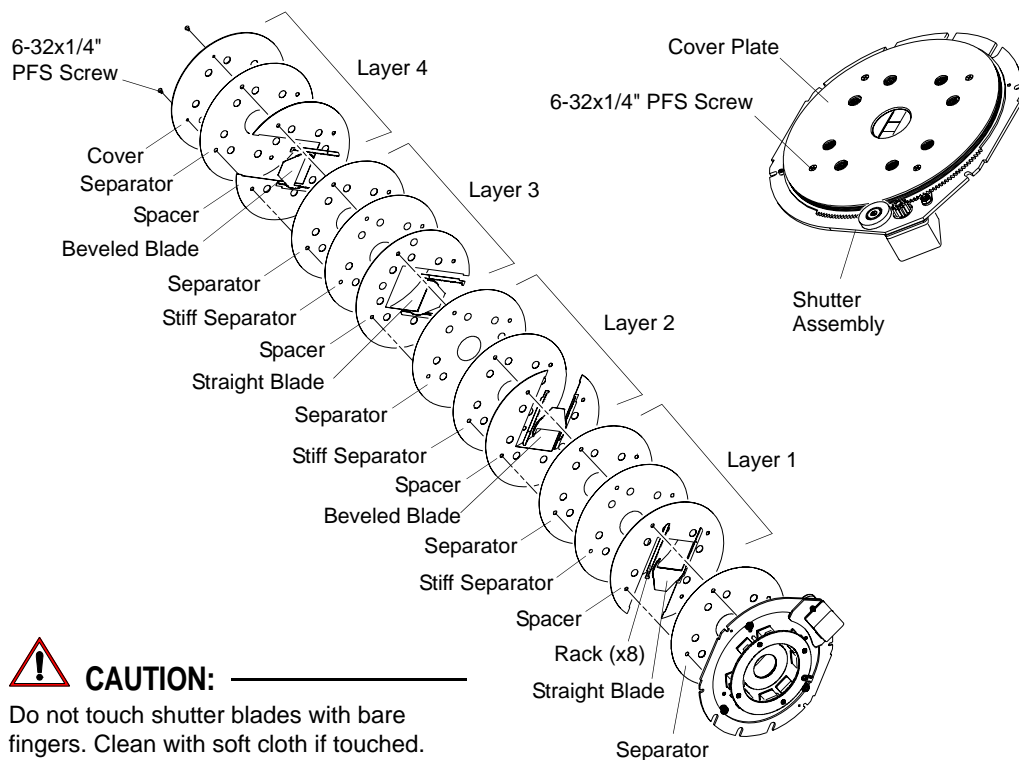

Figure 2-16: Shutter Assembly Breakdown

- Step 4. Carefully remove plates and components until blade or rack to be replaced is reached. Install new component(s) as required.
- Step 5. Re-assemble shutter's four layers. Ensure that components are oriented and aligned as shown in **Figure 2-17**.

Note: The difference between the two types of shutter blades can be found by examining the main edge. Coated Side A blades (12.9663.1323) are beveled and the Coated Side B blades (12.9663.1324) are not.

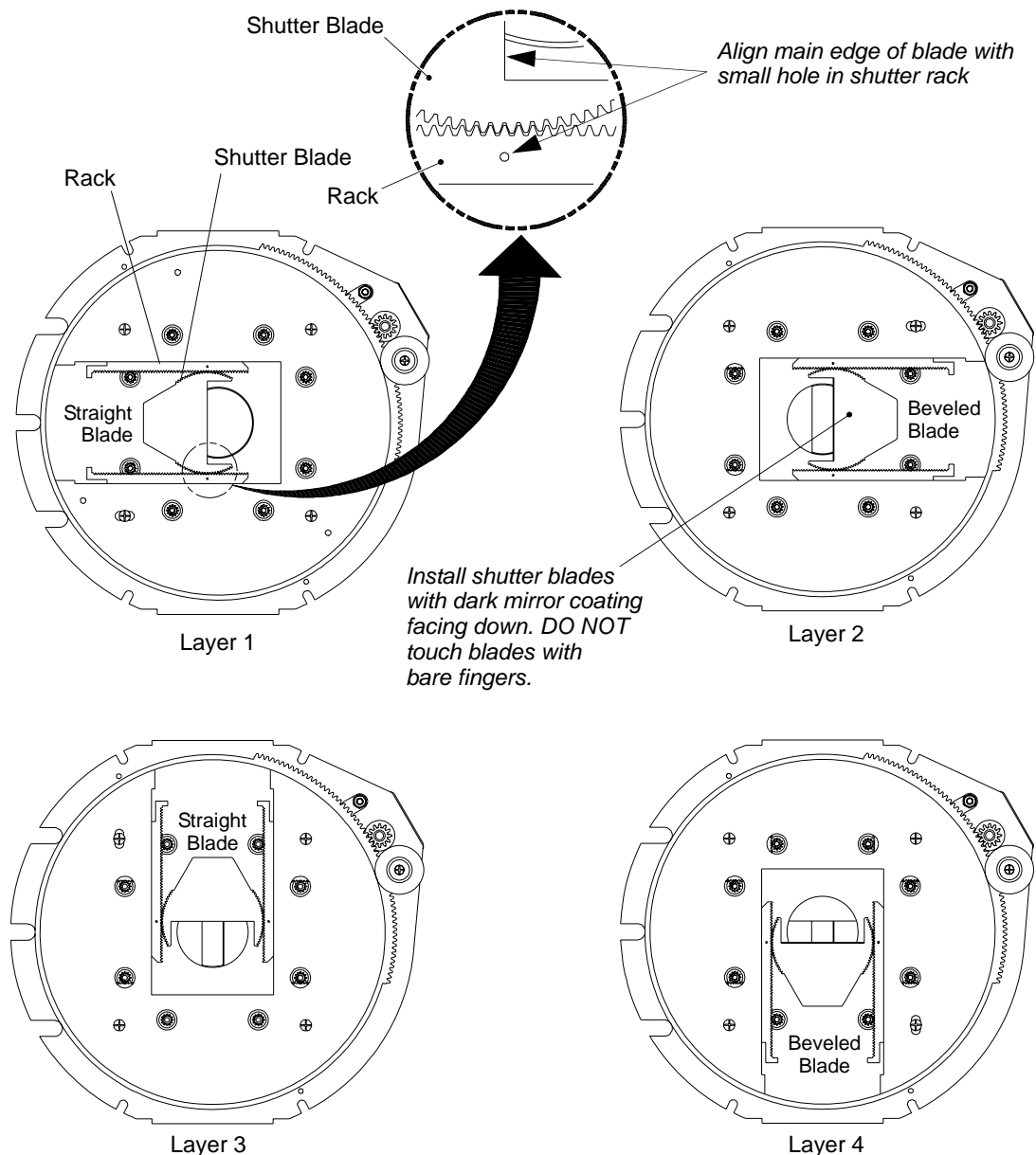

Figure 2-17: Shutter Assembly Layer Orientation

Edge/Zoom/Color Bulkhead Replacement

Parts:

ASSEMBLY, EDGE CONTROL, DIMMER AND COLOR (21.9663.1003)

Tools:

#2 Phillips screwdriver

To remove and replace edge/zoom/color bulkhead:

- Step 1. Disconnect luminaire AC input cable from power source.
- Step 2. Remove front cover. (Refer to “[Front Cover Removal](#)” on page 26.)
- Step 3. At edge/zoom/color assembly, disconnect wiring harness connections.
- Step 4. At side rail, remove four 8-32x1/2" PFB screws ([Figure 2-18](#)).
- Step 5. At front, remove four 8-32 Keps nuts and remove assembly.
- Step 6. Replace assembly by doing steps 2 through 5 in reverse.

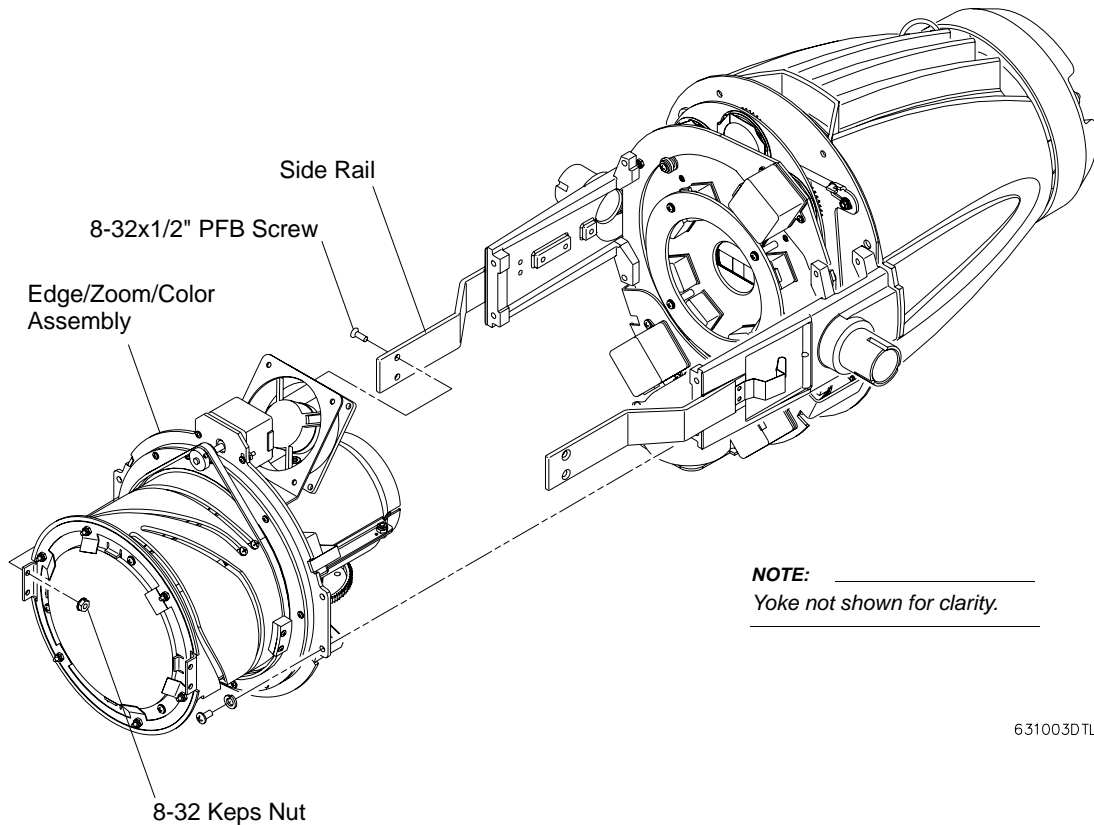

631003D TL

Figure 2-18: Edge/Zoom/Color Bulkhead Replacement

Fan/Temp Switch Assembly Replacement

Note: Fan does not operate under normal luminaire operating conditions.

Parts:

CABLE ASSEMBLY, FAN/TEMP SWITCH (23.9663.2009)

Tools:

#2 Phillips screwdriver

To remove and replace fan/temp switch assembly:

- Step 1. Disconnect luminaire AC input cable from power source.
- Step 2. Remove edge/dimmer/color bulkhead. Refer to “[Edge/Zoom/Color Bulkhead Replacement](#)” on page 40.
- Step 3. At fan, remove four 6-32 x 3/8 " PPSS black screws and 6-32 nylon insert hex nuts and remove fan/temp switch assembly (**Figure 2-19**).
- Step 4. Replace assembly by doing steps 2 and 3 in reverse.

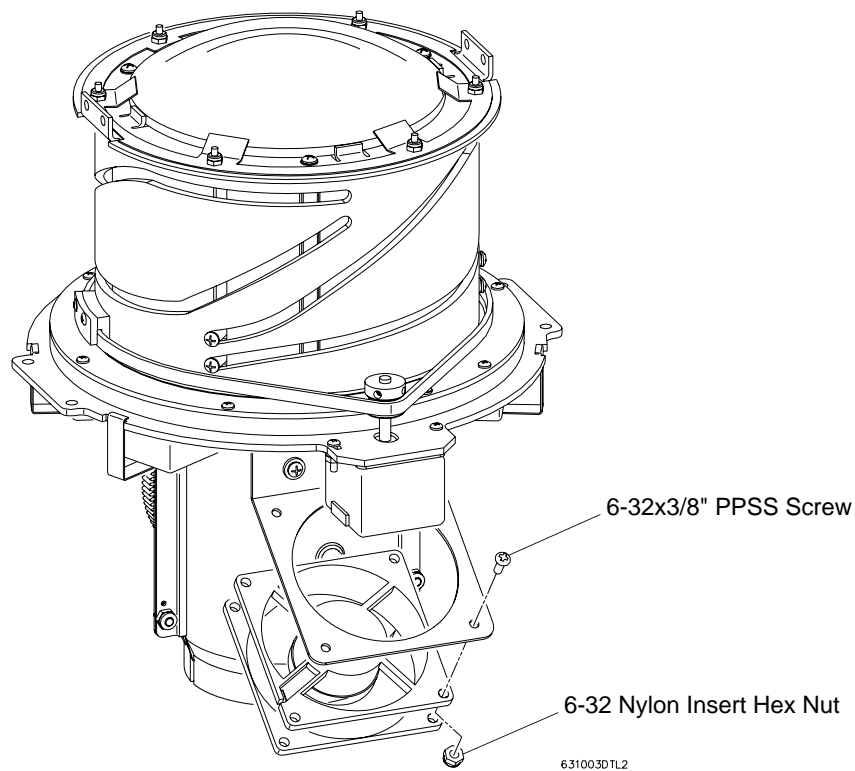

Figure 2-19: Fan/Temp Switch Assembly Replacement

Beam-Size Iris Assembly Replacement

Note: This procedure not applicable to all units.

Parts:

ASSEMBLY, IRIS (21.9663.1400)

Tools:

#2 Phillips screwdriver

To remove and replace beam-size iris assembly:

- Step 1. Disconnect luminaire AC input cable from power source.
- Step 2. Remove front cover. Refer to “[Front Cover Removal](#)” on page 26.
- Step 3. At beam-size iris assembly, disconnect motor connectors ([Figure 2-20](#)).
- Step 4. At side rails, remove four 10-32x3/8" PPB screws and #10 split-lock washers and remove iris assembly.
- Step 5. Replace iris assembly by doing steps 2 through 4 in reverse.

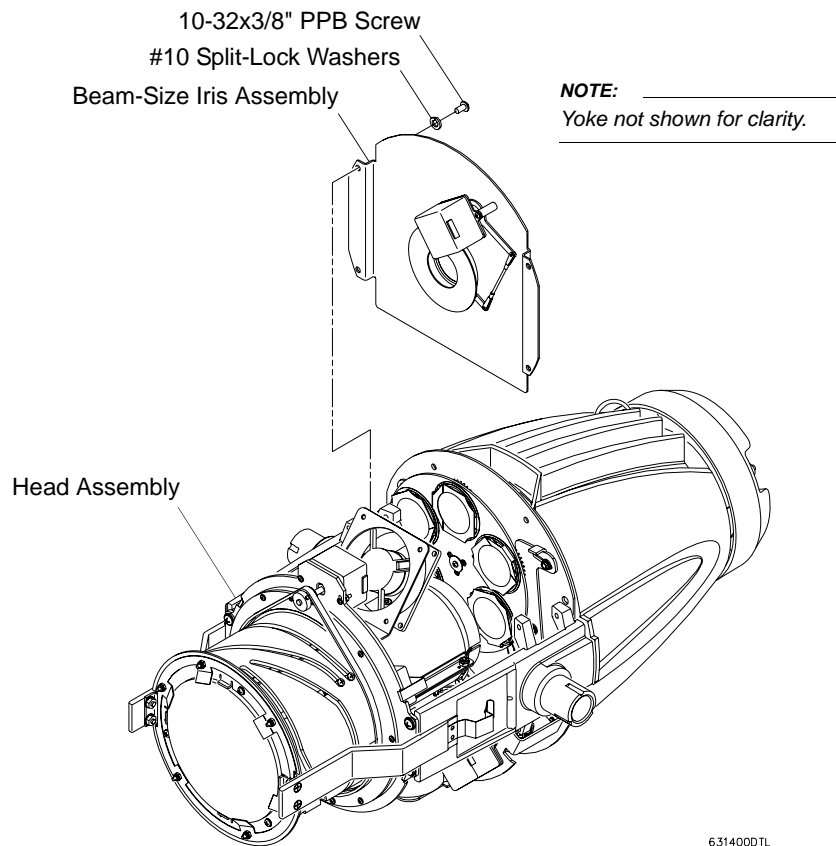

Figure 2-20: Beam-Size Iris Assembly Replacement

Ignitor PCB Replacement

Note: This procedure not applicable to all units.

Parts:

PCB ASSEMBLY, IGNITOR (24.9661.3126)

Tools:

#2 Phillips screwdriver

To remove and replace ignitor PCB:

- Step 1. Disconnect luminaire AC input cable from power source.
- Step 2. Remove yoke leg cover (side without menu display) by removing four 6-32x3/8" PTB screws as shown in **Figure 2-21**.
- Step 3. At ignitor PCB, disconnect lamp connectors.
- Step 4. Remove four 6-32x3/8" PPB screws and remove ignitor PCB.
- Step 5. Replace ignitor PCB by doing steps 2 through 4 in reverse.

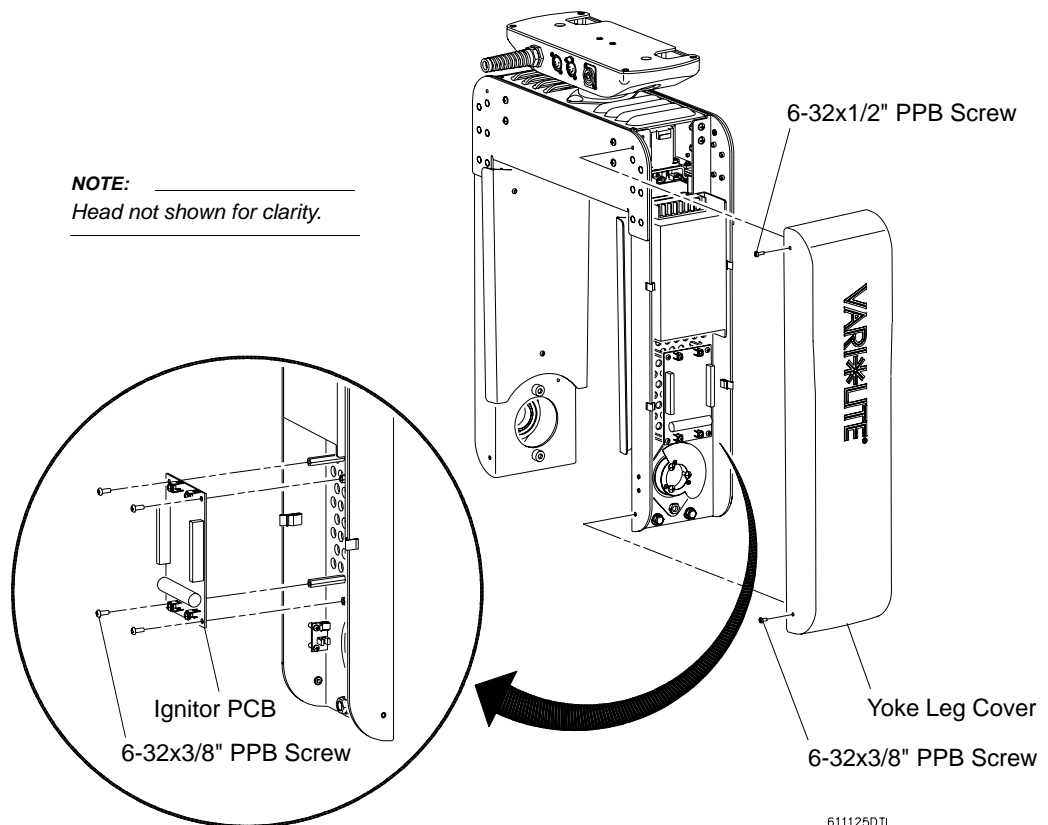

Figure 2-21: Ignitor PCB Replacement

Power Supply Replacement

Parts:

POWER SUPPLY, 130W +24V/6.3A (69.3177.0151)

Tools:

#1 Phillips screwdriver, 5/16 inch nutdriver

To remove and replace power supply:

- Step 1. Disconnect luminaire AC input cable from power source.
- Step 2. Remove yoke leg cover (side without menu display) by removing four 6-32x3/8" PTB screws as shown in [Figure 2-23](#).
- Step 3. At power supply, disconnect all connectors.
- Step 4. Loosen two 4-40x1/2" PPZ screws and remove one 4-40x1/2" PPZ screw. Remove power supply.
- Step 5. Replace LVS. Reconnect all cables as follows:

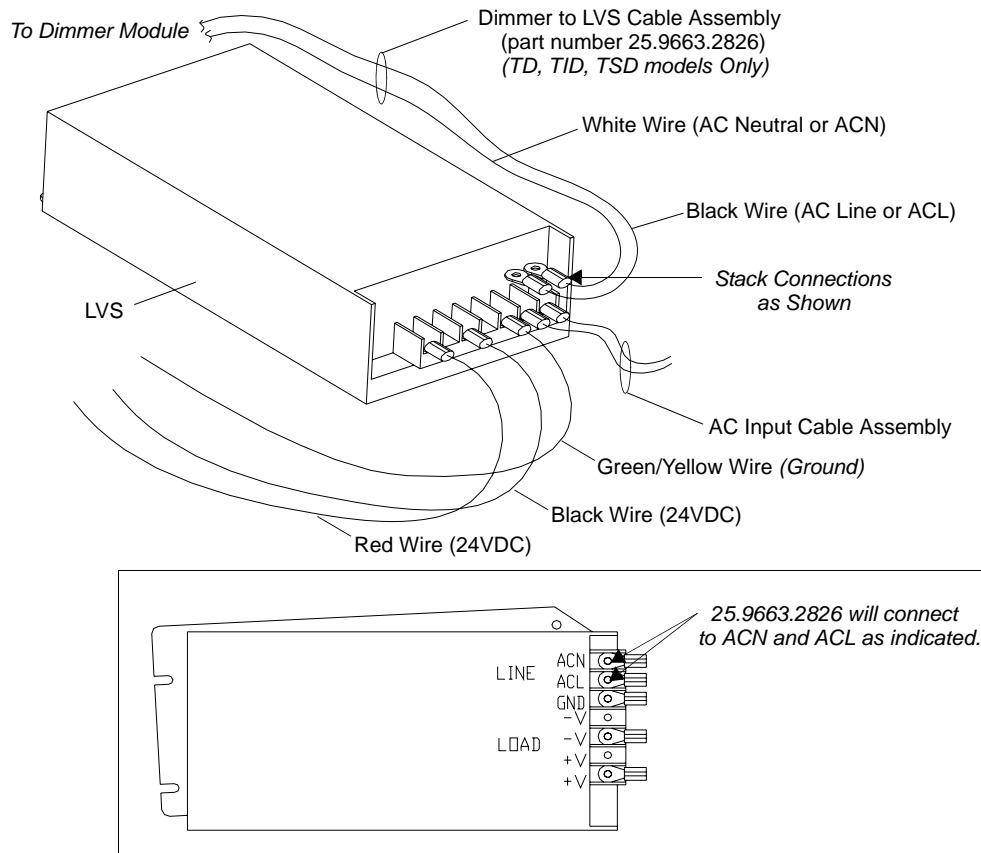

Figure 2-22: VL1000 Low-Voltage Supply (LVS)

Power Supply Replacement (continued)

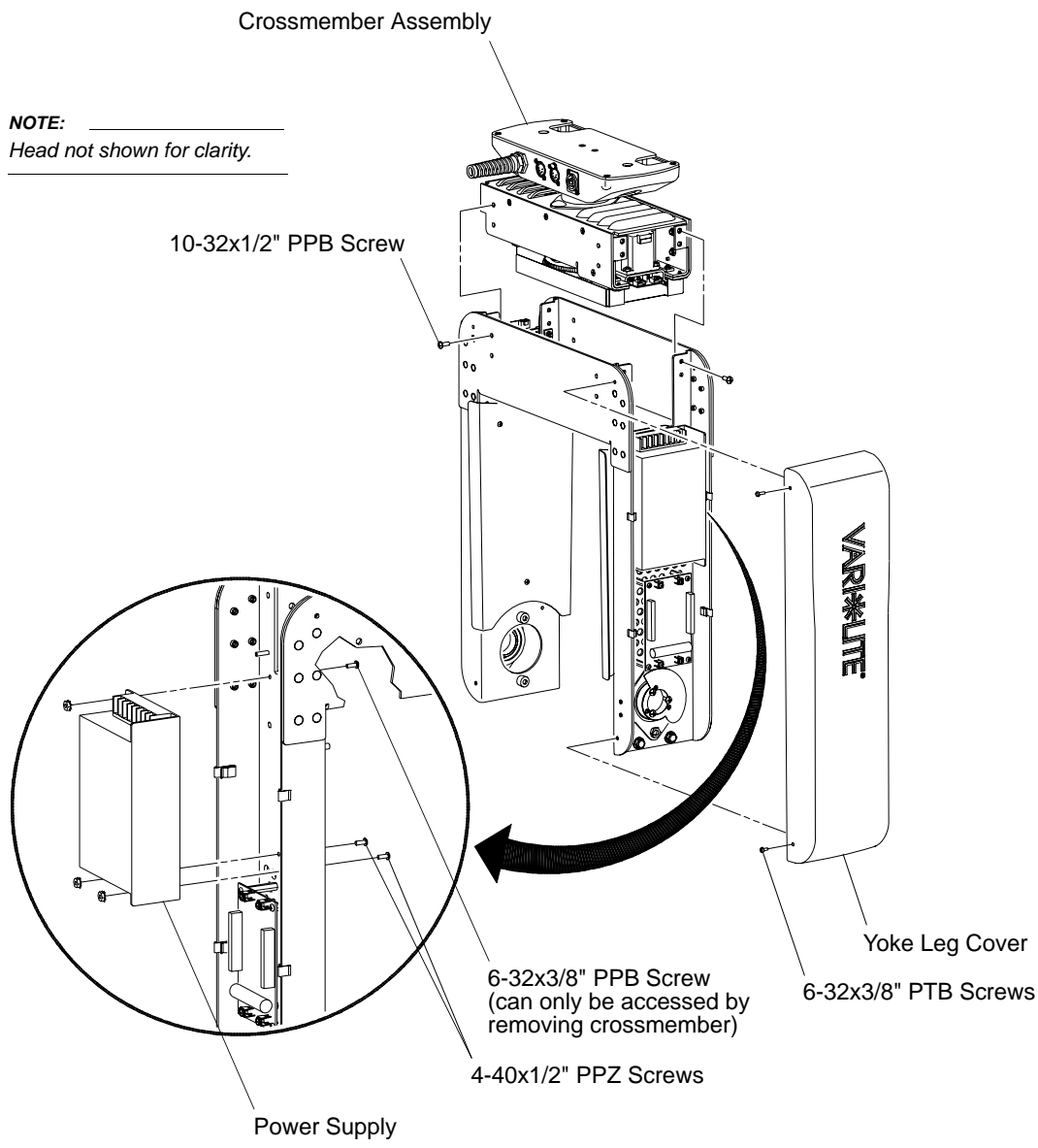

Figure 2-23: Power Supply Replacement

Controller PCB Replacement

Parts:

PCB ASSEMBLY, CONTROLLER (24.9663.3930)

Tools:

#1 Phillips screwdriver

To remove and replace controller PCB:

- Step 1. Disconnect luminaire AC input cable from power source.
- Step 2. Remove yoke leg cover (side with menu display) by removing four 6-32x3/8" PTB screws as shown in [Figure 2-24](#).
- Step 3. Remove display overlay and plate, by removing three 6-32x1/2" PPB screws.
- Step 4. At controller PCB, disconnect wiring at connectors marked:
 - a. GOBO/COLOR/ZOOM/EDGE/DIMMER/ROTATE
 - b. PAN/TILT
 - c. POWER
 - d. COMM
 - e. SHUTTERS (if applicable)
 - f. BALLAST (if applicable)
- Step 5. At controller PCB, remove four 6-32x3/8" PPB screws and remove PCB.
- Step 6. Replace controller PCB by doing steps 2 through 5 in reverse.

Controller PCB Replacement (continued)

NOTE: _____
Head not shown for clarity.

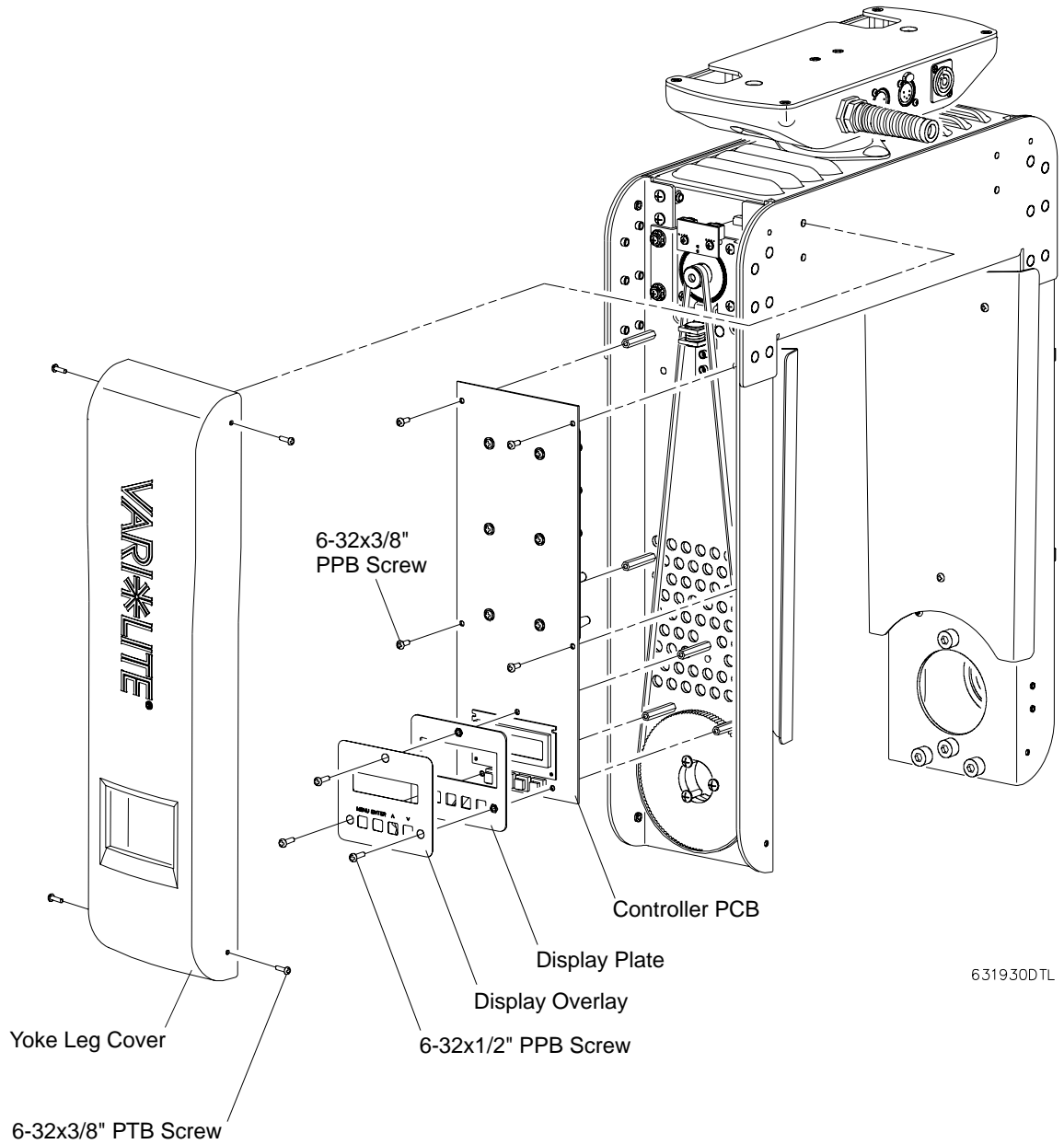

Figure 2-24: Controller PCB Replacement

Tilt Encoder PCB Replacement

Parts:

PCB ASSY, PAN/TILT ENCODER (24.9661.9629)

Tools:

#2 Phillips screwdriver

To remove and replace tilt encoder PCB:

- Step 1. Disconnect luminaire AC input cable from power source.
- Step 2. Remove yoke leg cover (side with menu display) by removing four 6-32x3/8" PTB screws.
- Step 3. As shown in **Figure 2-25**, at tilt encoder PCB, remove two 4-32 screws.
- Step 4. Disconnect connectors at J1 and J2.
- Step 5. Remove encoder PCB.
- Step 6. Replace encoder PCB by doing steps 2 through 5 in reverse.

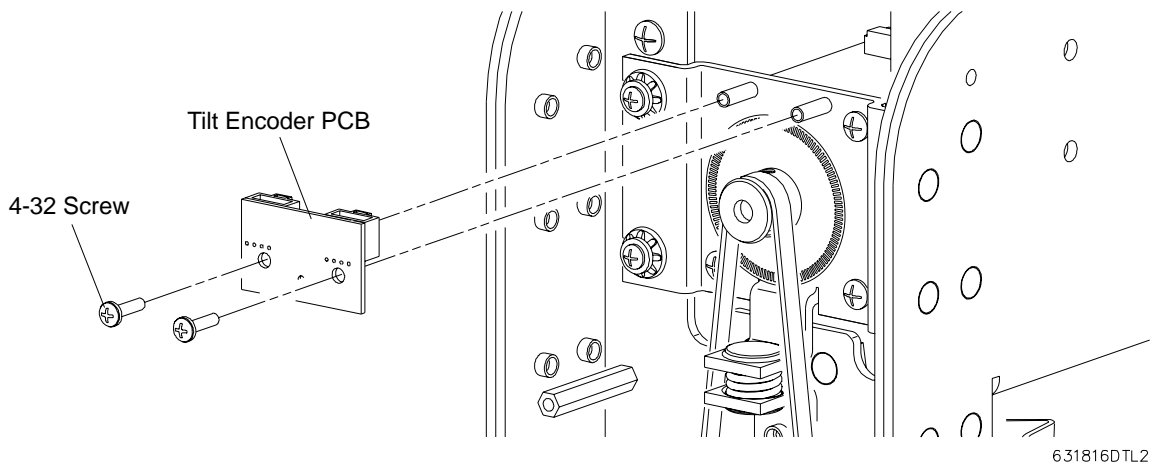

Figure 2-25: Tilt Encoder PCB Replacement

Tilt Motor Assembly Replacement

Parts:

ASSEMBLY, TILT MOTOR (21.9663.1816)

Tools:

#2 Phillips screwdriver

To remove and replace tilt motor assembly:

- Step 1. Disconnect luminaire AC input cable from power source.
- Step 2. Remove yoke leg cover (side with menu display) by removing four 6-32x3/8" PTB screws ([Figure 2-26](#)).
- Step 3. Remove display overlay and plate, by removing three 6-32x1/2" PPB screws.
- Step 4. At controller PCB, disconnect wiring at connectors marked:
- a. GOBO/COLOR/ZOOM/EDGE/DIMMER/ROTATE
 - b. PAN/TILT
 - c. POWER
 - d. COMM
 - e. SHUTTERS (if applicable)
 - f. BALLAST (if applicable)
- Step 5. Remove four 6-32x3/8" PPB screws and remove controller PCB.
- Step 6. At encoder PCB, remove two 4-32 screws.
- Step 7. Disconnect connectors at J1 and J2 and remove encoder PCB.
- Step 8. At tilt motor assembly, loosen four 6-32x1" PPB screws. Slide assembly forward and remove belt from pulley.
- Step 9. Remove four 6-32x1" PPB screws and #6 flat washers and remove tilt motor assembly (spring will come loose also).
- Step 10. Replace by doing steps 2 through 9 in reverse. (Belt tension is automatically set by spring.)

Tilt Motor Assembly Replacement (continued)

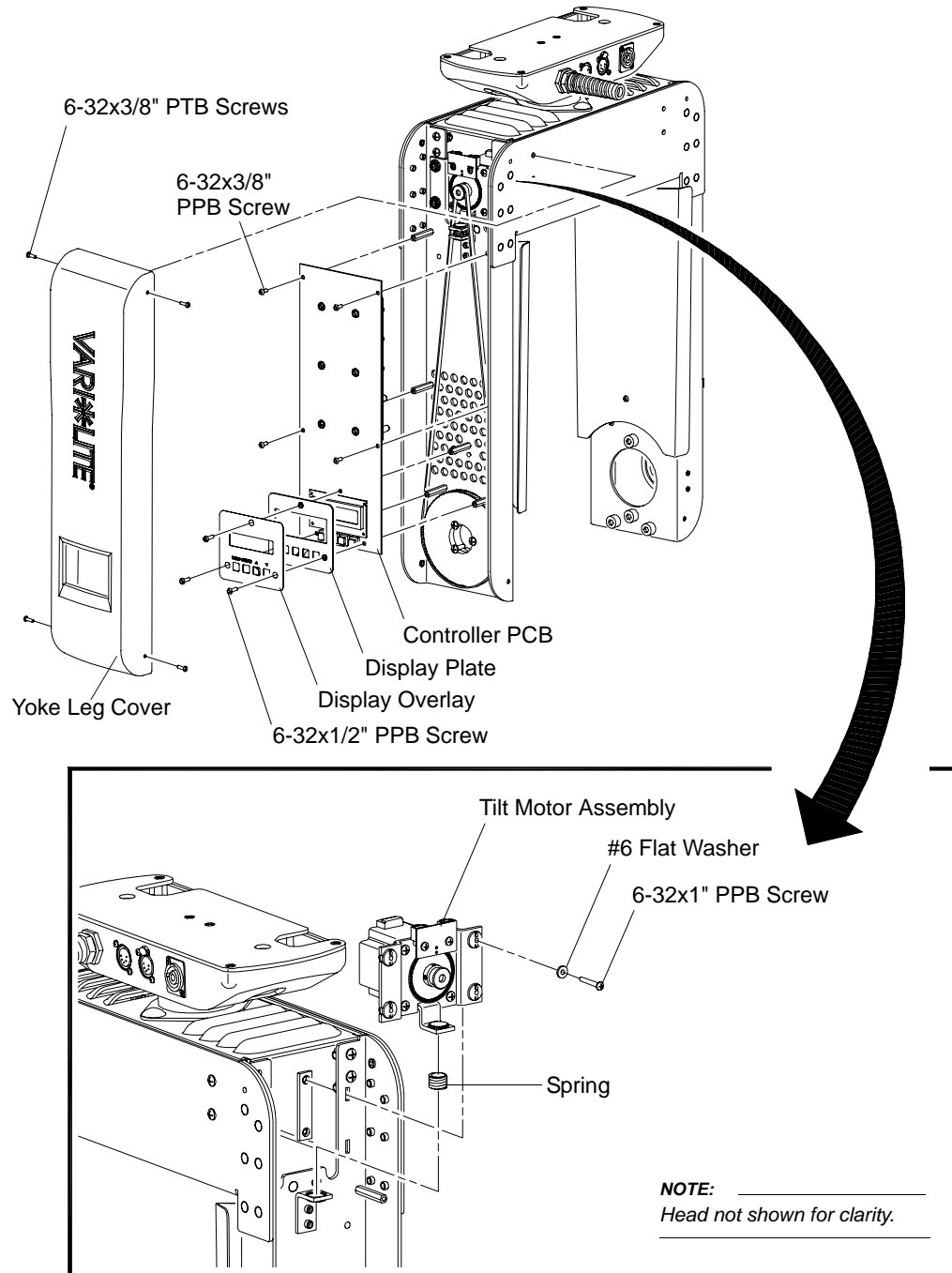

Figure 2-26: Tilt Motor Assembly Replacement

Pan Motor Assembly Replacement

Parts:

ASSEMBLY, PAN MOTOR (21.9663.1815)

Tools:

#2 Phillips screwdriver

To remove and replace pan motor assembly:

- Step 1. Disconnect luminaire AC input cable from power source.
- Step 2. Remove yoke leg covers by removing four 6-32x3/8" PTB screws on each side ([Figure 2-27](#)).
- Step 3. Remove crossmember assembly from yoke by removing sixteen 10-32x1/2" PPB screws.
- Step 4. At crossmember assembly, remove pan wire shield by removing four 4-40x3/8" PPZ screws.
- Step 5. At pan motor assembly, loosen four 6-32x1" PPB screws. Slide assembly forward and remove belt from pulley.
- Step 6. Remove four 6-32x1" PPB screws and #6 flat washers and remove pan motor assembly (nut plate will come loose also).
- Step 7. Replace pan motor assembly by doing steps 2 through 6 in reverse. (Belt tension is automatically set by spring.)

Pan Motor Replacement (continued)

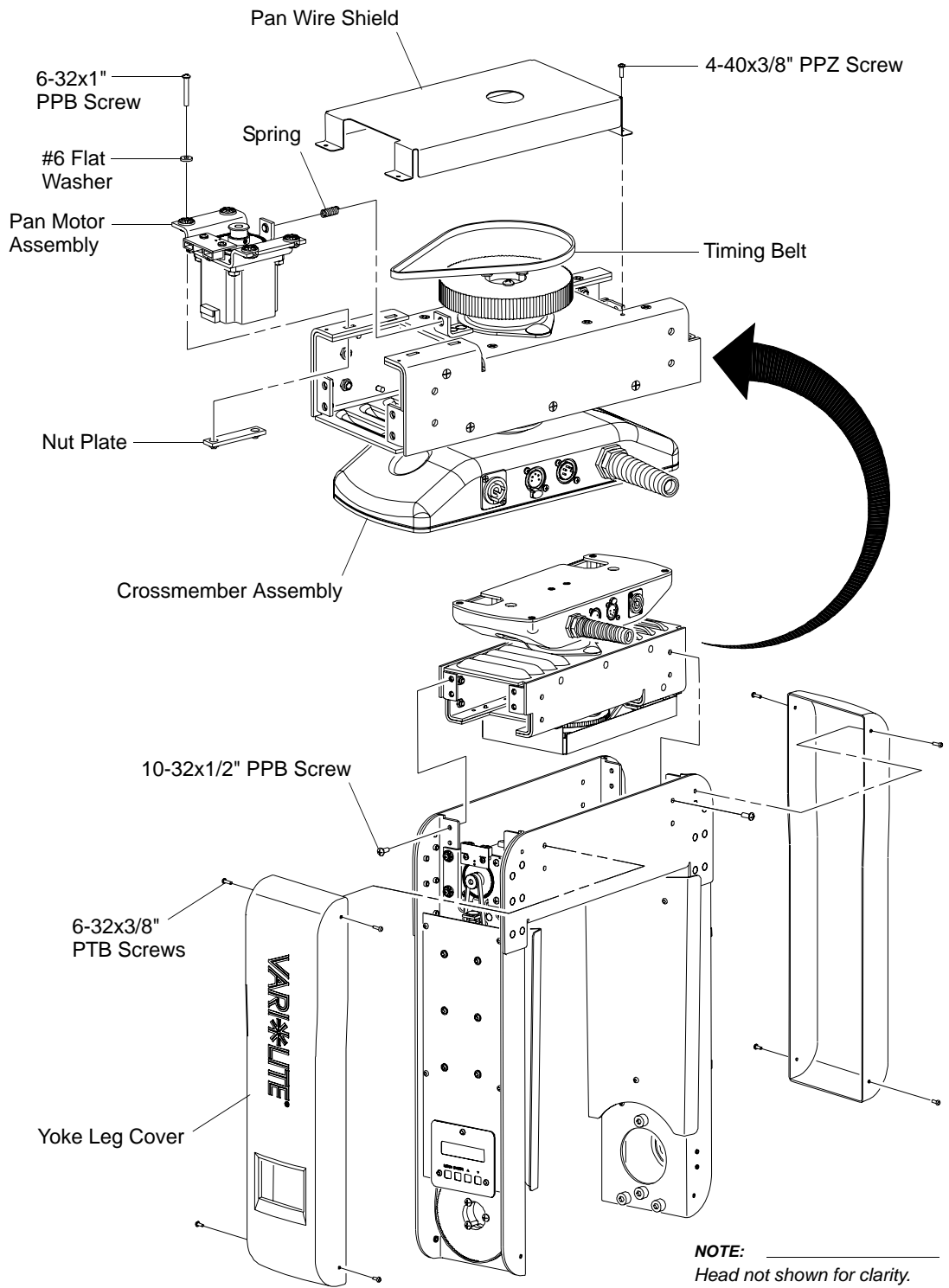

Figure 2-27: Pan Motor Assembly Replacement

DMX Input PCB Replacement

Parts:

PCB ASSEMBLY, DMX INPUT (24.9663.3895)

Tools:

#2 Phillips screwdriver

To remove and replace DMX input PCB:

- Step 1. Disconnect luminaire AC input cable from power source.
- Step 2. At pan tube cover, remove four 8-32x3/8" PFZ screws and remove cover (**Figure 2-28**).
- Step 3. Remove four #4x3/8" HiLo screws.
- Step 4. Disconnect DMX input PCB wiring and remove PCB.
- Step 5. Replace DMX input PCB by doing steps 2 through 4 in reverse.

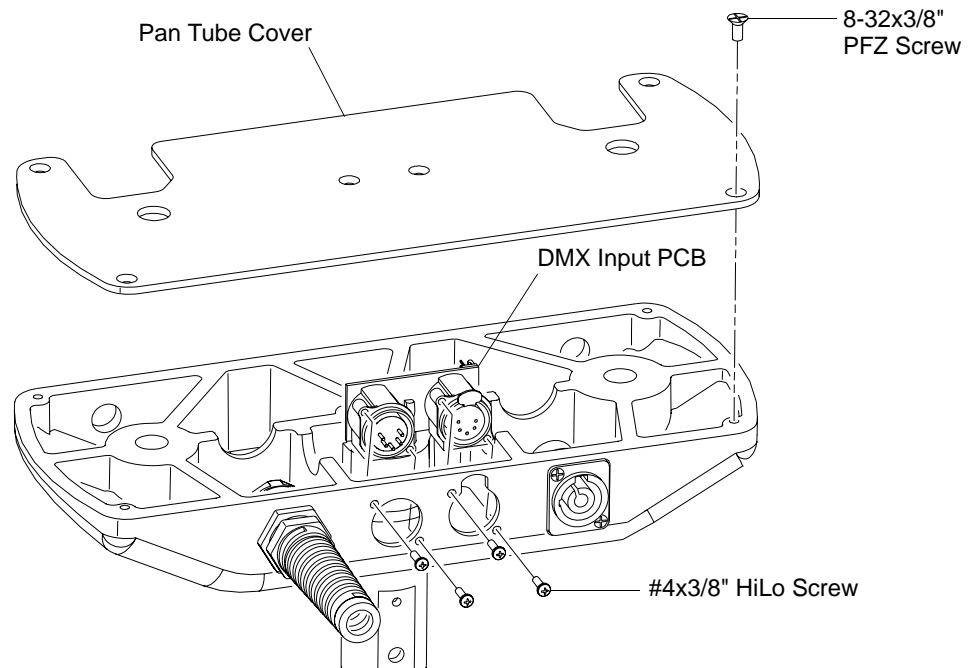

Figure 2-28: DMX Input PCB Replacement

Cleaning Optical Lenses and Filters



WARNING: Remove power from luminaire before performing maintenance.

The front lens, color filters, and gobos may require cleaning after extended use. Isopropyl Alcohol should only be used, with a soft, lint-free cloth, to clean these components.

To access gobos, refer to [“Rotating Gobo Replacement”](#) on page 28.

CHAPTER 3.

Illustrated Parts Breakdown

This chapter contains illustrated parts breakdowns for all VL1000™ ERS Luminaire assemblies.

- **Drawing Trees**
- **Top Assembly**
- **Head Assembly**
- **Yoke Assembly**
- **Cables**
- **Arc Ballast Assembly**

The following abbreviations are used to identify parts specific to certain models:

ABBREVIATION	MODEL
TI	VL1000 Incandescent Luminaire w/ Beam-Size Iris
TS	VL1000 Incandescent Luminaire w/ Shutter System
AI	VL1000 Arc Luminaire with Beam-Size Iris
AS	VL1000 Arc Luminaire with Shutter System
TSD	VL000 Incandescent with 115V Dimmer and Shutter System
TID	VL000 Incandescent with 115V Dimmer and Beam-Size Iris
TSE	VL000 Incandescent with 240V Dimmer and Shutter System
TIE	VL000 Incandescent with 240V Dimmer and Beam-Size Iris



Drawing Trees

VL1000 Incandescent Luminaires

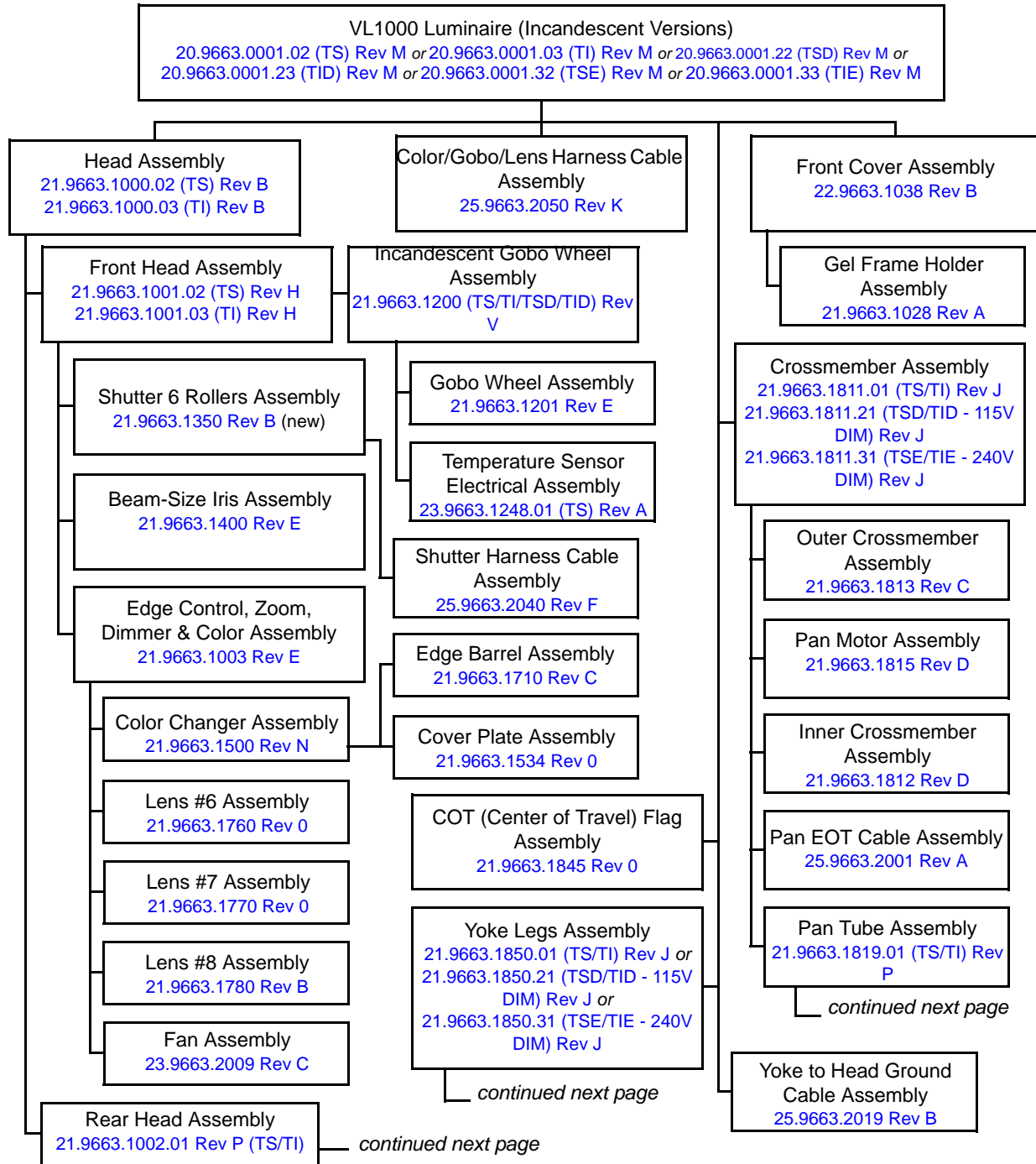

Figure 3-1: VL1000 Incandescent Luminaires Drawing Tree (Part 1)

VL1000 Incandescent Luminaires (continued)

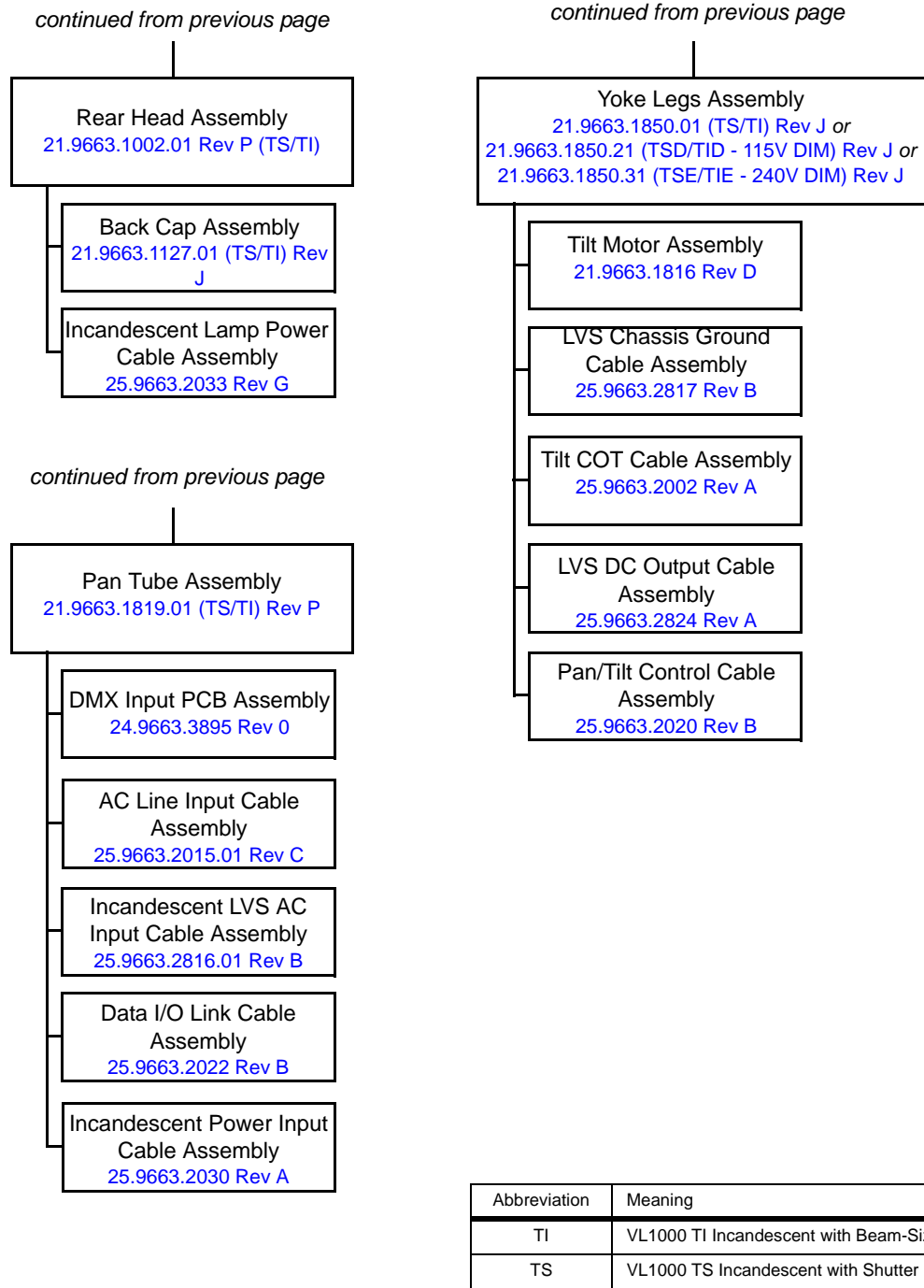

Figure 3-2: VL1000 Incandescent Luminaires Drawing Tree (Part 2)

VL1000 Arc Luminaires

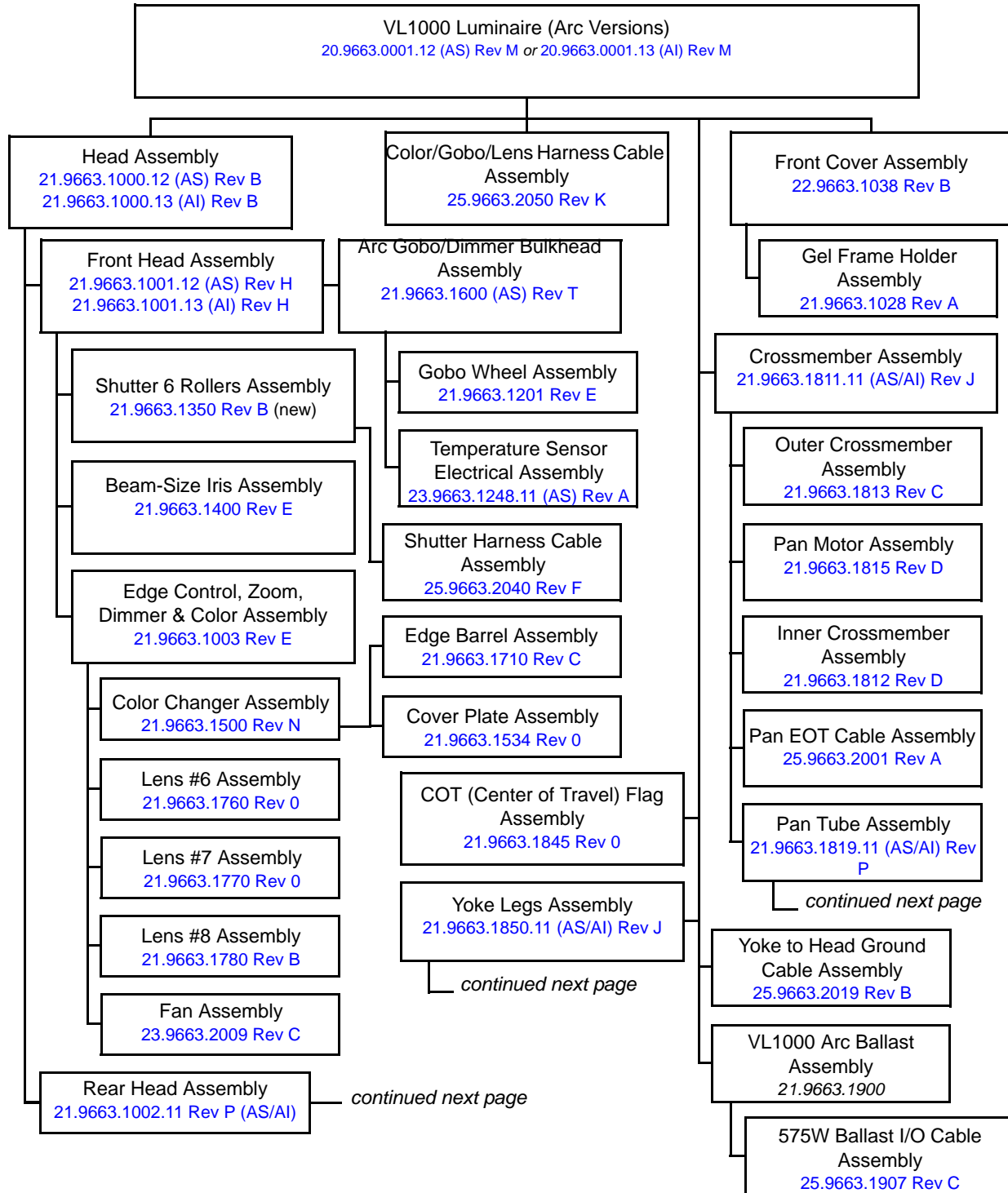
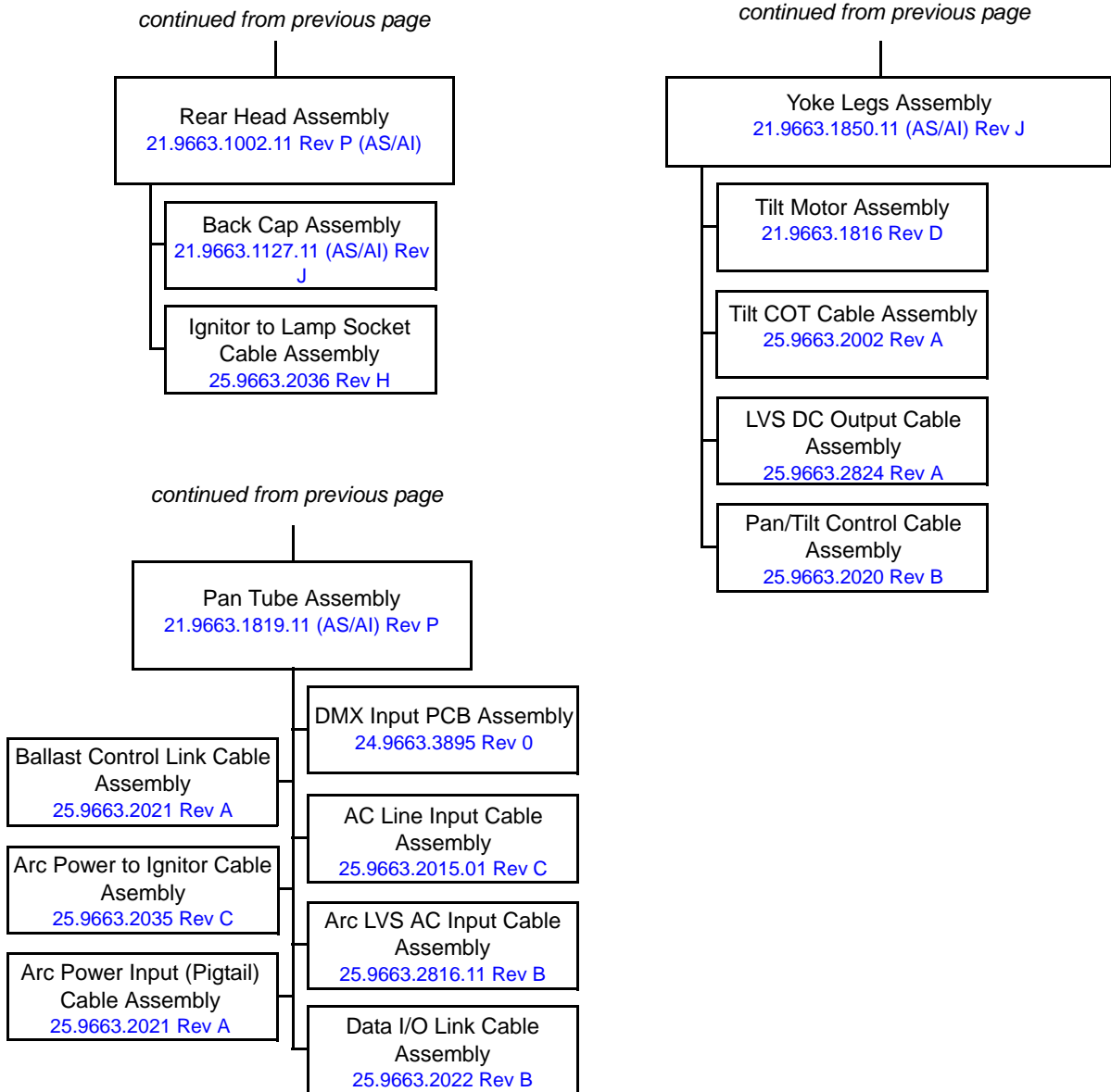

Figure 3-3: VL1000 Arc Luminaires Drawing Tree (Part 1)

VL1000 Arc Luminaires (continued)



Abbreviation	Meaning
AI	VL1000 AI Arc with Beam-Size Iris
AS	VL1000 AS Arc with Shutter System

Figure 3-4: VL1000 Incandescent Luminaires Drawing Tree (Part 2)

Top Assembly

Included Items Kit

28.9663.0001 Rev J

Refer to [Figure 3-5](#).

No.	Item	Qty.	UM.	Description
1	02.8001.0001	1	EA	PRODUCT SUPPORT SHEET, VARI-LITE CUSTOMER SERVICE
2	02.8052.0001	1	EA	CARD, LIMITED WARRANTY 09-09-02
3	02.8700.0001	1	EA	CARD, PRODUCT REGISTRATION - VL2000
4	02.9663.0002	1	EA	UNPACK/QUICK START SHEET, VL1000
5	07.9663.0032	1	EA	SHIPPING BOX, CARDBOARD - VL1000 (changed 03-05-04)
6	08.1000.0001	1	EA	CD ROM, VL1000 PRODUCT, DOCUMENTATION
7	52.6541.0001	1	EA	CONN, BLUE CABLE PWR INLET 3-POLE LOCKING - POWERCON
-	52.6541.0002	1	EA	CONN, WHITE CABLE PWR INLET (240V W/ INTG DIMMER ONLY - NOT SHOWN)
8	53.6505.0027	1	EA	BOLT, 1/2" X 13 X 1" LG HX HD ZINC (AS/AI ONLY)
-	53.6523.0013	8	EA	SCREW, 6-32 X 3/8" PTB (NOT SHOWN)
9	55.6539.0001	1	EA	WASHER, 1/2" SPLIT LOCK (AS/AI ONLY)
10	71.2554.0115	1	EA	1000 WATT INCANDESCENT LAMP, 115 VAC (TS/TI ONLY)
	71.2554.0240	1	EA	1000 WATT INCANDESCENT LAMP, 240 VAC (TS/TI ONLY)
	71.2528.0575	1	EA	575 WATT ARC LAMP (AS/AI ONLY)

Included Items Kit (continued)

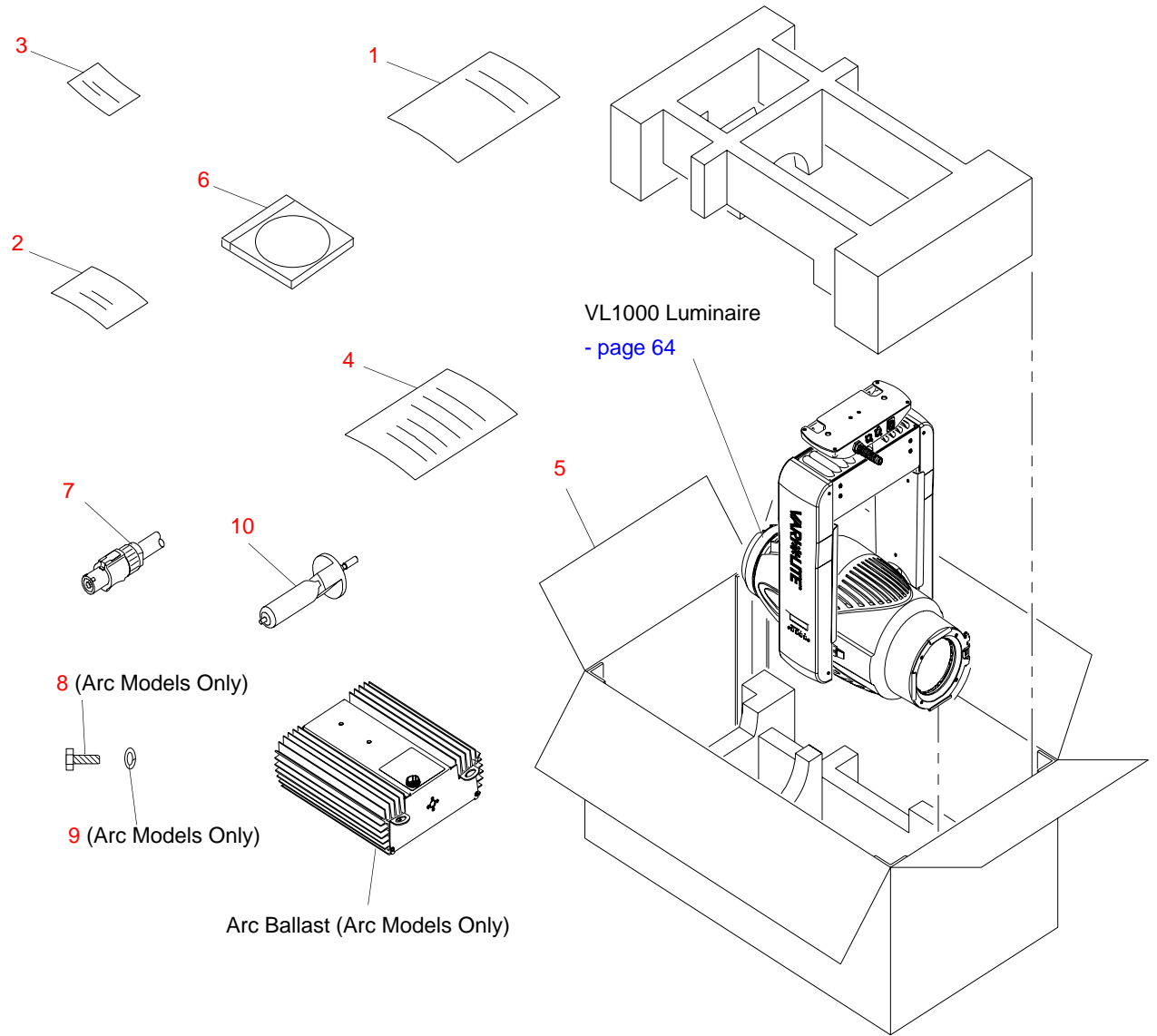

Figure 3-5: Included Items

Label Locations

Rev D

Refer to [Figure 3-6](#).

No.	Item	Qty.	UM.	Description
1	04.9661.0033.01	1	EA	LABEL, WARNING -2000 SERIES
2	04.9661.0034	1	EA	LABEL, RELAMPING -2000 SERIES
3	04.9661.0037	1	EA	LABEL, 625W ARC -2400 SERIES (AI/AS ONLY)
4	04.9663.1837	1	EA	LABEL, PATENT
5	04.9663.1860	1	EA	LABEL, 1000 SERIES COMPLIANCE
6	04.9663.1862	1	EA	LABEL, AC INPUT RATING LABEL MODEL VL1000TS
	04.9663.1864	1	EA	LABEL, AC INPUT RATING LABEL MODEL VL1000AS
	04.9663.1873	1	EA	LABEL, AC INPUT RATING LABEL MODEL VL1000TI
	04.9663.1874	1	EA	LABEL, AC INPUT RATING LABEL MODEL VL1000AI
7	04.9663.1881	2	EA	LABEL, AC INPUT RATING LABEL MODEL VL1000TXD
	04.9663.1882	2	EA	LABEL, AC INPUT RATING LABEL MODEL VL1000TSD
	04.9663.1883	2	EA	LABEL, AC INPUT RATING LABEL MODEL VL1000TID
	04.9663.1884	2	EA	LABEL, AC INPUT RATING LABEL MODEL VL1000TXD230
	04.9663.1885	2	EA	LABEL, AC INPUT RATING LABEL MODEL VL1000TSD230
	04.9663.1886	2	EA	LABEL, AC INPUT RATING LABEL MODEL VL1000TID230
8	04.9663.1865	1	EA	LABEL, 1000 SERIES INCANDESCENT (TI/TS ONLY)
9	04.9663.1920	1	EA	LABEL, PRODUCT VL1000APS (AI/AS ONLY - NOT SHOWN)

Label Locations (continued)

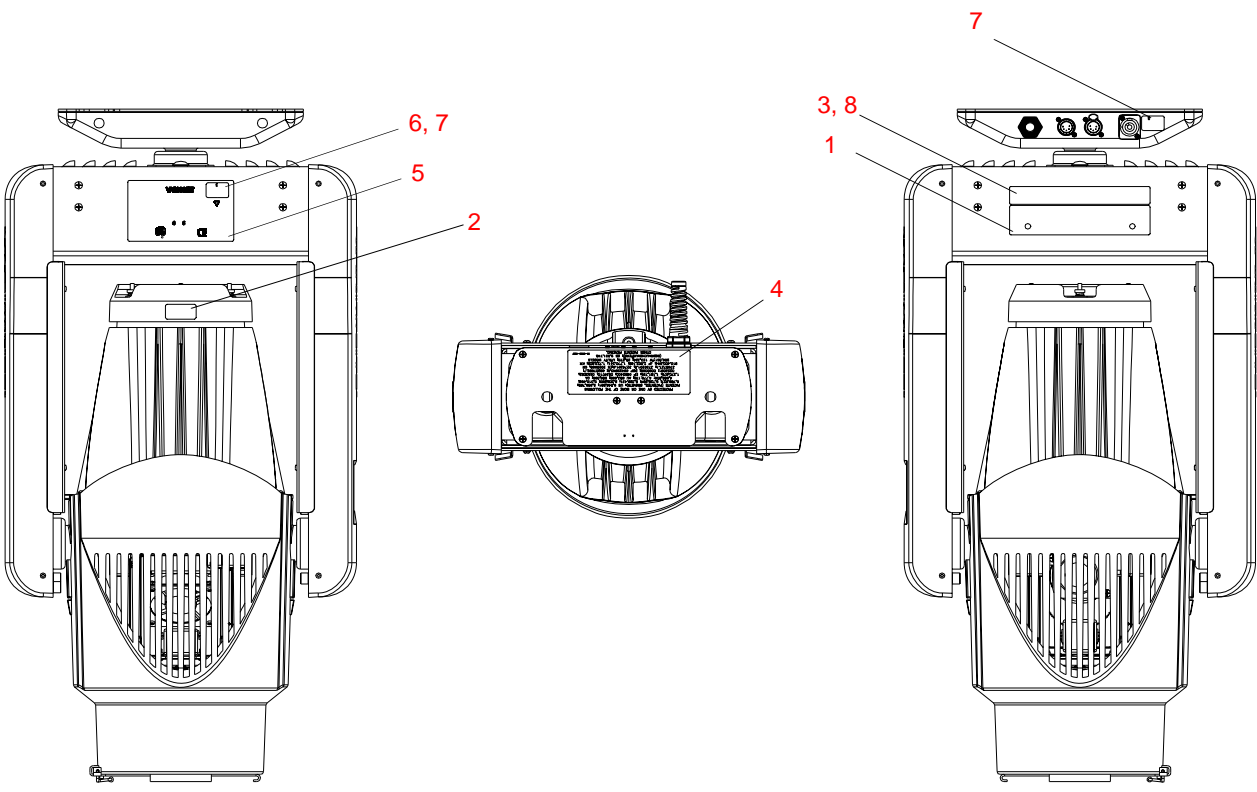

Figure 3-6: Label Locations

VL1000 Luminaire

20.9663.0001.02 (TS) Rev M
 20.9663.0001.03 (TI) Rev M
 20.9663.0001.12 (AS) Rev M
 20.9663.0001.13 (AI) Rev M
 20.9663.0001.22 (TSD) Rev M
 20.9663.0001.23 (TID) Rev M
 20.9663.0001.32 (TSE) Rev M
 20.9663.0001.33 (TIE) Rev M

Refer to [Figure 3-7](#)

No.	Item	Qty.	UM.	Description
1	10.9663.1823	1	EA	PULLEY, TILT
2	10.9663.1824	1	EA	SPACER, TILT TUBE
3	10.9663.1831	1	EA	PLATE, YOKE ARM DISPLAY
4	10.9663.1832	1	EA	OVERLAY, DISPLAY
5	10.9663.1835	1	EA	COVER, YOKE ARM DISPLAY SIDE
6	10.9663.1836	1	EA	COVER, YOKE ARM NO DISPLAY (TS/TI/AS/AI ONLY)
7	10.9663.1874	1	EA	COVER, YOKE ARM DIM SIDE (TSD/TID/TSE/TIE ONLY)
8	21.9663.1000.02	1	EA	ASSY, HEAD W/ SHUTTER (TS/TSD/TSE ONLY)
	21.9663.1000.03	1	EA	ASSY, HEAD W/ IRIS (TI/TID/TIE ONLY)
	21.9663.1000.12	1	EA	ASSY, HEAD ARC, W/ SHUTTER (AS ONLY)
	21.9663.1000.13	1	EA	ASSY, HEAD ARC W/ IRIS (AI ONLY)
9	21.9663.1811.01	1	EA	ASSY, CROSSMEMBER (TI/TS ONLY)
	21.9663.1811.11	1	EA	ASSY, CROSSMEMBER (AI/AS ONLY)
	21.9663.1811.21	1	EA	ASSY, CROSSMEMBER, 115V DIMMER (TSD/TID ONLY)
	21.9663.1811.31	1	EA	ASSY, CROSSMEMBER, 230V DIMMER (TSE/TIE ONLY)
10	21.9663.1845	1	EA	ASSY, COT FLAG
11	21.9663.1850.01	1	EA	ASSY, YOKE LEGS (TI/TS ONLY)
	21.9663.1850.11	1	EA	ASSY, YOKE LEGS (AI/AS ONLY)
	21.9663.1850.21	1	EA	ASSY, YOKE LEGS W/ 115V DIMMER (TSD/TID ONLY)
	21.9663.1850.31	1	EA	ASSY, YOKE LEGS W/ 230V DIMMER (TSE/TIE ONLY)
12	22.9663.1038	1	EA	ASSY, FRONT COVER
13	24.9663.3930	1	EA	PCB ASSY, VL1000 CONTROLLER
-	25.9663.2019	1	EA	CABLE ASSY, YOKE TO HEAD GROUND - NOT SHOWN
-	25.9663.2036	1	EA	CABLE ASSY, IGNITOR TO LAMP (AI/AS ONLY)- NOT SHOWN
-	25.9663.2050	1	EA	CABLE ASSY, COLOR/GOBO/LENS HARNESS - NOT SHOWN
14	53.2019.0004	4	EA	NUT, 3/8-16 X 7/32"THK HEX JAM GRD5 ZINC PLT

No.	Item	Qty.	UM.	Description
15	53.6517.0001	3	EA	SCREW, 10-32 X 3/8"LG PPZ
16	53.6543.0001	4	EA	SCREW, 6-32 X 3/8" PPB
17	53.6614.0001	3	EA	SCREW, 6-32 X 5/8" PPB
18	53.6627.0001	12	EA	SCREW, 10-32 X 5/8" PPB
19	53.6634.0003	4	EA	SCREW, 3/8-16 X 1/2"LG SOC HD CAP ALLY STL
20	53.6642.0001	3	EA	SCREW, 10-32 X 5/8" SLF TAP TYPE F PPZ
21	54.1255.0001	2	EA	BEARING ASSY, BLACK FLUSH MOUNT HOUSING
22	54.2047.0039	1	EA	BELT, TIMING GT 3MM PITCH 350GRV 6MM WD NEOPRENE
23	55.2115.0001	4	EA	WASHER, 3/8 X .04 THK HEX JAM
24	53.6523.0013	8	EA	SCREW, 6-32 X 3/8" PTB
25	21.9663.1901	1	EA	BALLAST ASSEMBLY (AI/AS ONLY)
-	25.9663.1907	1	EA	CABLE ASSY, 575W BALLAST I/O (AI/AS ONLY)- NOT SHOWN

VL1000 Luminaire (continued)

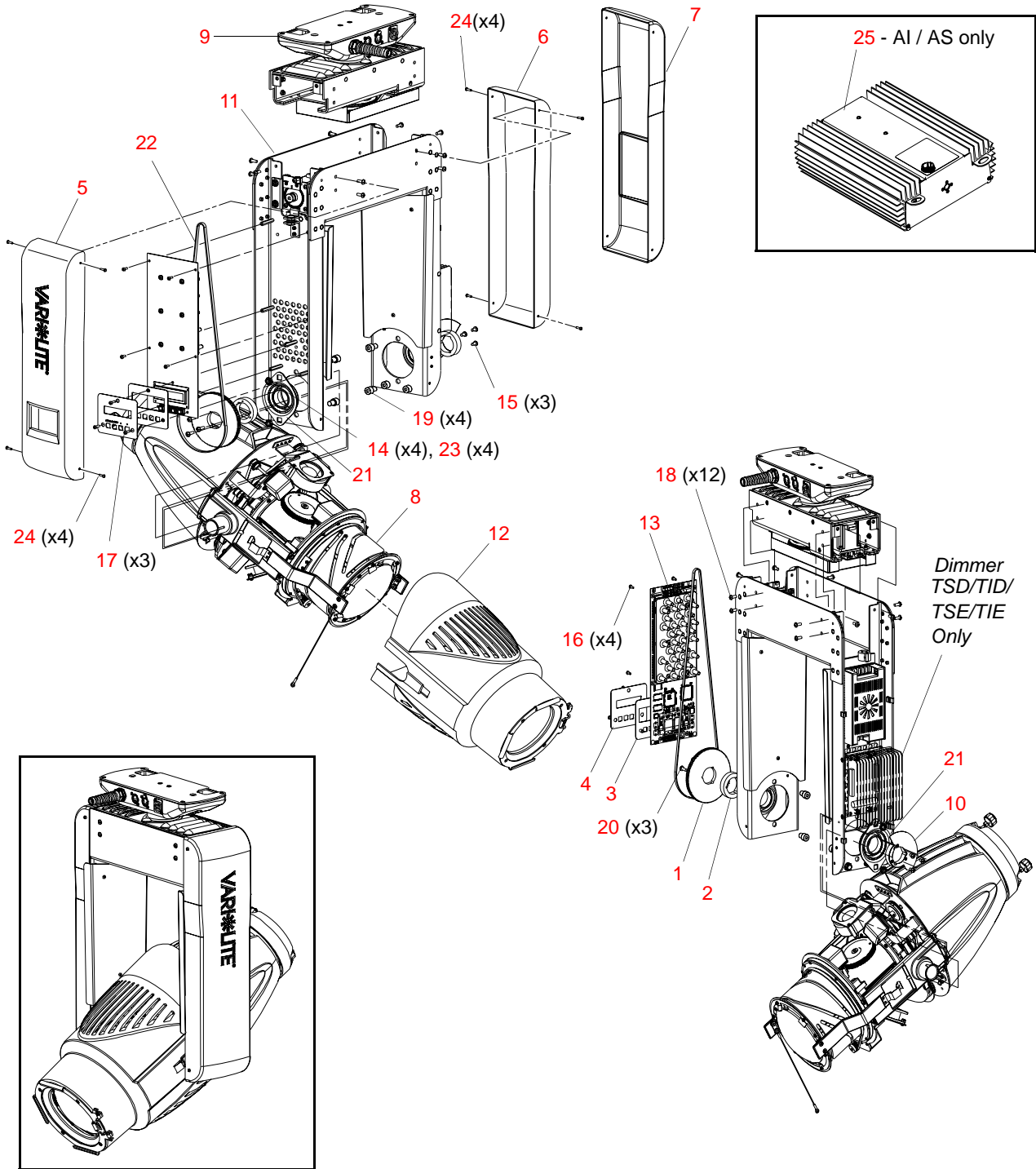

Figure 3-7: VL1000 Luminaire

Front Cover Assembly

22.9663.1038 Rev B

Refer to [Figure 3-8](#).

No.	Item	Qty.	UM.	Description
1	10.9663.1020	1	EA	COVER, FRONT VL1000
2	21.9663.1028	1	EA	ASSY, GEL FRAME HOLDER
3	53.2004.0002	4	EA	NUT, 8-32 KEPS, ZINC PLATE (changed 09-02-03)
4	53.6545.0007	3	EA	SCREW, 8-32 X 3/8" PFB
5	53.6552.0002	1	EA	SCREW, 8-32 X 1/2" PFB

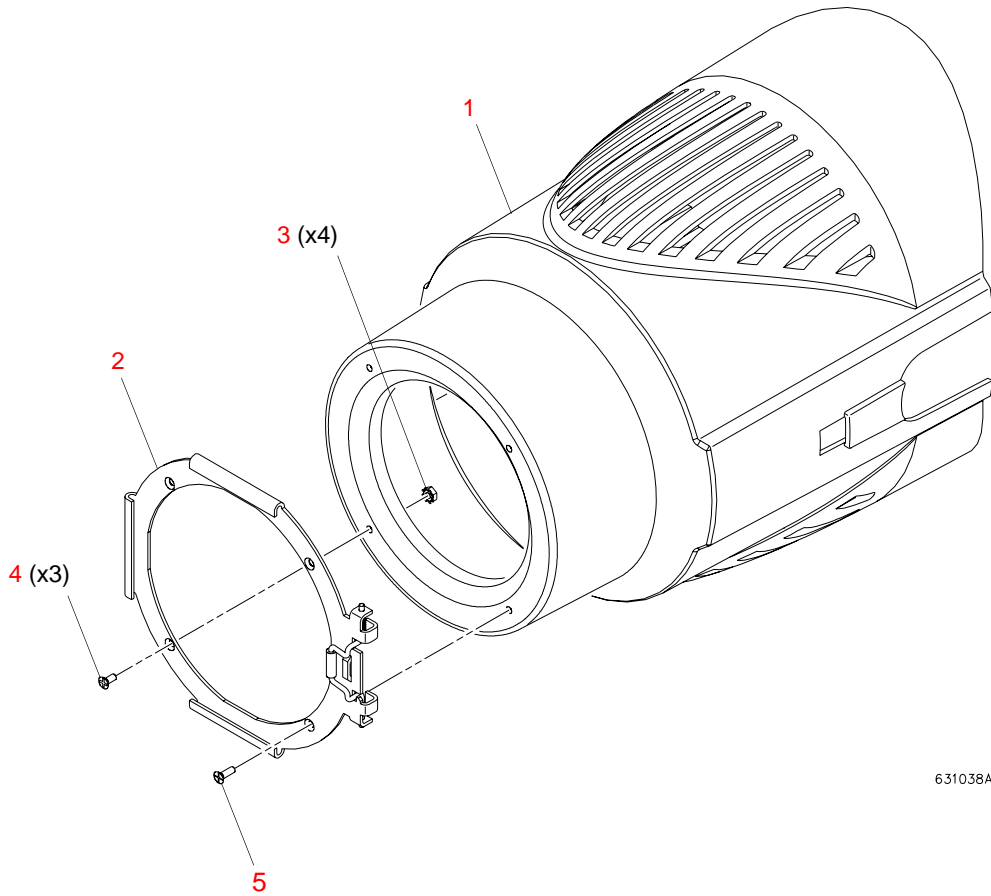

Figure 3-8: Front Cover Assembly

Gel Frame Holder Assembly

21.9663.1028 Rev A

Refer to [Figure 3-9](#).

No.	Item	Qty.	UM.	Description
1	10.9663.1027	1	EA	HOLDER, GEL FRAME
2	10.9663.1031	1	EA	LATCH, GEL FRAME
3	55.6568.0026	1	EA	SPRING, CPRSN .180"OD .810"LG .026" WIRE DIA SS
4	55.6738.0003	.06	FT	TUBING, SILICONE RUBBER 1/8"ID X 1/4"OD TRANSLUCENT

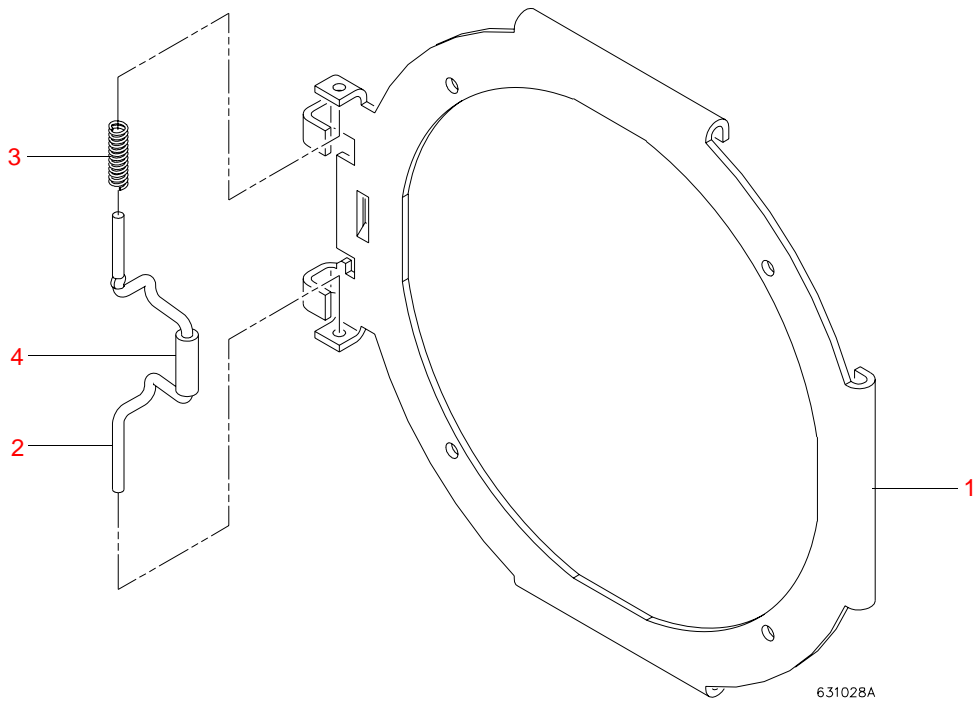

Figure 3-9: Gel Frame Holder Assembly

COT (Center of Travel) Flag Assembly

21.9663.1845 Rev 0

Refer to [Figure 3-10](#).

No.	Item	Qty.	UM.	Description
1	10.9663.1824	1	EA	SPACER, TILT TUBE
2	10.9663.1826	1	EA	FLAG, CENTER OF TRAVEL -TILT
3	53.6602.0001	3	EA	SCREW, 4-40 X 1/4 " PPZ TYPE F

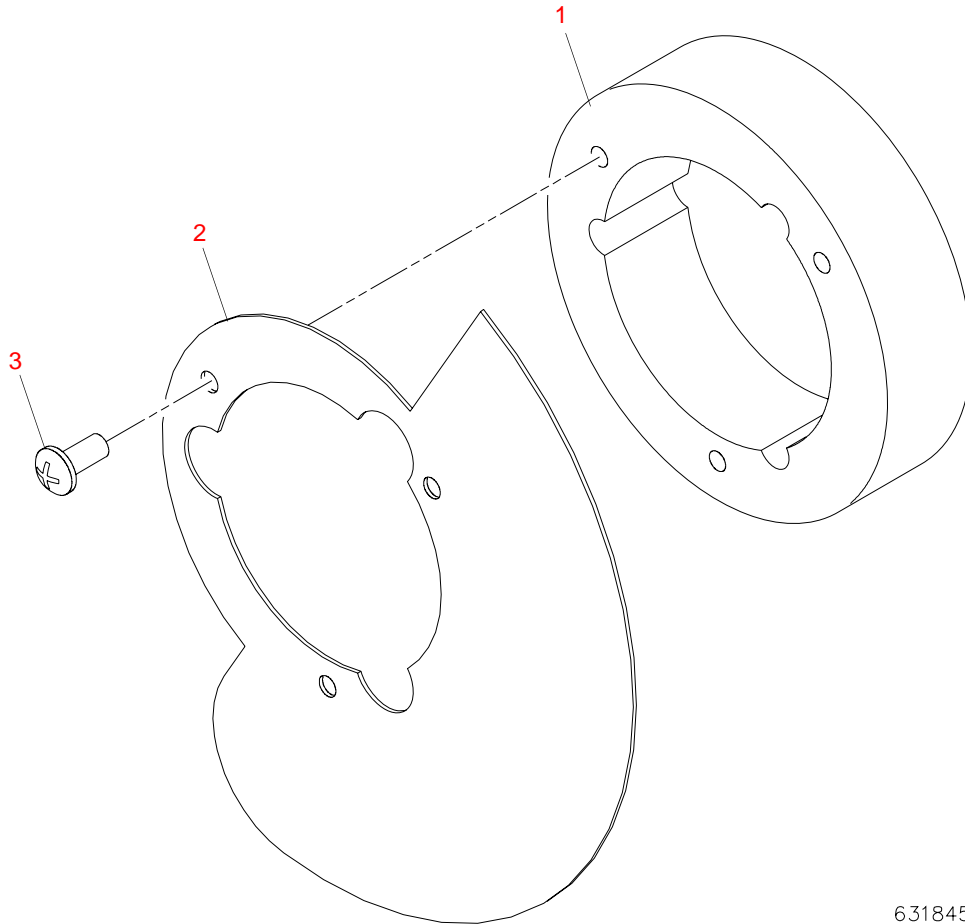

631845

Figure 3-10: COT Flag Assembly

Notes

Head Assembly

Head Assembly

21.9663.1000.02 (TS) Rev B
 21.9663.1000.03 (TI) Rev B
 21.9663.1000.12 (AS) Rev B
 21.9663.1000.13 (AI) Rev B

Refer to [Figure 3-11](#).

No.	Item	Qty.	UM.	Description
1	10.9663.1032	2	EA	SPACER, SIDE RAIL (TS ONLY)
		4	EA	SPACER, SIDE RAIL (AS ONLY)
2	21.9663.1001.02	1	EA	ASSY, FRONT HEAD (TS ONLY)
	21.9663.1001.03	1	EA	ASSY, FRONT HEAD (TI ONLY)
	21.9663.1001.12	1	EA	ASSY, FRONT HEAD (AS ONLY)
	21.9663.1001.13	1	EA	ASSY, FRONT HEAD (AI ONLY)
3	21.9663.1002.01	1	EA	ASSY, REAR HEAD (TS ONLY)
	21.9663.1002.11	1	EA	ASSY, REAR HEAD (AS ONLY)
4	53.6627.0001	4	EA	SCREW, 10-32 X 5/8" PPB
5	55.3303.0010	4	EA	WASHER, #10 .438"OD .040"THK SPLIT LOCK SS

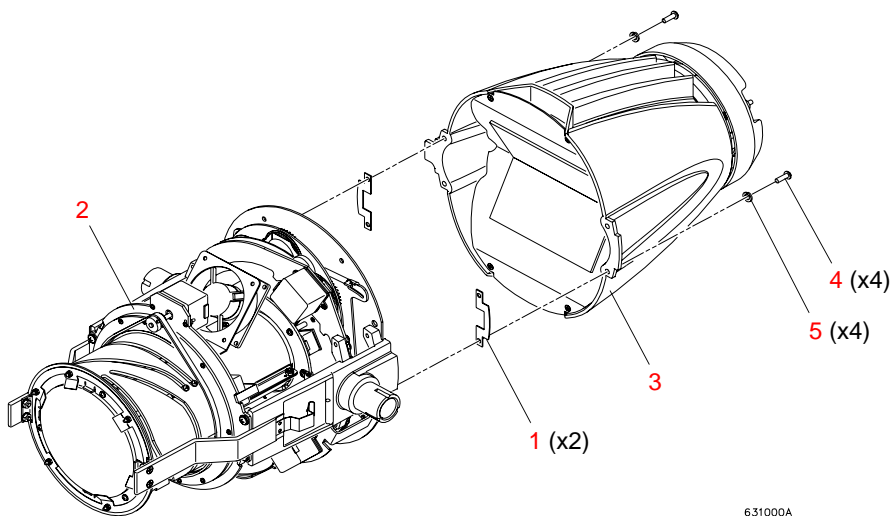

Figure 3-11: Head Assembly

Front Head Assembly

21.9663.1001.02 (TS) Rev H

21.9663.1001.03 (TI) Rev H

21.9663.1001.12 (AS) Rev H

21.9663.1001.13 (AI) Rev H

Refer to [Figure 3-12](#).

No.	Item	Qty.	UM.	Description
1	07.5049.0001	1	EA	LANYARD, NYLON COATED 8" LG
2	21.9663.1003	1	EA	ASSY, EDGE, ZOOM & COLOR
3	21.9663.1033	1	EA	ASSY, SIDE RAIL, PULLEY
4	21.9663.1034	1	EA	ASSY, SIDE RAIL, SENSOR
5	21.9663.1200	1	EA	ASSY, GOBO BULKHEAD, INCANDESCENT (TS ONLY)
	21.9663.1600	1	EA	ASSY, GOBO/DIMMER BULKHEAD, ARC (AS ONLY)
6	21.9663.1350	1	EA	ASSY, SHUTTER 6 ROLLERS (TS/AS ONLY) (NEW VERSION)
7	21.9663.1400	1	EA	ASSY, IRIS (TI/AI ONLY)
8	53.6552.0002	4	EA	SCREW, 8-32 X 1/2" PFB
9	53.2004.0002	4	EA	NUT, 8-32 KEPS ZINC PLATE
10	53.6627.0001	12	EA	SCREW, 10-32 X 5/8" PPB
11	55.2179.0006	3	EA	SADDLE WIRE BLIND HOLE .79" (added 12-09-02)
12	55.3303.0010	12	EA	WASHER, #10 .438"OD .040THK SPLIT LOCK SS

Front Head Assembly (continued)

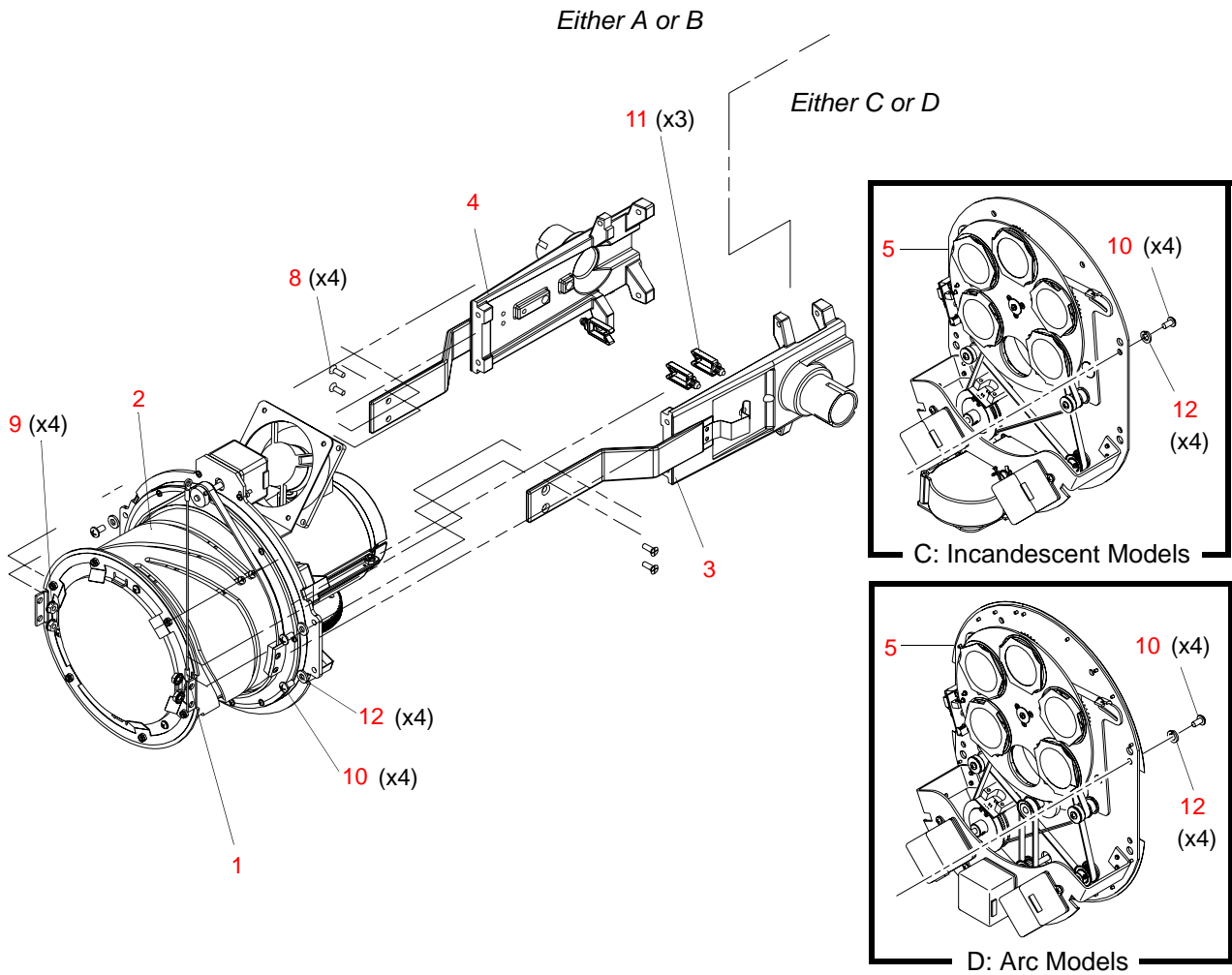
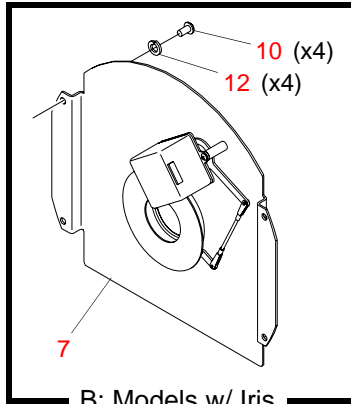
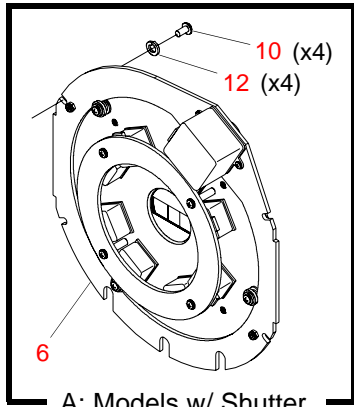

Figure 3-12: Front Head Assembly

Edge Control, Zoom, Dimmer & Color Assembly

21.9663.1003 Rev E

Refer to [Figure 3-13](#).

No.	Item	Qty.	UM.	Description
1	10.9663.1039	1	EA	SUPPORT, AXIAL FAN
2	10.9663.1755	3	EA	ROLLER, BARREL
3	10.9663.1756	6	EA	ROLLER, LENS
4	10.9663.1757	1	EA	CLAMP, BELT BASE
5	10.9663.1758	1	EA	BELT CLAMP
6	10.9663.1767	1	EA	ZOOM TEFLON SPACER
7	10.9663.1790	1	EA	BELT PULLEY, GT 3MM PITCH 16 GROOVES
8	12.9663.1754	1	EA	MACHINED EXTRUSION, OUTER BARREL ZOOM
9	21.9663.1500	1	EA	ASSY, COLOR CHANGER
10	21.9663.1760	1	EA	ASSY, LENS #6
11	21.9663.1770	1	EA	ASSY, LENS #7
12	21.9663.1780	1	EA	ASSY, LENS #8
13	23.9663.2009	1	EA	ASSY, FAN
14	44.9663.1766	1	EA	MOTOR, 17 1.24" SHAFT 11.8MH 5.5 OHM
15	53.2003.0001	2	EA	NUT, 4-40 KEP ZINC PLATED
16	53.2202.0006	4	EA	NUT, 6-32 HEX SS NYLON INSERT
17	53.5506.0750	6	EA	SCREW, 6-32 X 3/4 " PPSS
18	55.5559.0250	2	EA	SCREW, 6-32 X 1/4" SET CONE (added 08-28-03)
19	53.5604.0437	2	EA	SCREW, 4-40 X 7/16"LG PPSS BLACK
20	53.5606.0375	7	EA	SCREW, 6-32 X 3/8 " PPSS BLACK
21	53.6558.0003	2	EA	SCREW, 6-32 X 3/8" PPZ PLASTIC THREAD ROLLING
22	53.6567.0001	2	EA	SCREW, 4-40 X 1/2" PPZ
23	54.2048.0002	1	EA	BELT, TIMING HTD 3MMPITCH 195 GROOVE 6MMWIDE
24	55.3301.0006	2	EA	WASHER, #6 FLAT SS
25	55.3303.0006	3	EA	WASHER, #6 LOCK INT. TOOTH SS
26	55.6588.0003	3	EA	SPACER, 1/4"RND #6 THRU 1/8"LG .140"ID ZINC PLT BRS

Edge Control, Dimmer & Color Assembly (continued)

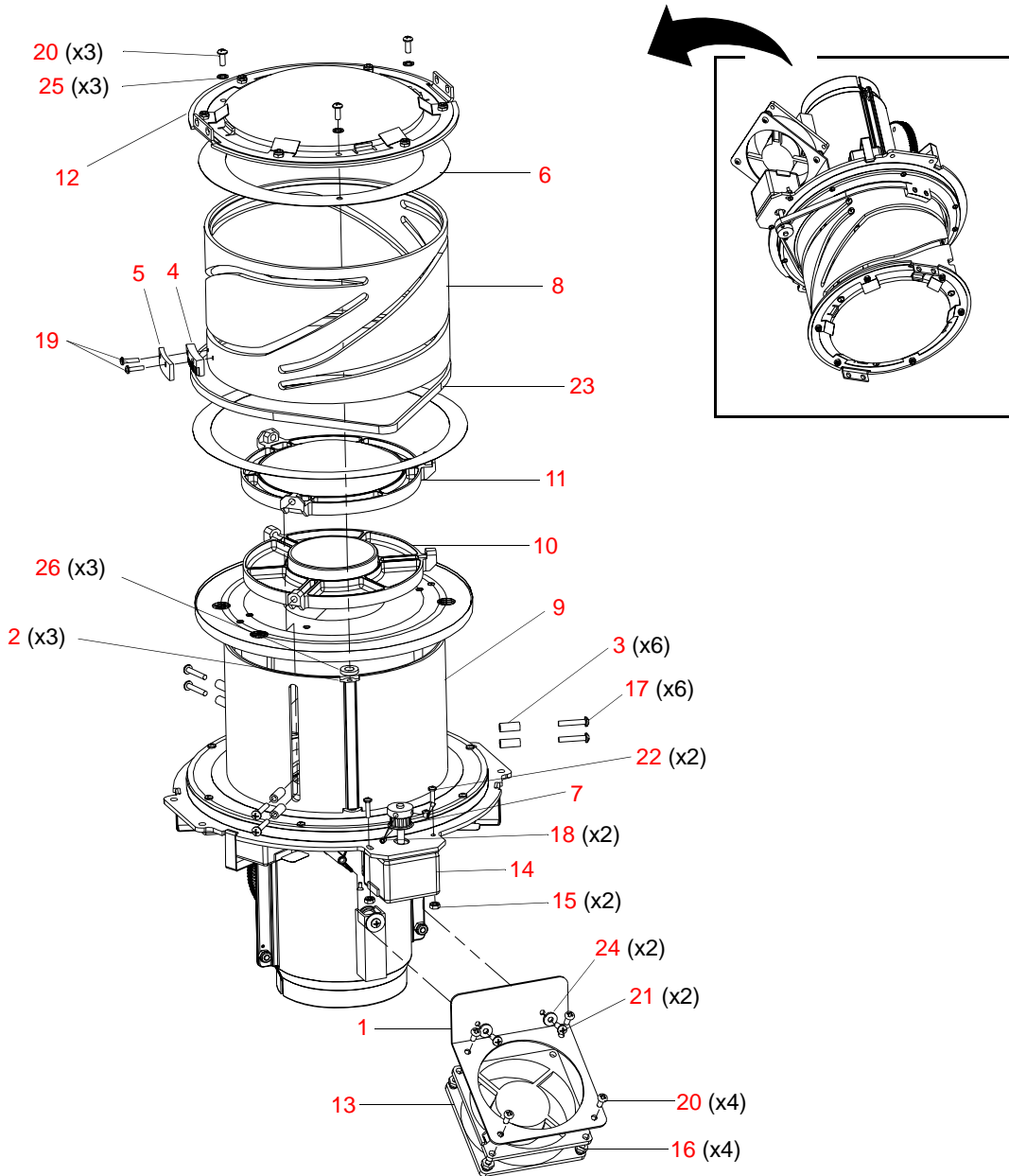

Figure 3-13: Edge Control, Dimmer & Color Assembly

Color Changer Assembly

21.9663.1500 Rev N

Refer to [Figure 3-14](#).

No.	Item	Qty.	UM.	Description
1	04.9663.1524	1	EA	LABEL, MAGENTA MOTOR
2	04.9663.1525	1	EA	LABEL, BLUE MOTOR
3	04.9663.1526	1	EA	LABEL, AMBER MOTOR
4	04.9663.1527	1	EA	LABEL, DIFFUSER MOTOR
5	10.9663.1505	4	EA	DRIVE RING
6	10.9663.1506	1	EA	DIFFUSER COVER PLATE
7	10.9663.1507	2	EA	COLOR SEPERATOR
8	10.9663.1508	1	EA	MOTOR MOUNT PLATE
9	10.9663.1509	1	EA	COLOR COVER PLATE, LINER SHEET
-	10.9663.1510	1	EA	DIFFUSER COVER PLATE LINER SHEET (NOT SHOWN)
10	10.9663.1511	3	EA	COLOR SPACER 1
11	12.9663.1512	1	EA	DRIVE RING LOCATOR, MACHINED
12	10.9663.1514	3	EA	COLOR SPACER 2
13	10.9663.1515	1	EA	DIFFUSER SPACER 1
14	10.9663.1516	1	EA	DIFFUSER SPACER 2
15	10.9663.1518	4	EA	COLOR MOTOR MOUNT CLIP
16	10.9663.1521	1	EA	COLOR COVER PLATE, LINER SHEET
17	10.9663.1522	1	EA	DIFFUSER COVER PLATE, LINER SHEET
18	10.9663.1532	2	EA	RING SPACER
19	10.9663.1755	3	EA	ROLLER, BARREL
20	10.9663.1767	1	EA	ZOOM TEFLON SPACER
21	12.9663.1752	1	EA	MACHINED EXTRUSION, INNER BARREL ZOOM
22	44.9663.1539	4	EA	MOTOR SIZE 14, 10.8MH, 10.1 OHM WITH SPUR GEAR
23	21.9663.1534	1	EA	ASSY, COVER PLATE
24	21.9663.1538.01	2	EA	ASSY, MAGENTA COLOR FILTER
25	21.9663.1538.02	2	EA	ASSY, BLUE COLOR FILTER
26	21.9663.1538.03	2	EA	ASSY, AMBER COLOR FILTER
27	21.9663.1538.04	2	EA	ASSY, DIFFUSER GLASS RIGHT
28	21.9663.1710	1	EA	ASSY, BARREL
29	53.2002.0003	4	EA	NUT, 6-32 HEX ZINC NYLON INSERT

No.	Item	Qty.	UM.	Description
30	53.2200.0004	8	EA	NUT, 4-40 KEPS SS
31	53.5636.0375	3	EA	SCREW, 6-32 X 3/8 " PFSS BLACK
32	53.6556.0001	8	EA	SCREW, 4-40 X 3/4"LG PPZ
33	55.6588.0003	3	EA	SPACER, 1/4"RND #6 THRU 1/8"LG .140"ID ZINC PLT BRS
34	10.9663.1537	1	EA	DRIVE RING LOCATOR BEARING

Color Changer Assembly (continued)

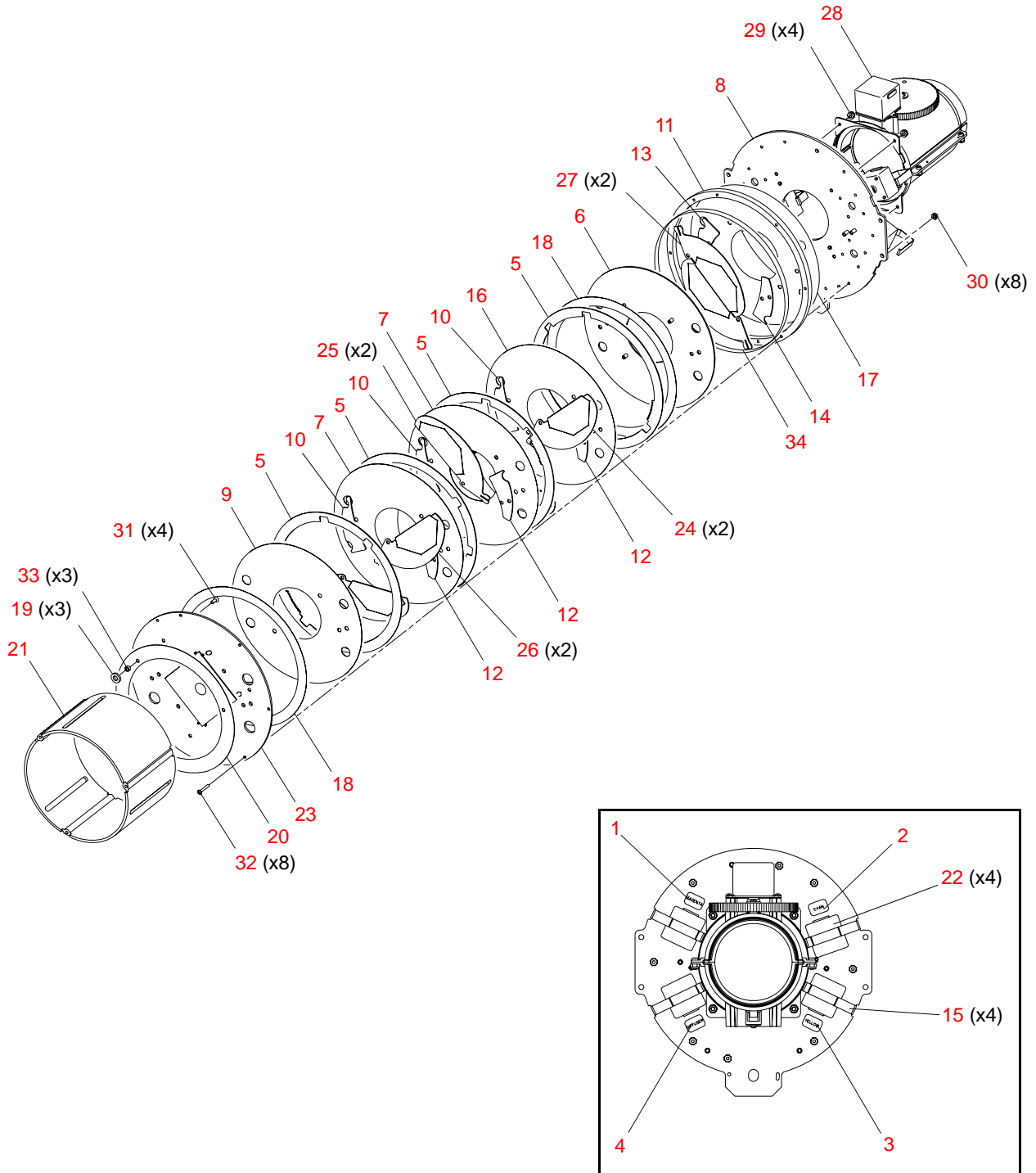

Figure 3-14: Color Changer Assembly

Cover Plate Assembly

21.9663.1534 Rev 0

Refer to [Figure 3-15](#).

No.	Item	Qty.	UM.	Description
1	10.9663.1517	1	EA	COVER PLATE, COLOR CHANGER
2	10.9663.1535	1	EA	DISC, .63 DIA ALUM
3	41.9663.1530	1	EA	GLASS, BEAM OCCLUSION
4	53.6659.0008	4	EA	SCREW, 2-56 X 3/16" PFZ

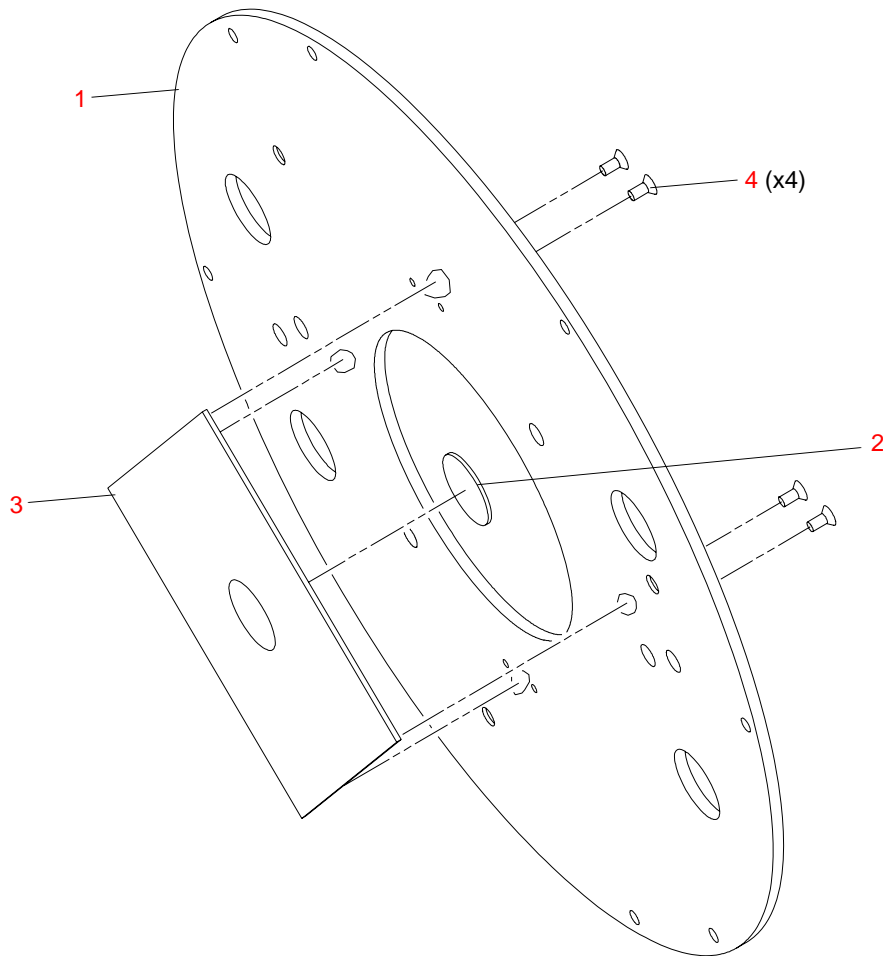

Figure 3-15: Cover Plate Assembly

Edge Barrel Assembly

21.9663.1710 Rev C

Refer to [Figure 3-16](#).

No.	Item	Qty.	UM.	Description
1	10.9663.1701	2	EA	BARREL, HALF OUTER LENS EDGE SYSTEM
2	10.9663.1708	1	EA	EDGE GEAR/CAM, 8 ELEMENT SYSTEM
3	10.9663.1711	2	EA	BARREL, HALF INNER LENS EDGE SYSTEM
4	10.9663.1737	1	EA	EDGE, LIGHT BAFFLE
5	21.9663.1722	1	EA	ASSY, EDGE MOTOR
6	42.9663.1728	1	EA	LENS #1
7	42.9663.1731	1	EA	LENS #4
8	42.9663.1732	1	EA	LENS #5
9	42.9663.1736	1	EA	ASSY, LENS #2 & #3
10	53.2202.0006	4	EA	NUT, 6-32 HEX SS NYLON INSERT
11	53.6558.0001	4	EA	SCREW, 6-32 X 3/8" PPZ
12	53.6558.0003	4	EA	SCREW, 6-32 X 3/8" PPZ PLASTIC THREAD ROLLING
13	55.2123.0012	1	EA	WASHER, WAVE SPRING .484"OD .397"ID .009"THK CSTL
14	55.6636.0003	2	EA	WASHER, .562"OD .156"ID .046"THK #6 FLAT ZINC PLT

Barrel Assembly (continued)

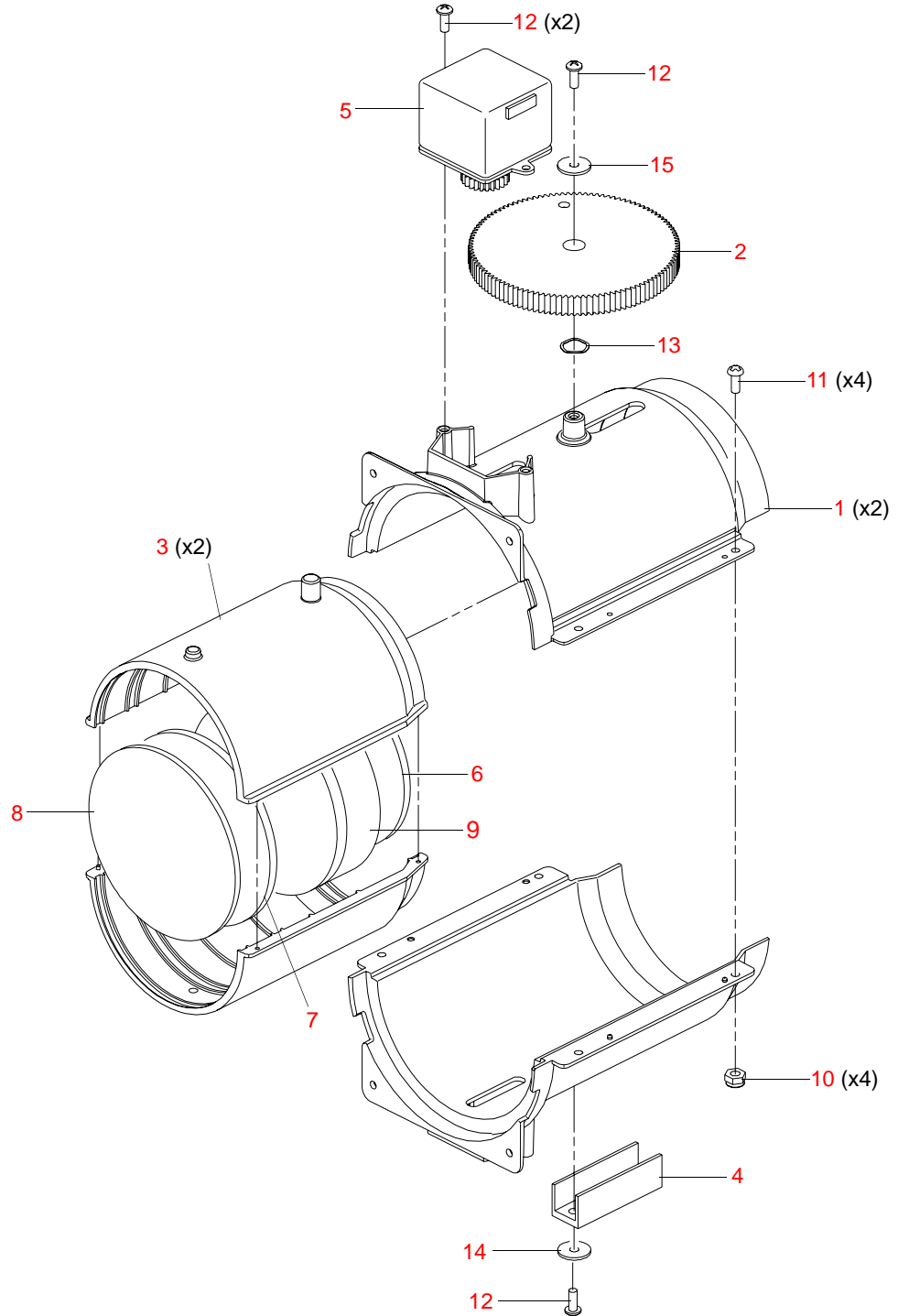

Figure 3-16: Edge Barrel Assembly

Lens #6 Assembly

21.9663.1760 Rev 0

Refer to [Figure 3-17](#).

No.	Item	Qty.	UM.	Description
1	10.9663.1761	1	EA	LENS CARRIER, MOLDED -LENS #6 ASSY
2	42.9663.1733	1	EA	LENS #6

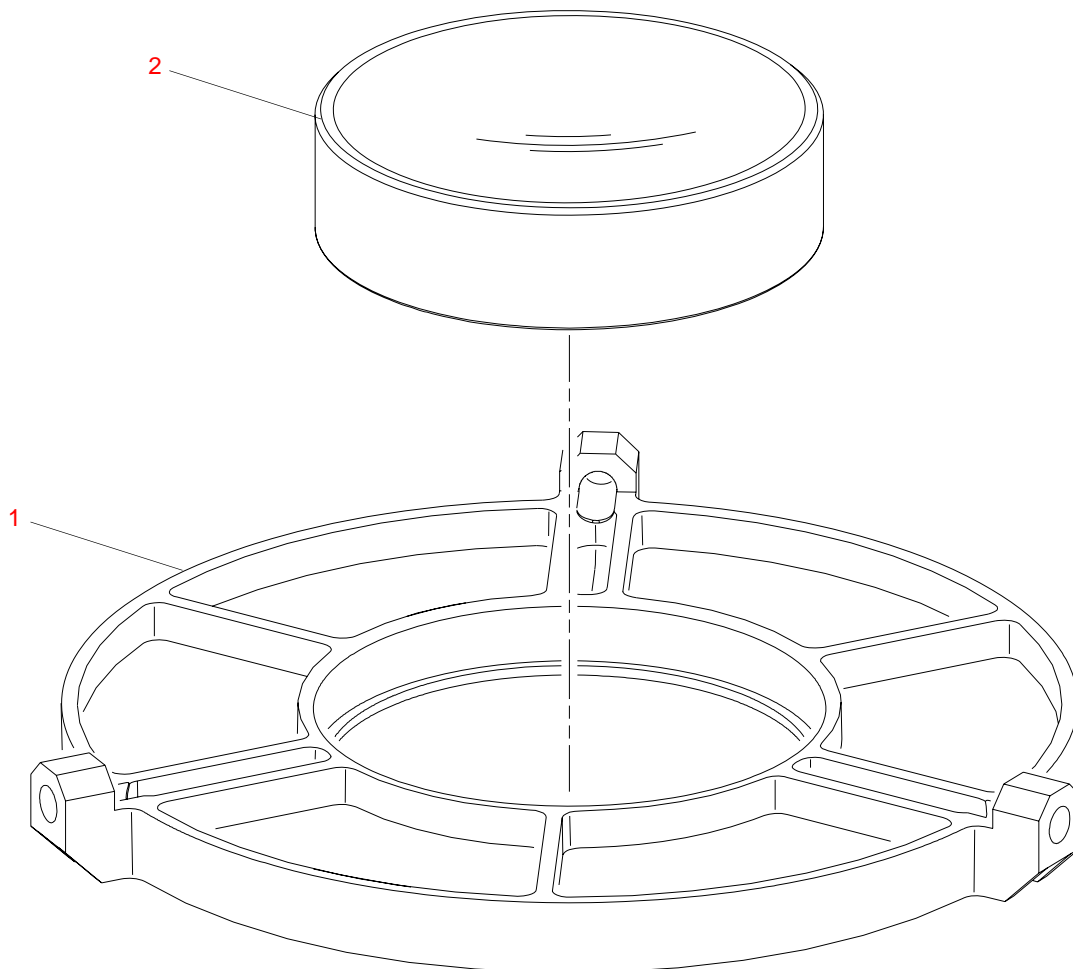

Figure 3-17: Lens #6 Assembly

Lens #7 Assembly

21.9663.1770 Rev 0

Refer to [Figure 3-18](#).

No.	Item	Qty.	UM.	Description
1	10.9663.1771	1	EA	LENS CARRIER, MOLDED -LENS #7
2	42.9663.1734	1	EA	LENS #7

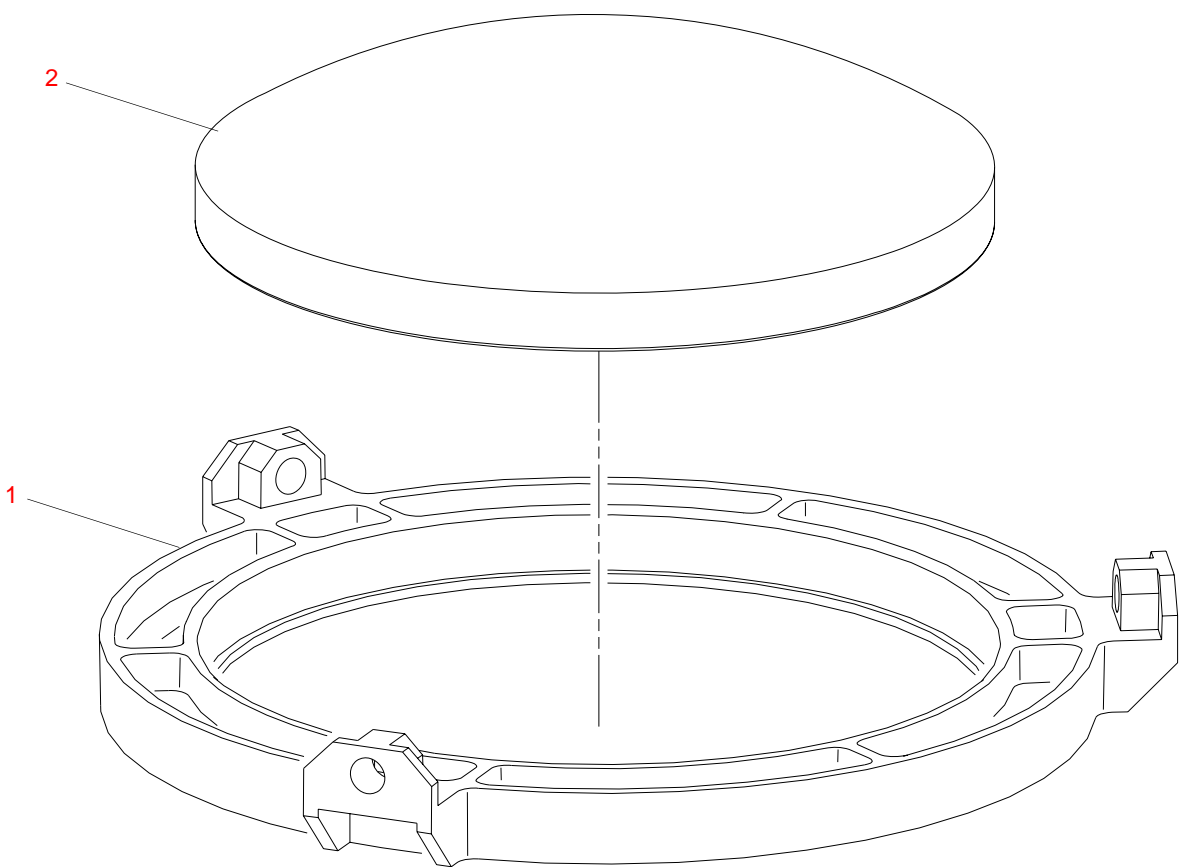

Figure 3-18: Lens #7 Assembly

Lens #8 Assembly

21.9663.1780 Rev B

Refer to [Figure 3-19](#).

No.	Item	Qty.	UM.	Description
1	10.9663.1782	1	EA	RING, RETAINING FRONT LENS
2	10.9663.1781	1	EA	BULKHEAD, FRONT -LENS #8 ASSY
3	42.9663.1735	1	EA	LENS #8
4	53.2202.0004	6	EA	NUT, 4-40 HEX SS NYLON INSERT
5	53.6559.0001	6	EA	SCREW, 4-40 X 1/4" PFZ

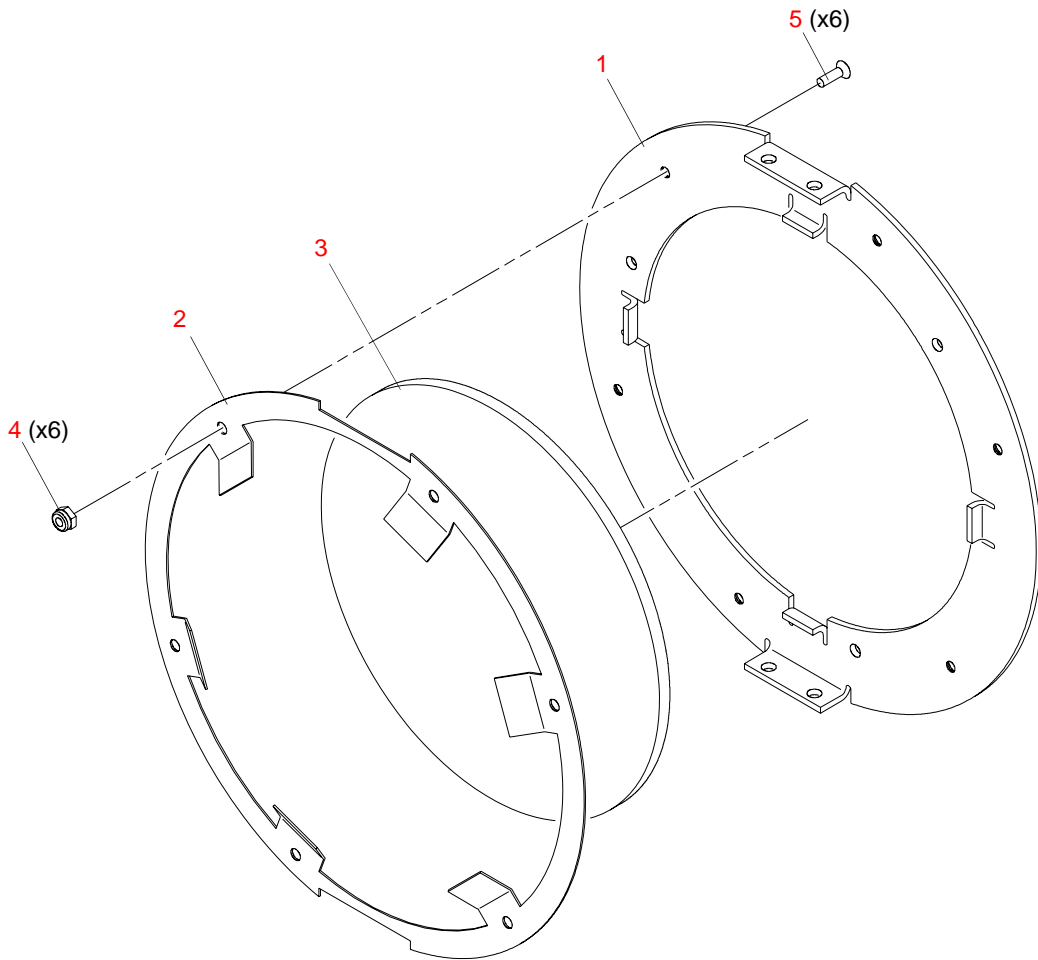

Figure 3-19: Lens #8 Assembly

Fan Assembly

23.9663.2009 Rev C

Refer to [Figure 3-20](#).

No.	Item	Qty.	UM.	Description
1	40.7113.0003	1	EA	FAN, +24V 80X80X25MM 24LFM
2	52.6523.0002	1	EA	CONN, HOUSING 2POS PLUG SHROUDED WIRE TO WIRE
3	52.8347.0001	2	EA	CONTACT, 24-30AWG MALE CRIMP

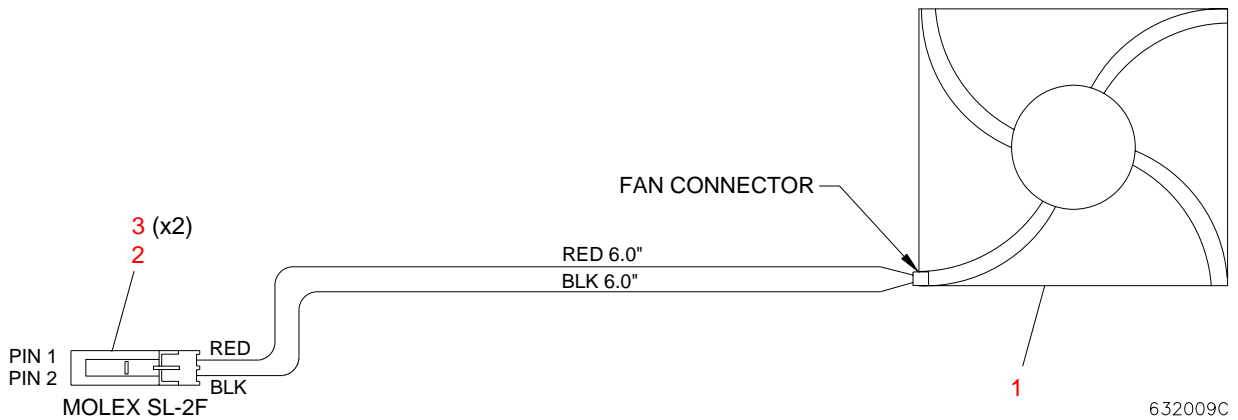

Figure 3-20: Fan Assembly

Pulley Side Rail Assembly

21.9663.1033 Rev B

Refer to [Figure 3-21](#).

No.	Item	Qty.	UM.	Description
1	10.9663.1026	1	EA	LATCH, SPRING
2	12.9663.1025	1	EA	RAIL, SIDE MACHINED LONG TILT TUBE
3	53.2002.0004	1	EA	NUT, 6-32 ACORN THREAD LOCKING SS
4	53.5636.0500	1	EA	SCREW, 6-32 X 1/2" PFSS BLACK
5	53.6530.0009	2	EA	RIVET, 1/8"OD POP .126-.187GL STL BODY STL MNDRL DOME
6	55.2178.0002	1	EA	CABLE ANCHOR MOUNT, #10 SCREW MOUNTING

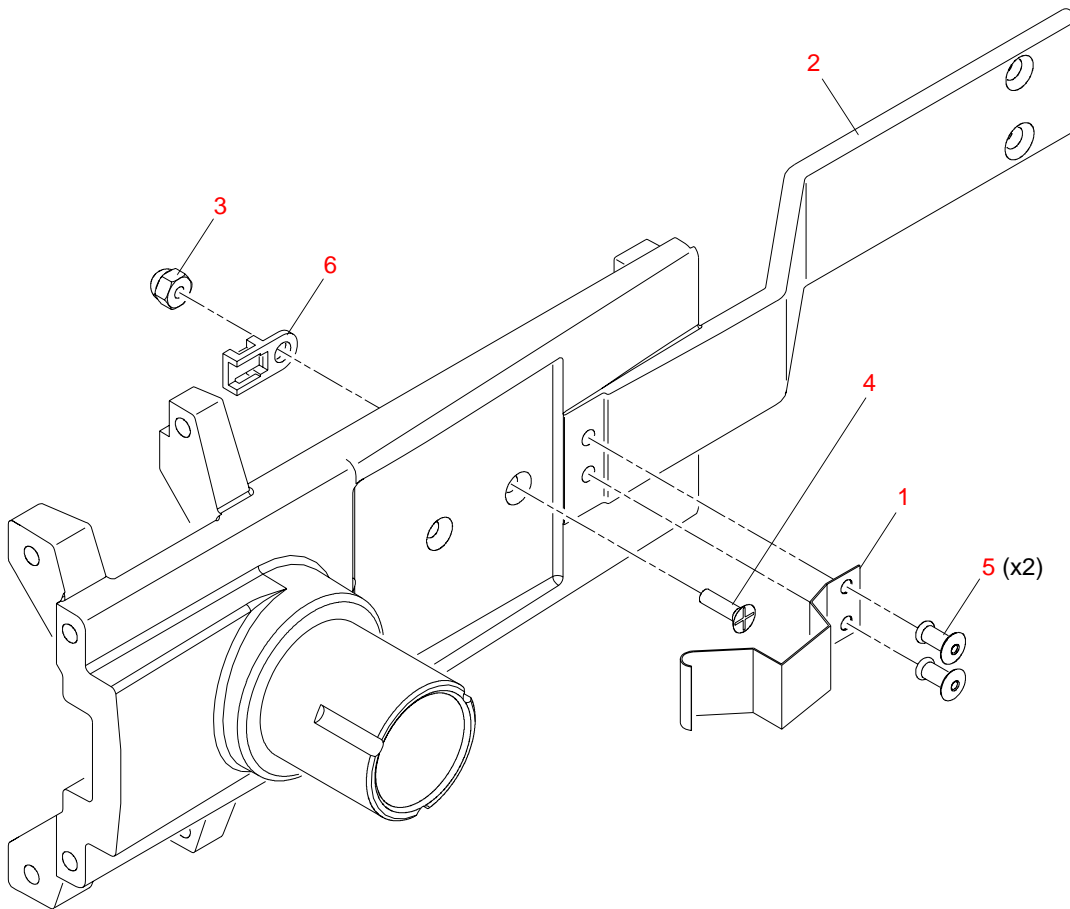

Figure 3-21: Pulley Side Rail Assembly

Sensor Side Rail Assembly

21.9663.1034 Rev B

Refer to [Figure 3-22](#).

No.	Item	Qty.	UM.	Description
1	10.9663.1026	1	EA	LATCH, SPRING
2	12.9663.1029	1	EA	RAIL, SIDE MACHINED SHORT TILT TUBE
3	53.2002.0004	1	EA	NUT, 6-32 ACORN THREAD LOCKING SS
4	53.5636.0625	1	EA	SCREW, 6-32 X 5/8" PFSS BLACK
5	53.6530.0009	2	EA	RIVET, 1/8"OD POP .126-.187GL STL BODY STL MNDRL DOME

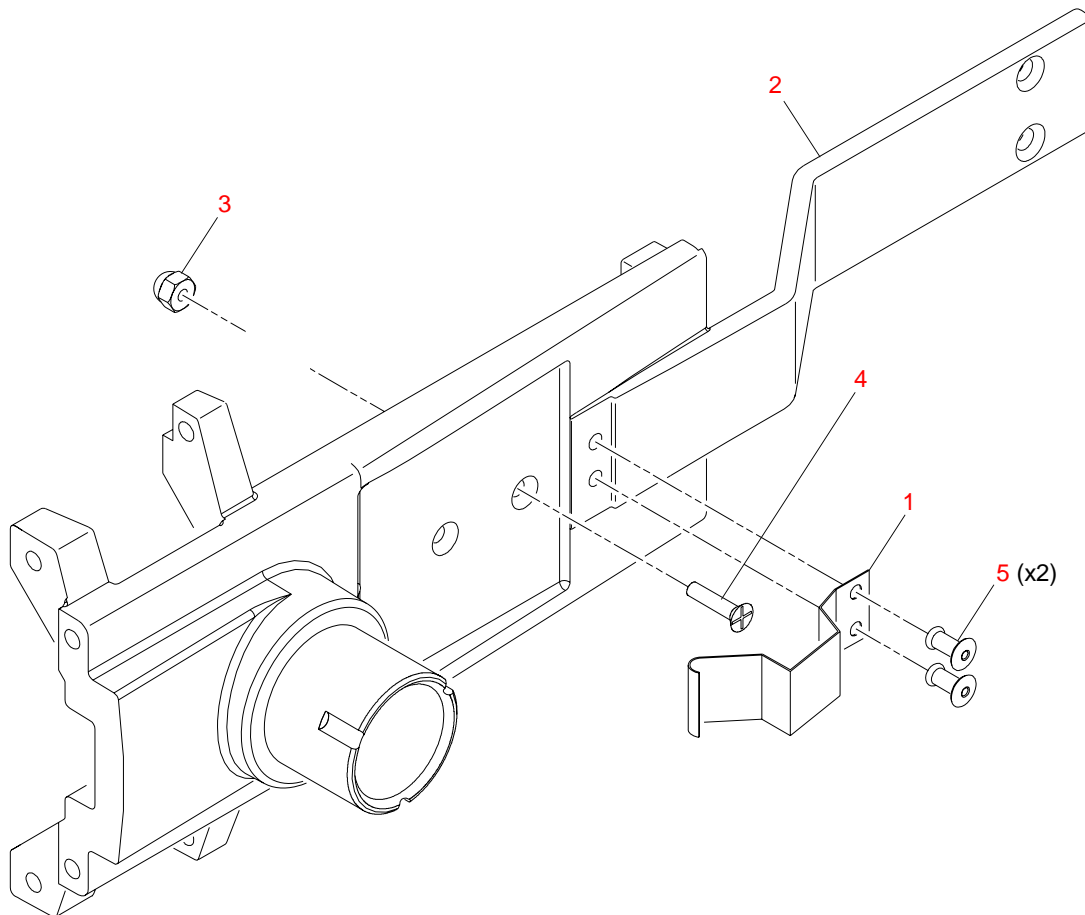

Figure 3-22: Sensor Side Rail Assembly

Incandescent Gobo Wheel Assembly

21.9663.1200 (TS/TI/TSD/TID) Rev V

Refer to [Figure 3-23](#).

No.	Item	Qty.	UM.	Description
1	10.9663.1212	1	EA	PULLEY, MOTOR -GOBO
2	10.9663.1214	1	EA	SHAFT, ROTATING GOBO
3	10.9663.1217	1	EA	PULLEY, GOBO DRIVE MOTOR MOUNTED
4	10.9663.1241	2	EA	PULLEY, IDLER TEFLON
5	10.9663.1242	2	EA	SPACER, PIVOT BELT ADJUST
6	10.9663.1228	1	EA	PLATE, GOBO IDLER MOUNT PLATE
7	10.9663.1229	1	EA	PLATE, WHEEL IDLER MOUNT
8	10.9663.1239	2	EA	MOUNT, SENSOR BOARD
9	21.9663.1201	1	EA	ASSY, GOBO WHEEL
10	22.9663.1226	1	EA	ASSY, GOBO BULKHEAD
11	23.9663.1248.01	1	EA	ELEC ASSY, TEMPERATURE SENSOR
12	24.9663.3230	1	EA	PCB ASSY, WHEEL SENSOR
13	24.9663.3231	1	EA	PCB ASSY, INDEX SENSOR
14	44.9663.1202	2	EA	MOTOR, 17 2.42" SHAFT 11.8MH 5.5 OHM
15	53.2003.0001	3	EA	NUT, 4-40 KEPS ZINC PLATED
16	53.5560.0187	4	EA	SCREW, 8-32 X .187" SET CONE POINT
17	53.6520.0001	1	EA	SCREW, 4-40 X 3/8" PPZ
18	53.6524.0002	4	EA	SCREW, 6-32 X 5/16" PPB
19	53.6530.0022	2	EA	RIVET, 1/8"OD POP .188-250GRP CSK HD AL W/STL MNDRL
20	53.6530.0023	1	EA	RIVET, 1/8"OD POP .376-.500GRP DOME HD W/STL MNDRL
21	53.6537.0001	1	EA	SCREW, 4-40 X 5/8" PPB (VL 1)
22	53.6543.0001	1	EA	SCREW, 6-32 X 3/8" PPB
23	53.6581.0001	2	EA	SCREW, 4-40 X 1 3/8" PFZ
24	53.6598.0312	4	EA	SCREW, 4-40 X 5/16" PFB
25	53.6600.0001	3	EA	SCREW, 4-40 X 5/16" PPB
26	53.6614.0001	2	EA	SCREW, 6-32 X 5/8" PPB
27	54.2045.0002	1	EA	BELT, TIMING MXL .080" PITCH .187W 250 TEETH SILICONE
28	54.9663.1220	1	EA	BELT, TIMING INDEX
29	55.6520.0001	2	EA	WASHER, WAVE SPRING, .265 ID X .367 OD
30	55.6506.0010	1	EA	SPACER, 1/4" RND .375" LG .140" ID THRU AL NO FNISH

No.	Item	Qty.	UM.	Description
31	55.6512.0001	1	EA	WASHER, #4 SPLIT LOCK
32	55.6538.0001	1	EA	SCREW, #6 LOCK INTERNAL TOOTH
33	55.6568.0061	2	EA	SPRING, EXTSN .250"OD 2.00"LG .022" WIRE DIA MUSIC WIRE
34	55.6609.0005	2	EA	WASHER, .625"OD .376"ID .020"THK FLAT TEFLON
35	55.6621.0003	1	EA	WASHER, #4 3/8" OD FLAT ZINC (changed 07-18-03)
36	55.6677.0035	1	EA	WASHER, .750"OD .187"ID .030"THK FLAT SS
37	55.6677.0036	1	EA	WASHER, .875"OD .406"ID .030"THK FLAT SS
38	55.6677.0039	2	EA	WASHER, .438"OD .219"ID .042"THK #12 FLAT CSTL
39	55.6677.0040	5	EA	WASHER, .624"OD .145"ID .030"THK FLAT BLACK OXIDE
40	55.6677.0042	1	EA	WASHER, .500"OD .145"ID .031"THK FLAT TEFLON
41	55.6706.0001	1	EA	GROMMET, 9/32"ID 9/16"OD 1/4T SILICONE RED
42	55.6818.0002	1	EA	STANDOFF, 45 DEG NYLON 6/6 KURLY-LOK

Incandescent Gobo Wheel Assy (continued)

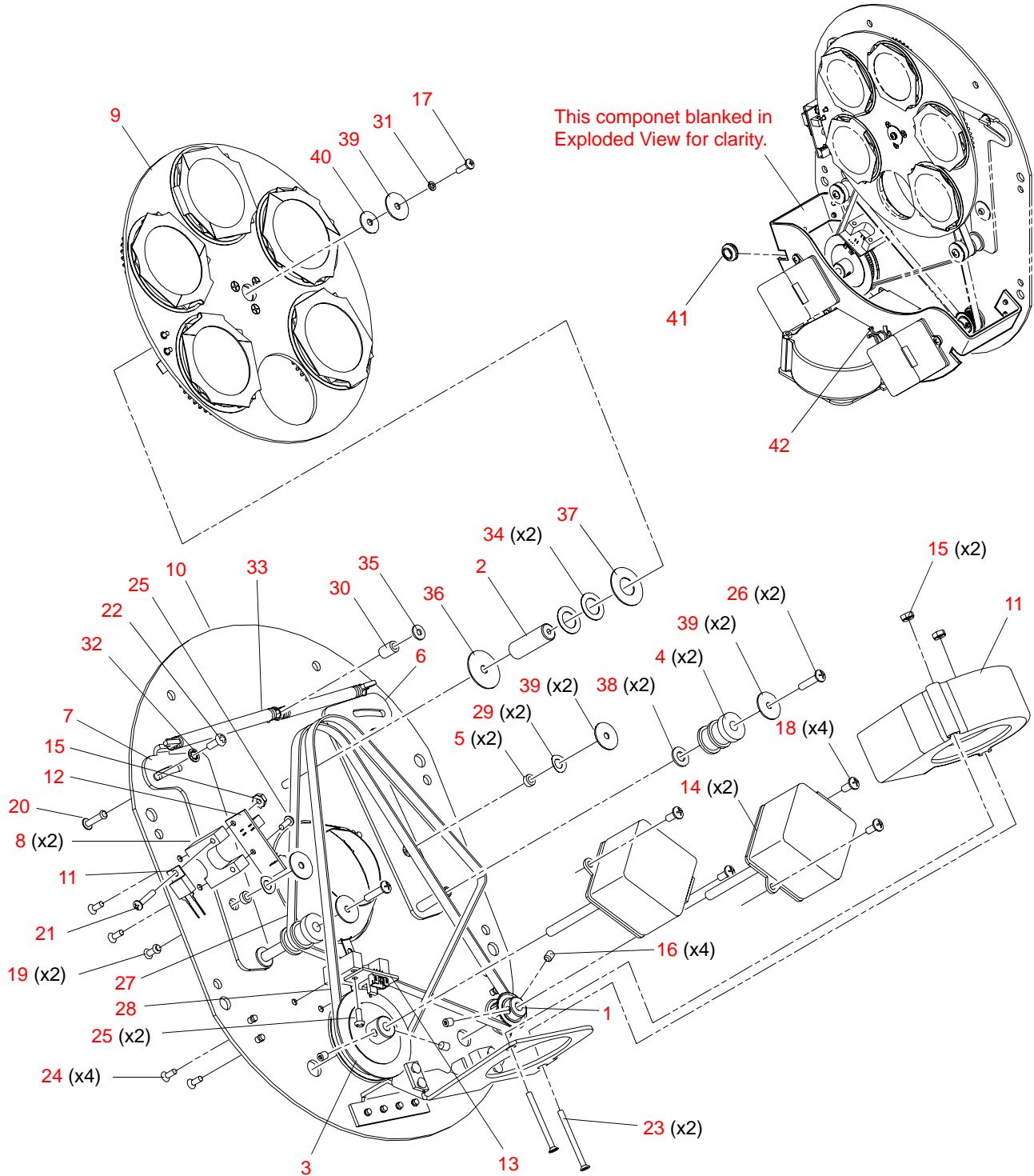

Figure 3-23: Incandescent Gobo Wheel Assembly

Temperature Sensor Electrical Assembly

23.9663.1248.01 (TS) Rev A

23.9663.1248.11 (AS) Rev A

Refer to [Figure 3-24](#).

No.	Item	Qty.	UM.	Description
1	23.9663.2008	1	EA	ASSY, FAN (TS ONLY)
	- 40.7140.0001	1	EA	BLOWER, CENTRIFUGAL 24VDC 9CFM 3" X 3"
	- 52.8347.0001	2	EA	CONTACT, 24-30AWG MALE CRIMP
2	52.6523.0004	1	EA	CONN, HOUSING 4POS PLUG SHROUDED WIRE TO WIRE
3	52.8347.0001	2	EA	CONTACT, 24-30AWG MALE CRIMP
4	55.2198.0001	.17	FT	HEATSHRINK 1/8" BLACK
5	63.2047.0001	1	EA	THERMOSTANT, 100 DEG C PCB MOUNT CLOSE ON RISE
6	73.3524.0002	2.5	FT	WIRE 24AWG 300V 105C PVC RED UL1007
-	25.9663.0390	1	EA	WIRE ASSEMBLY, JUMPER, THERMOSTAT (NOT SHOWN*)

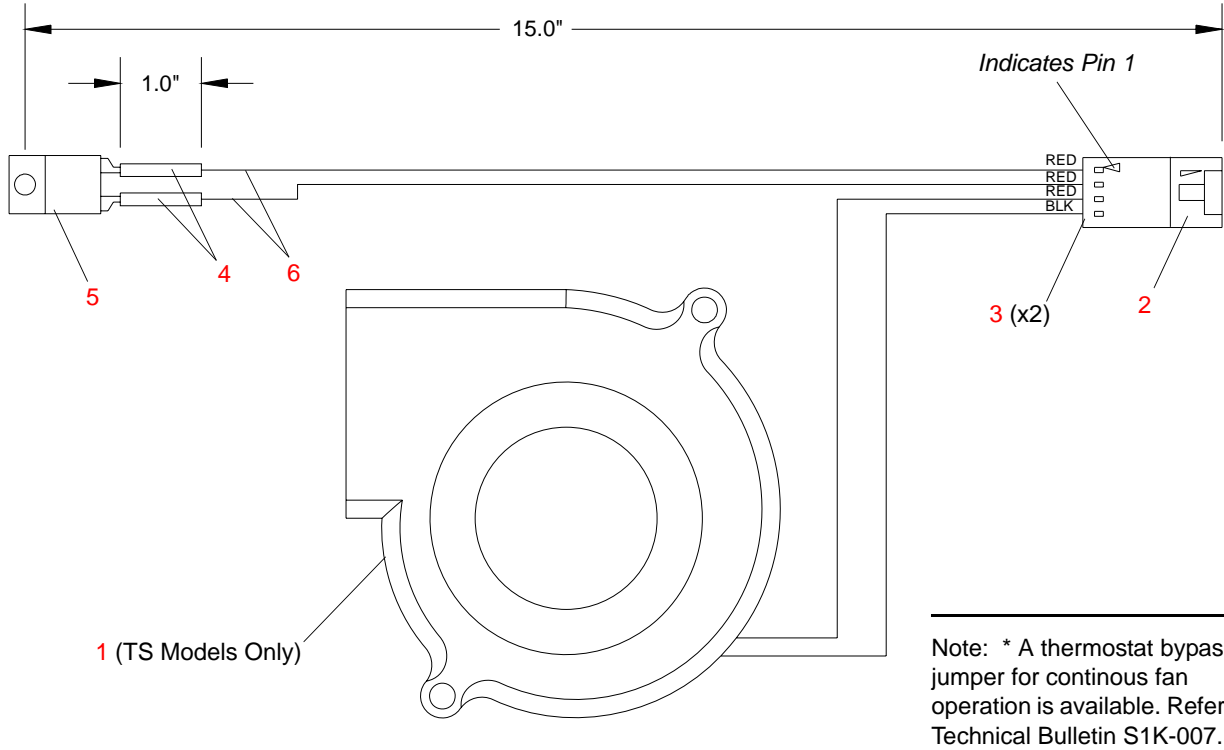

Figure 3-24: Temperature Sensor Electrical Assembly

Arc Gobo/Dimmer Bulkhead Assembly

21.9663.1600 (AS) Rev T

Refer to [Figure 3-25](#).

No.	Item	Qty.	UM.	Description
1	10.9663.1212	2	EA	PULLEY, MOTOR -GOBO
2	10.9663.1214	1	EA	SHAFT, ROTATING GOBO
3	10.9663.1217	1	EA	PULLEY, GOBO DRIVE MOTOR MOUNTED
4	10.9663.1228	1	EA	PLATE, GOBO IDLER MOUNT PLATE
5	10.9663.1229	1	EA	PLATE, WHEEL IDLER MOUNT
6	10.9663.1239	2	EA	MOUNT, SENSOR BOARD
7	10.9663.1241	2	EA	PULLEY, IDLER TEFLON
8	10.9663.1242	2	EA	SPACER, PIVOT BELT ADJUST
9	10.9663.1621	1	EA	PULLEY, W/FLANGES 26GROOVE .25 WIDE MXL-DIMMER/GOBO ASSY
10	10.9663.1625	1	EA	SHAFT, DIMMER .250 OD
11	10.9663.1635	1	EA	SHAFT SUPPORT, DIMMER
	54.1259.0002	2	EA	BEARING, RADIAL, .251 ID X .625 OD (NOT SHOWN)
	55.6506.0029	1	EA	SPACER, 9/32" RND X .250" LG X .253" ID THRU AL (NOT SHOWN)
12	10.9663.1630	2	EA	SEAL, COVER LONG
13	10.9663.1631	2	EA	SEAL, COVER SHORT
14	10.9663.1632	2	EA	PLATE, COVER SEAL LONG
15	10.9663.1633	2	EA	PLATE, COVER SEAL SHORT
16	21.9663.1201	1	EA	ASSY, GOBO WHEEL
17	22.9663.1232	1	EA	FAB ASSY, DIMMER/GOBO BULKHEAD
18	22.9663.1629	1	EA	GLASS, DIMMER WHEEL
19	23.9663.1248.11	1	EA	ELEC ASSY, TEMPERATURE SENSOR
20	24.9663.3230	1	EA	PCB ASSY, WHEEL SENSOR
21	24.9663.3231	1	EA	PCB ASSY, INDEX SENSOR
22	44.9663.1202	3	EA	MOTOR, 17 2.42" SHAFT 11.8MH 5.5 OHM
23	53.2002.0001	1	EA	NUT, 6-32 KEP ZINC PLATED
24	53.2003.0001	1	EA	NUT, 4-40 KEP ZINC PLATED
25	53.6520.0001	1	EA	SCREW, 4-40 X 3/8" PPZ
26	53.5560.0187	10	EA	SCREW, 8-32 X .187" SET CONE POINT
27	53.6524.0002	6	EA	SCREW, 6-32 X 5/16" PPB
28	53.6530.0022	2	EA	RIVET, 1/8"OD POP .188-250GRP CSK HD AL W/STL MNDRL

No.	Item	Qty.	UM.	Description
29	53.6530.0023	1	EA	RIVET, 1/8"OD POP .376-500GRP DOME HD W/STL MNDRL
30	53.6534.0001	18	EA	RIVET, 3/32"OD POP 3/32GRIP RANGE ALUM
31	53.6537.0001	1	EA	SCREW, 4-40 X 5/8" PPB (VL 1)
32	53.6543.0001	1	EA	SCREW, 6-32 X 3/8" PPB
33	53.6598.0312	7	EA	SCREW, 4-40 X 5/16" PFB
34	53.6600.0001	3	EA	SCREW, 4-40 X 5/16" PPB
35	53.6614.0001	2	EA	SCREW, 6-32 X 5/8" PPB
36	53.6682.0002	2	EA	SCREW, 4-40 X 1/4"LG PPZ SEMS-EXT
37	54.2045.0002	1	EA	BELT, TIMING MXL .080" PITCH .187W 250 TEETH SILICONE
38	54.2050.0001	1	EA	BELT, TIMING MXL .080" PITCH 93 TEETH 1/4" WD SILICONE
39	54.9663.1220	1	EA	BELT, TIMING INDEX
40	55.6520.0001	2	EA	WASHER, WAVE SPRING, .265 ID X .367 OD
41	55.6506.0010	1	EA	SPACER, 1/4" RND .375"LG .140"ID THRU AL NO FNSH
42	55.6512.0001	3	EA	WASHER, #4 SPLIT LOCK
43	55.6538.0001	1	EA	WASHER, #6 LOCK INTERNAL TOOTH
44	55.6568.0061	2	EA	SPRING, EXTSN .250"OD 2.00"LG .022" WIRE DIA MUSIC WIRE
45	55.6609.0005	2	EA	WASHER, .625"OD .376"ID .020"THK FLAT TEFLON
46	55.6621.0003	1	EA	WASHER, #4 3/8" OD FLAT ZINC (changed 07-18-03)
47	55.6659.0007	2	EA	STANDOFF, 3/16" HEX 4-40 .250"LG ALUM
48	55.6677.0035	1	EA	WASHER, .750"OD .187"ID .030"THK FLAT SS
49	55.6677.0036	1	EA	WASHER, .875"OD .406"ID .030"THK FLAT SS
50	55.6677.0039	2	EA	WASHER, .438"OD .219"ID .042"THK #12 FLAT CSTL
51	55.6677.0040	5	EA	WASHER, .624"OD .145"ID .030"THK FLAT BLACK OXIDE
52	55.6677.0042	1	EA	WASHER, .500"OD .145"ID .031"THK FLAT TEFLON
53	55.6706.0001	1	EA	GROMMET, 9/32" ID 9/16" OD 1/4T SILICONE RED
54	55.6818.0002	1	EA	STANDOFF, 45 DEG NYLON 6/6 KURLY-LOK

Arc Gobo/Dimmer Bulkhead (continued)

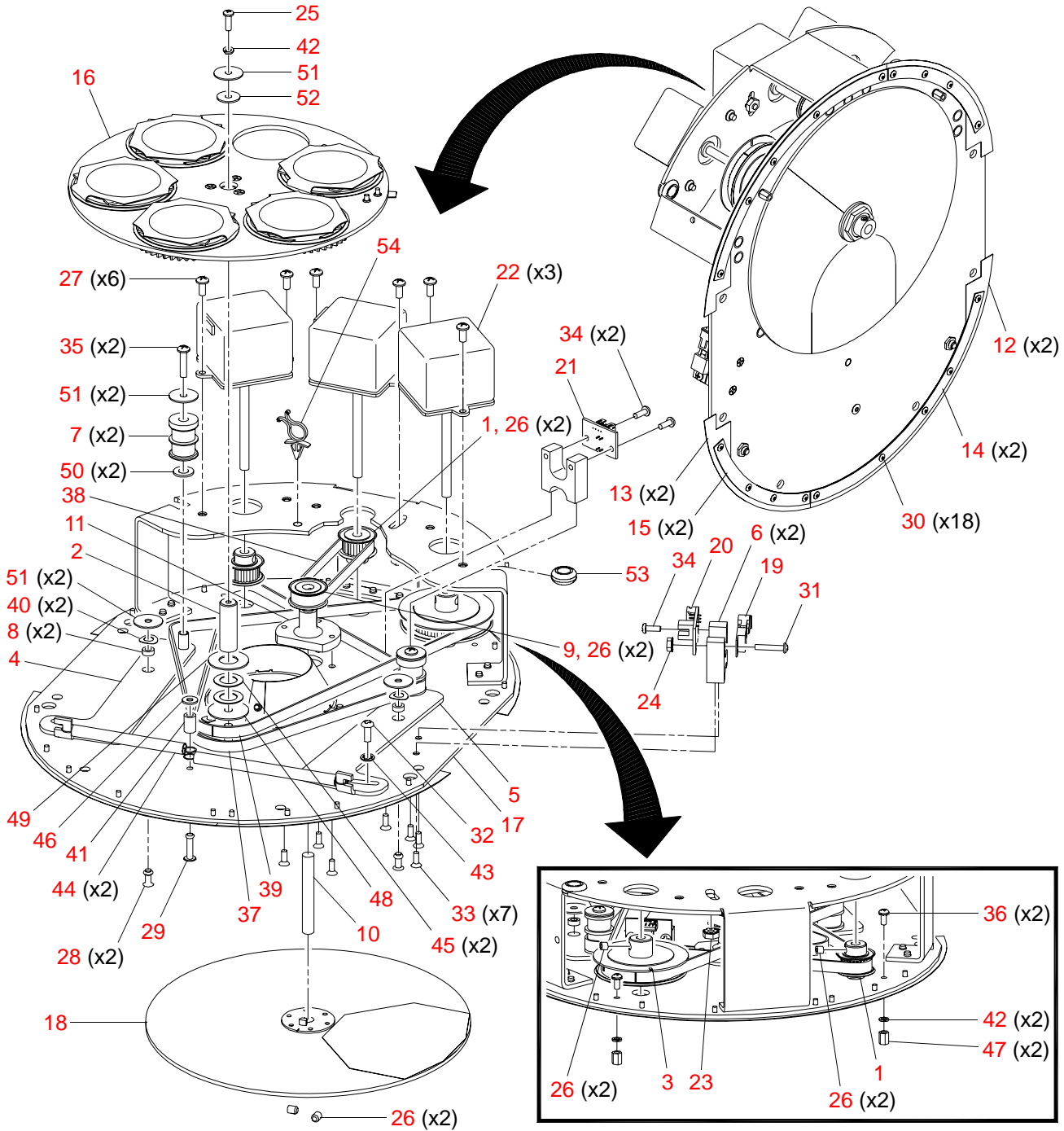

Figure 3-25: Arc Gobo/Dimmer Bulkhead Assembly

Gobo Wheel Assembly

21.9663.1201 Rev E

Refer to [Figure 3-26](#).

No.	Item	Qty.	UM.	Description
1	10.9663.2203	5	EA	GEAR, PLANET, MACHINED ALUMINUM
2	10.9663.1204	1	EA	WHEEL, ROTATING GOBO
3	10.9663.1206	1	EA	FLANGE, MIDDLE
4	10.9663.1210	5	EA	CLIP, RETAINING
5	10.9663.1211	10	EA	SPACER, TEFLON GOBO GEAR
6	10.9663.1219	1	EA	SUN GEAR, MOLDED
7	10.9663.1247	1	EA	TAB, GOBO WHEEL SENSOR
8	10.9663.1240	5	EA	BEARING, GOBO WHEEL BORE
9	22.9663.1222	1	EA	PULLEY ASSY, GOBO WHEEL
10	53.6534.0001	2	EA	RIVET, 3/32" OD, 3/32 GRIP RANGE, ALUM
11	53.6598.0312	3	EA	SCREW, 4-40 X 5/16" PFB
12	55.6504.0004	3	EA	WASHER, #4 LOCK CSK EXT TOOTH (added 02-13-03)

Gobo Wheel Assembly (continued)

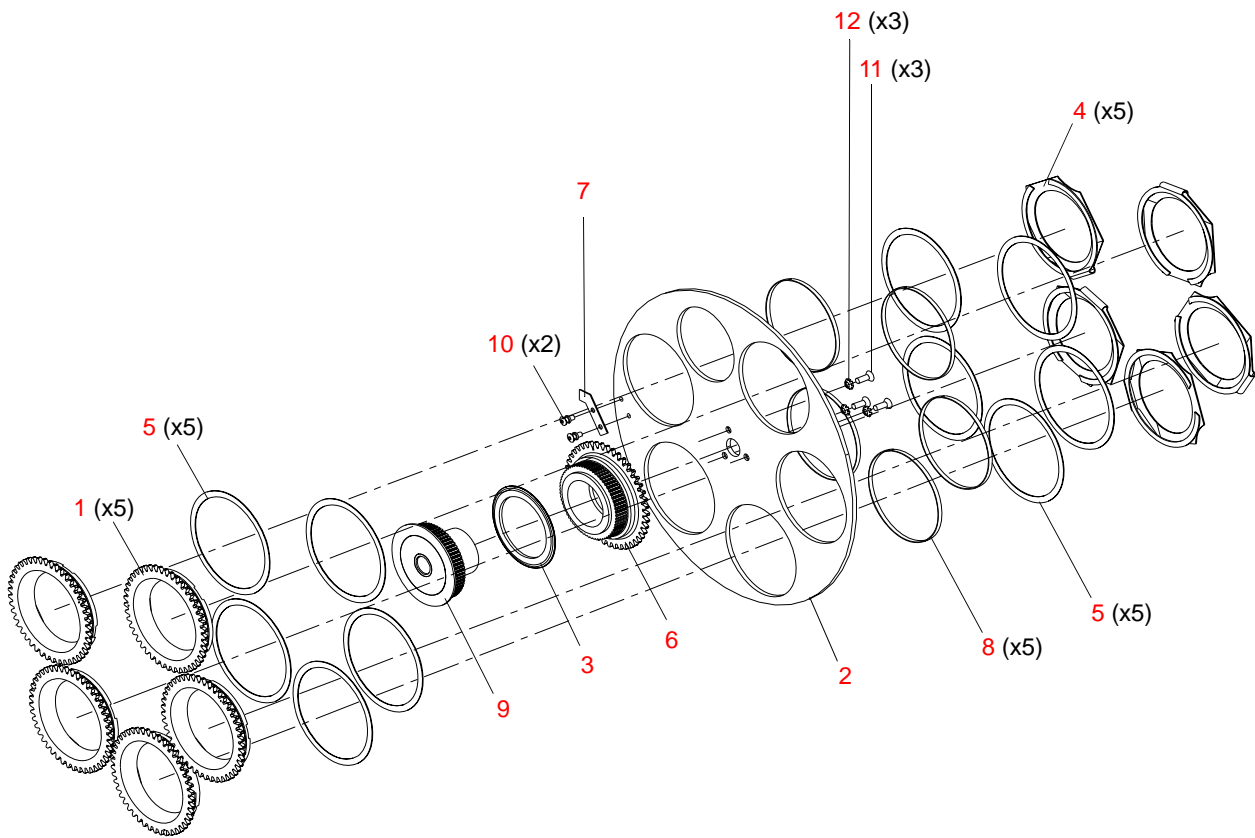

Figure 3-26: Gobo Wheel Assembly

Shutter 6 Rollers Assembly

21.9663.1350 Rev B

Refer to [Figure 3-27](#).

No.	Item	Qty.	UM.	Description
1	10.9663.1311	2	EA	SEPARATOR, SHUTTER
2	10.9663.1313	1	EA	COVER, SHUTTER
3	10.9663.1314	8	EA	RACK, SHUTTER
4	10.9663.1320	8	EA	PAD, MOTOR
5	10.9663.1321	1	EA	CLAMP RING, MOTOR
6	10.9663.1325	6	EA	ROLLER, NYLON
7	10.9663.1327	1	EA	GEAR, SHUTTER ROTATE SECTOR
8	10.9663.1328	1	EA	BULKHEAD, SHUTTER MACHINED
9	10.9663.1330	1	EA	PINON, SHUTTER
10	10.9663.1380	4	EA	SPACER, SHUTTER (changed 01-13-03)
11	10.9663.1381	3	EA	STIFF SEPARATOR, SHUTTER (changed 01-13-03)
12	10.9663.1339.02	1	EA	DONUT, ANTI-REFLECTION, SHUTTER
13	10.9663.1351	1	EA	BASE PLATE, SHUTTER 6 ROLLERS
14	12.9663.1323	2	EA	BLADE, SHUTTER COATED SIDE A
15	12.9663.1324	2	EA	BLADE, SHUTTER COATED SIDE B
-	25.9663.2040	1	EA	CABLE ASSY, BEAM SHAPER HARNESS - (NOT SHOWN)
16	44.9663.1326	1	EA	MOTOR, 17 .53" SHAFT 11.8MH 5.5 OHM
17	44.9663.1351	8	EA	ASSY, SHUTTER MOTOR (changed 05-22-03)
18	53.2200.0006	1	EA	NUT, 6-32 KEPS SS
19	53.2202.0004	4	EA	NUT, 4-40 HEX SS NYLON INSERT
20	53.2202.0006	2	EA	NUT, 6-32 HEX SS NYLON INSERT
21	53.5638.0252	4	EA	SCREW, 6-32 X 1/4" LG PFS UNDERCUT HEAD
22	53.6523.0013	6	EA	SCREW, 6X32 3/8 LG PTB TRUSS HD BLK ZINC (added 07-24-02)
23	53.6525.0001	4	EA	SCREW, 6-32 X 5/16" PPZ
24	53.6526.0001	2	EA	SCREW, 6-32 X 5/8" PPZ
25	53.6536.0001	2	EA	SCREW, 4-40 X 1/2" PFZ
26	53.6613.0001	1	EA	SCREW, 6-32 X 1/2" PPZ
27	55.2178.0002	1	EA	CABLE ANCHOR MOUNT, #10 SCREW MOUNTING
-	55.2180.0002	.25	FT	SPIRAL WRAP, 3/8" OD TEFLON (NOT SHOWN)
28	55.3303.0006	4	EA	WASHER, #6 LOCK INT. TOOTH SS

VARI*LITE® - VL1000™ ERS LUMINAIRE SERVICE MANUAL

No.	Item	Qty.	UM.	Description
29	55.6621.0001	4	EA	WASHER, #4 FLAT ZINC
30	55.6697.0020	2	EA	STANDOFF, 3/16" RND, 4-40, .375"LG, ZINC PLATED STEEL

Shutter Assembly (continued)

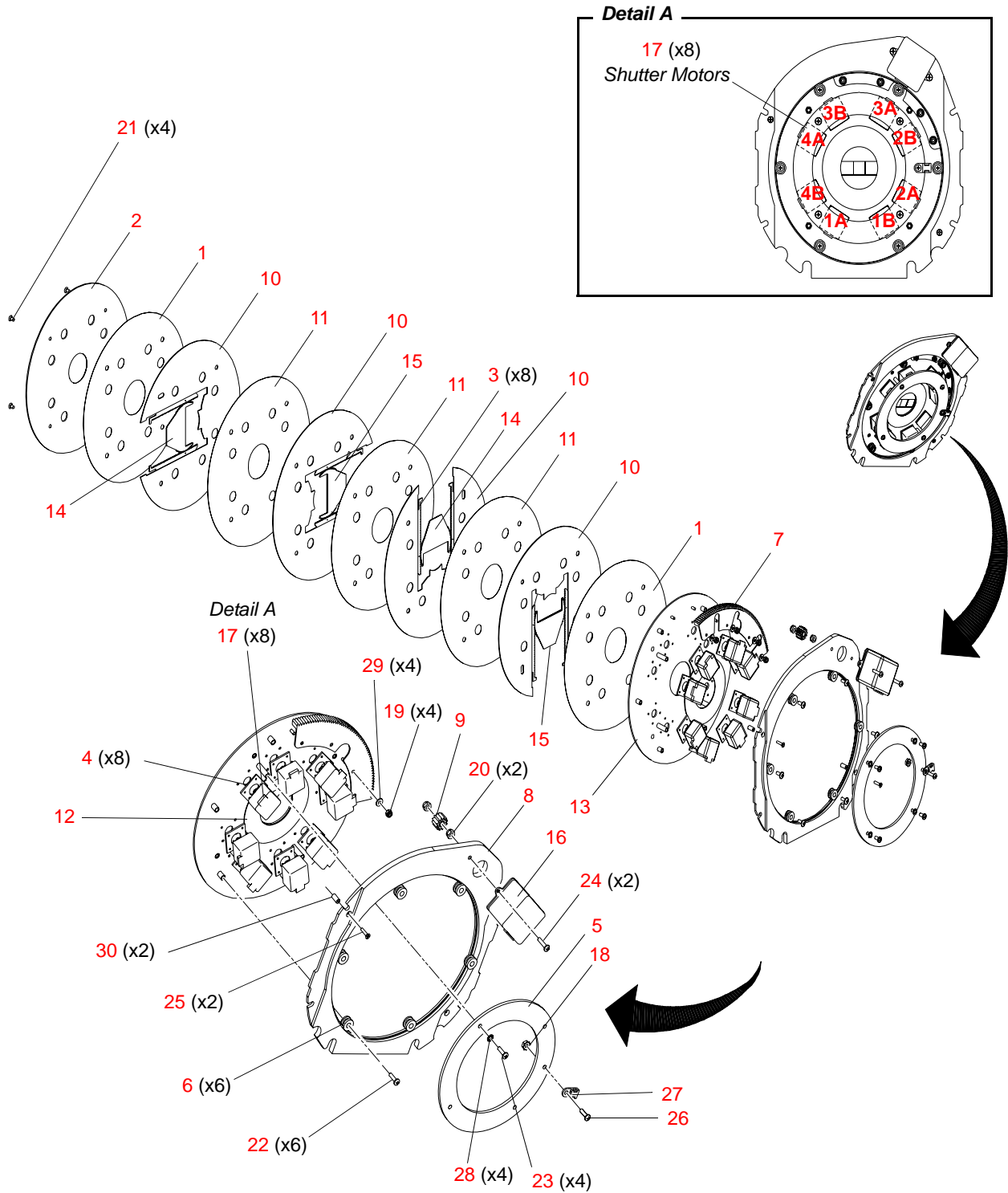

Figure 3-27: Shutter 6 Rollers Assembly

Beam-Size Iris Assembly

21.9663.1400 Rev E

Refer to [Figure 3-28](#).

No.	Item	Qty.	UM.	Description
1	10.9663.1339.03	1	EA	DONUT, ANTI-REFLECTION IRIS
2	10.9663.1411	1	EA	BULKHEAD, IRIS
3	21.9663.1409	1	EA	ASSY, MOTOR ARM
	- 10.9663.1402	1	EA	ARM, MOTOR
	- 10.9663.1406	1	EA	BOSS, MOTOR ARM
	- 53.6659.0008	3	EA	SCREW, 2-56 X 3/16" PFZ
4	22.9663.1410	1	EA	IRIS, 67MM OD
5	44.9663.1326	1	EA	MOTOR, 17 .53" SHAFT 11.8MH 5.5 OHM
6	53.5560.0250	1	EA	SCREW, 8-32 X 1/4" SET CONE POINT
7	53.6513.0042	3	EA	SCREW, M2 X .4 X 4MM LG PFB METRIC
8	53.6543.0003	2	EA	SCREW, 6-32 X 3/16" PPB
9	53.6605.0200	1	EA	STUD, 2-56 X 2.0"LG FULL THREAD STAINLESS STEEL
10	54.1217.0005	2	EA	KWIK LINK, 2-56 SPRING STEEL
	55.6538.0005	4	EA	WASHER, TEFLON, .25" OD, .065" ID, .015" THK (NOT SHOWN)
11	55.6546.0004	1	EA	WASHER, TEFLON, .201 ID X .438 OD X .040 THK

Beam-Size Iris Assembly (continued)

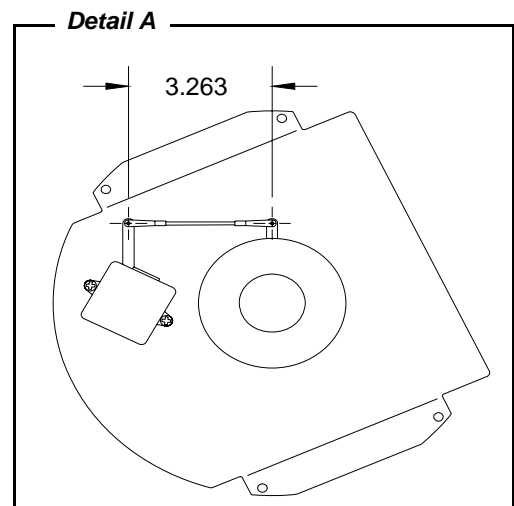
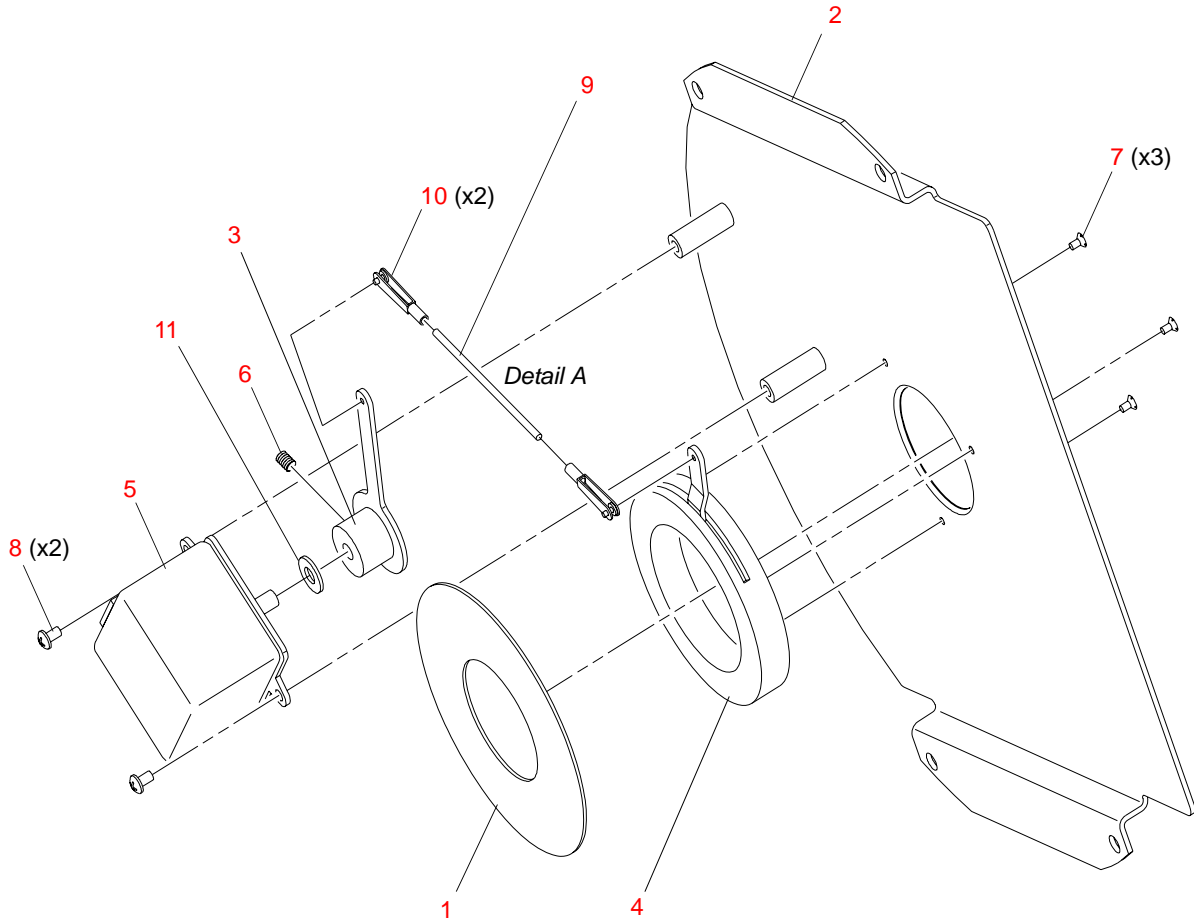

Figure 3-28: Beam-Size Iris Assembly

Rear Head Assembly

21.9663.1002.01 Rev P (TS/TI)

21.9663.1002.11 Rev P (AS/AI)

Refer to [Figure 3-29](#).

No.	Item	Qty.	UM.	Description
1	10.9634.0100	3	EA	CLIP,MOUNTING,REFLECTOR
2	10.9663.1104	1	EA	REFLECTOR MOUNT
3	10.9663.1109	2	EA	COUNTERWEIGHT
4	12.9663.1023	1	EA	CASTING, REAR MACHINED
5	21.9663.1101.01	1	EA	ASSY, INC BULKHEAD (TS/TI ONLY)
	21.9663.1101.11	1	EA	ASSY, ARC BULKHEAD (AS/AI ONLY)
6	21.9663.1127.01	1	EA	ASSY, BACK CAP (TS/TI ONLY)
	21.9663.1127.11	1	EA	ASSY, BACK CAP (AS/AI ONLY)
-	25.9663.2033	REF	EA	CABLE ASSY, LAMP POWER INCANDESCENT (TS/TI ONLY) NOT SHOWN
-	25.9663.2036	REF	EA	CABLE ASSY, IGNITOR TO LAMP SOCKET (AS/AI ONLY) NOT SHOWN
7	42.9663.7237	1	EA	REFLECTOR, 48 LUNE (TS/TI ONLY)
	42.9663.7118	1	EA	REFLECTOR, 8, 10, 14 DEGREE LUNES FACETED (AS/AI ONLY)
8	53.2002.0001	3	EA	NUT, 6-32 KEP ZINC PLATED
9	53.6522.0005	4	EA	SCREW, 6-32 X 3/8" LG PFZ TYPE F
10	53.6553.0004	8	EA	SCREW, 10-32 X 3/8"LG PPB TYPE F
11	53.6607.0001	3	EA	SCREW, 6-32 X 1/4" PPB
12	53.6682.0037	1	EA	SCREW, 10-32 X 1/2" LG PPZ SEMS-EXT
13	55.3301.0010	1	EA	WASHER, #10 FLAT
14	55.6636.0004	1	EA	WASHER, #10 FENDER ZINC PLT SS 1.250"OD .219"ID .047"THK

Rear Head Assembly (continued)

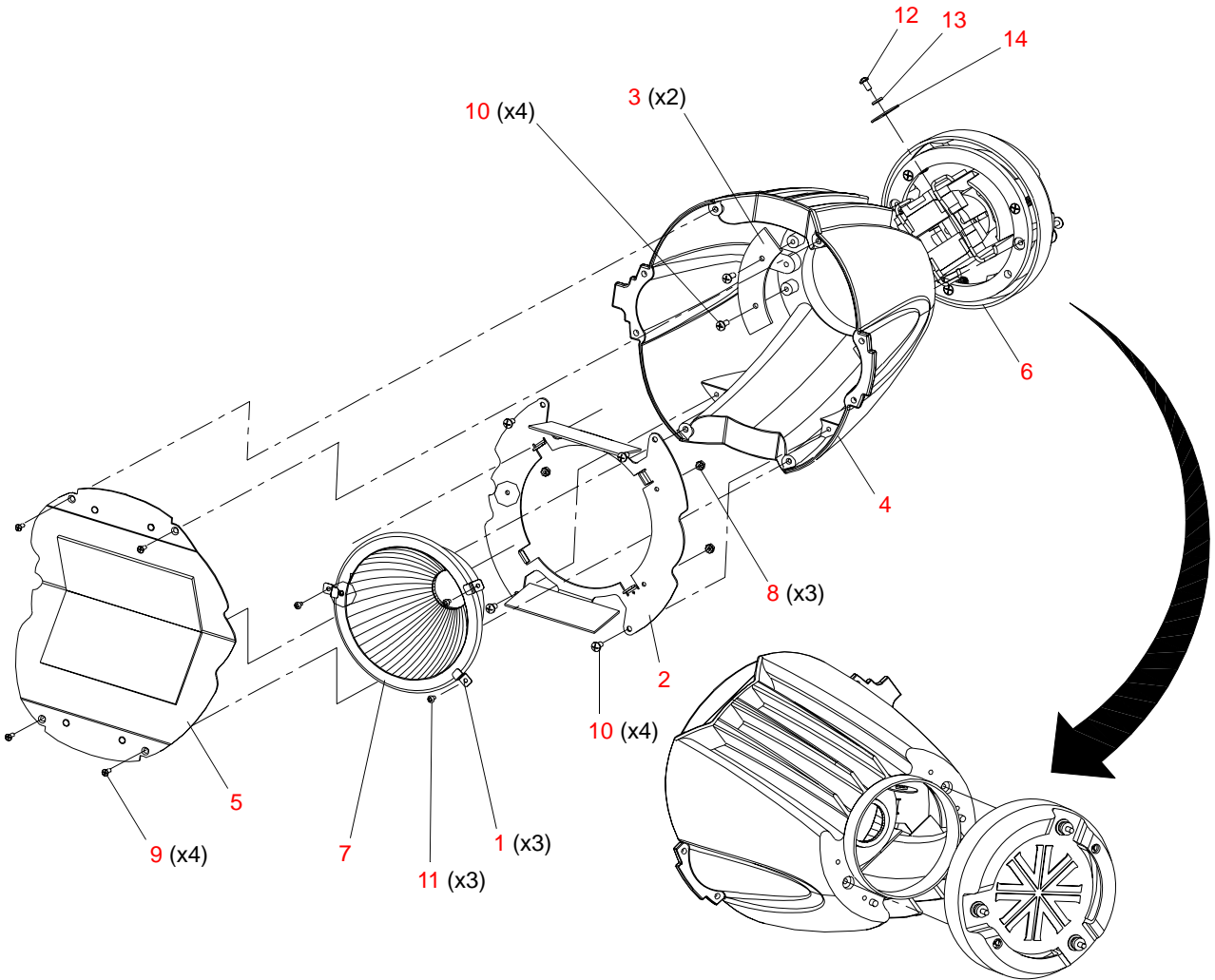

Reflector Orientation

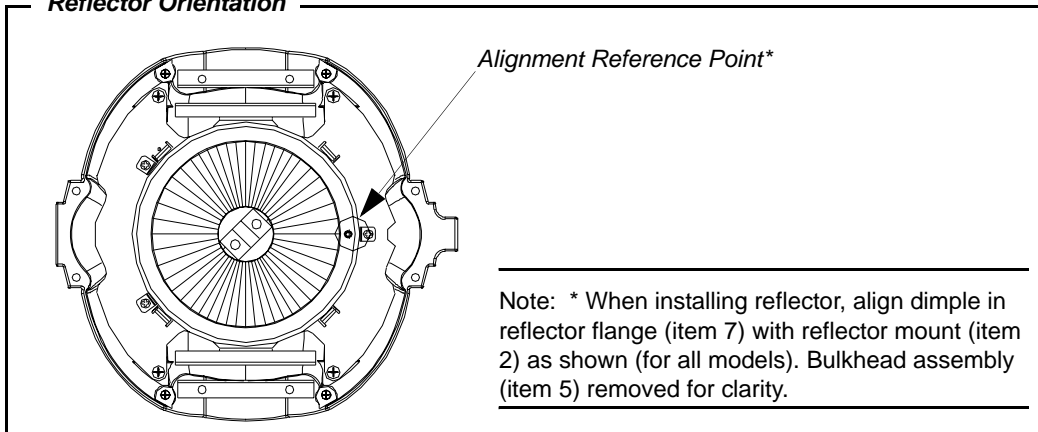

Figure 3-29: Rear Head Assembly

Back Cap Assembly

21.9663.1127.01 (TS/TI) Rev J

21.9663.1127.11 (AS/AI) Rev J

Refer to [Figure 3-30](#).

No.	Item	Qty.	UM.	Description
1	10.9663.1116	2	EA	CLAMP, LAMP BASE BAIL (TS/TI ONLY)
2	10.9663.1136	1	EA	PLATE, BACKCAP ADJUST
3	10.9663.1119	2	EA	LAMP BASE CLAMP (TS/TI ONLY)
4	12.9663.1126	1	EA	BACKCAP, MACHINED
5	10.9678.0645	3	EA	KNOB, LAMP ADJUST, MODLED (added 11-19-03)
6	53.2030.0001	3	EA	NUT, ACORN 10-32 THD, 3/8 W BLK ZINC (added 11-19-03)
7	53.5711.2500	2	EA	SCREW, 10-32 X 2 1/2" Phillips Truss Head SS Black (changed 10-31-02)
8	53.6539.0011	3	EA	SCREW, 10-32 X 2 1/4" PFBSS UNF-2A
9	55.6546.0004	3	EA	WASHER, TEFLON .201 ID .438 OD X .04 THK (added 11-19-03)
10	53.6575.0001	2	EA	SCREW, 8-32 X 1.0" PPZ
11	53.6575.0005	2	EA	SCREW, 8-32 X 1 1/2" PPZ (TS/TI ONLY)
12	55.6568.0059	3	EA	SPRING, CPRSN, .360" OD 1.50" LG .045" DIA SS
13	55.6704.0013	1	EA	STANDOFF, 1/4" HEX 8-32 .500" LG (TS/TI ONLY)
14	71.2560.0001	1	EA	SOCKET, LAMP G22 SCREW TERMINALS

Back Cap Assembly (continued)

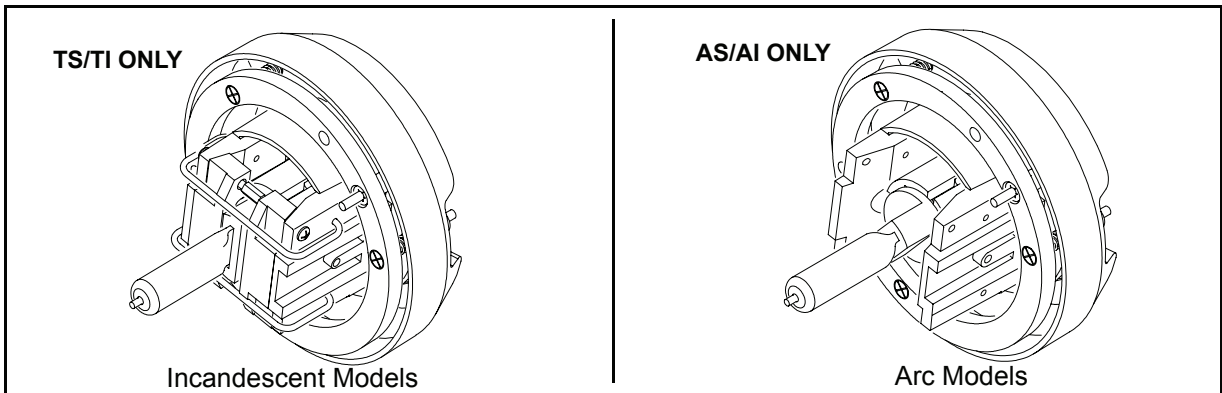
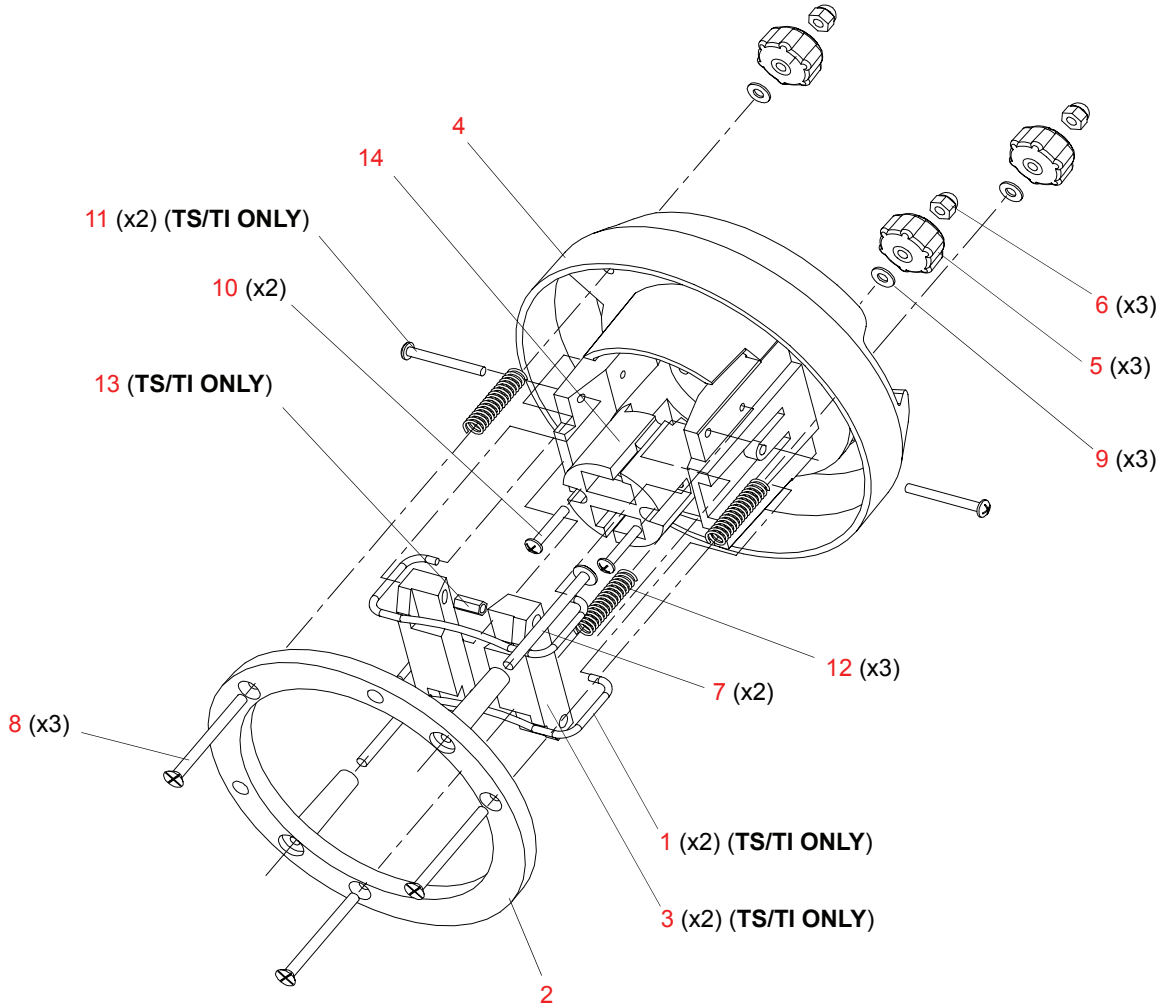

Figure 3-30: Back Cap Assembly

Notes

Yoke Assembly

Yoke Legs Assembly

21.9663.1850.01 (TS/TI) Rev J
 21.9663.1850.11 (AS/AI) Rev J
 21.9663.1850.21 (TSD/TID - 115V DIM) Rev J
 21.9663.1850.31 (TSE/TIE - 240V DIM) Rev J

Refer to [Figure 3-31](#).

No.	Item	Qty.	UM.	Description
1	10.9661.1364	1	EA	INSULATOR, ADHESIVE BACKED - TOP COVER (AS/AI ONLY)
2	10.9663.1827	2	EA	NUT PLATE, PAN/TILT MOTOR
3	10.9663.1842	2	EA	HEATSHIELD, YOKE LEG
4	10.9663.1852	1	EA	COUNTERWEIGHT, DIMMER (DIM ONLY)
5	21.9663.1816	1	EA	ASSY, TILT MOTOR
6	22.9663.1801	1	EA	ASSY, YOKE
7	24.9661.3126	1	EA	PCB ASSY, SOILD STATE IGNITOR (AS/AI ONLY)
8	24.9663.3230	1	EA	PCB ASSY, WHEEL SENSOR
-	25.9663.2002	1	EA	CABLE ASSY, TILT COT - NOT SHOWN
-	25.9663.2020	1	EA	CABLE ASSY, PAN/TILT CONTROL - NOT SHOWN
-	25.9663.2026	1	EA	CABLE ASSY, DIMMER TO CNTRLR - NOT SHOWN (DIM ONLY)
-	25.9663.2037	1	EA	CABLE ASSY, DIMMER TO LAMP SCKT - NOT SHOWN (DIM ONLY)
-	25.9663.2817	1	EA	CABLE ASSY, LVS CHASSIS GROUND - NOT SHOWN (TS/TI ONLY)
-	25.9663.2824	1	EA	CABLE ASSY, LVS DC OUTPUT - NOT SHOWN
-	25.9663.2826	1	EA	CABLE ASSY, DIMMER TO LVS - NOT SHOWN (DIM ONLY)
9	53.2019.0004	2	EA	NUT, 3/8-16 X 7/32"THK HEX JAM GRD5 ZINC PLT
10	53.6539.0001	2	EA	WASHER, 3/8" SPLIT LOCK
11	53.6543.0001	14	EA	SCREW, 6-32 X 3/8" PPB (AS/AI ONLY)
		10	EA	SCREW, 6-32 X 3/8" PPB (TS/TI ONLY)
12	53.6545.0007	4	EA	SCREW, 8-32 X 3/8" PFB (DIM ONLY)
13	53.6567.0001	3	EA	SCREW, 4-40 X 1/2" PPZ
14	53.6617.0001	4	EA	SCREW, 6-32 X 1" PPB
15	53.6634.0003	2	EA	SCREW, 3/8-16 X 1/2"LG SOC HD CAP ALLY STL
16	55.2140.0001	4	EA	STANDOFF, 1/4" HEX 6-32 .813"LG (AS/AI ONLY)
17	55.2143.0002	7	EA	STANDOFF, 1/4"HEX 6-32 1.375"LG FF ALUM

No.	Item	Qty.	UM.	Description
18	55.2203.0001	2	EA	SCREW, 4-40 X 1/4 " PPZ
19	55.2204.0001	3	EA	WASHER, #4 NYLON (AS/AI ONLY)
20	55.3301.0006	4	EA	WASHER, #6 FLAT SS
21	55.6525.0005	3	EA	WASHER, #4 SHOULDER NYLON .125 DP (AS/AI ONLY)
22	55.6568.0056	1	EA	SPRING, CPRSN .600"OD .625"LG .080"WIRE DIA MUSIC WIRE
23	55.6597.0003	4	EA	CLIP, CABLE SELF RETAINING 1/8" THK PANEL
24	67.4006.0006	1	EA	CLAMP, CABLE EMI SUP. FERRITE 0.52, 0.61 LG
25	69.3173.0115	1	EA	DIMMER, 1200W, 115V, REV PHASE CNTRL (TSD/TID ONLY)
	69.3173.0240	1	EA	DIMMER, 1200W, 240V, REV PHASE CNTRL (TSE/TIE ONLY)
26	69.3177.0151	1	EA	POWER SUPPLY, 150W +24V/6.3A (changed 08-28-03)

Yoke Mount Configurations -

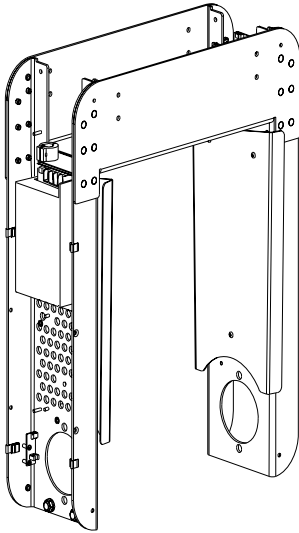

VL1000 TS, TI Units

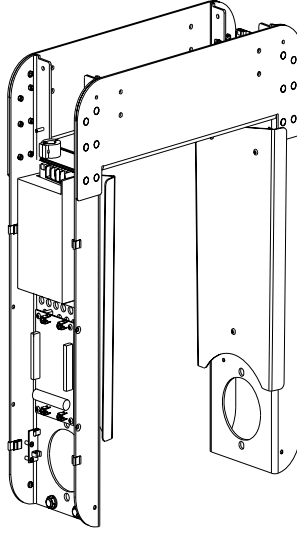

VL1000 AS, AI Units

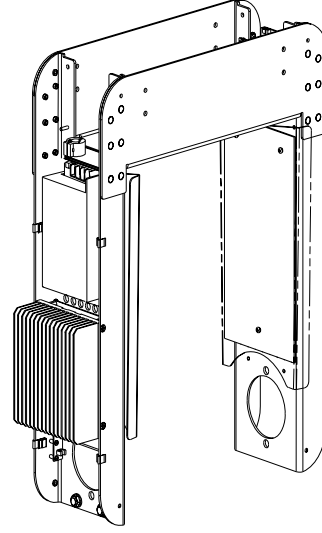

*VL1000 TSD, TID Units
(With Integral 115V Dimmer)
VL1000 TSE, TIE Units
(With Integral 230V Dimmer)*

Yoke Legs Assembly (continued)

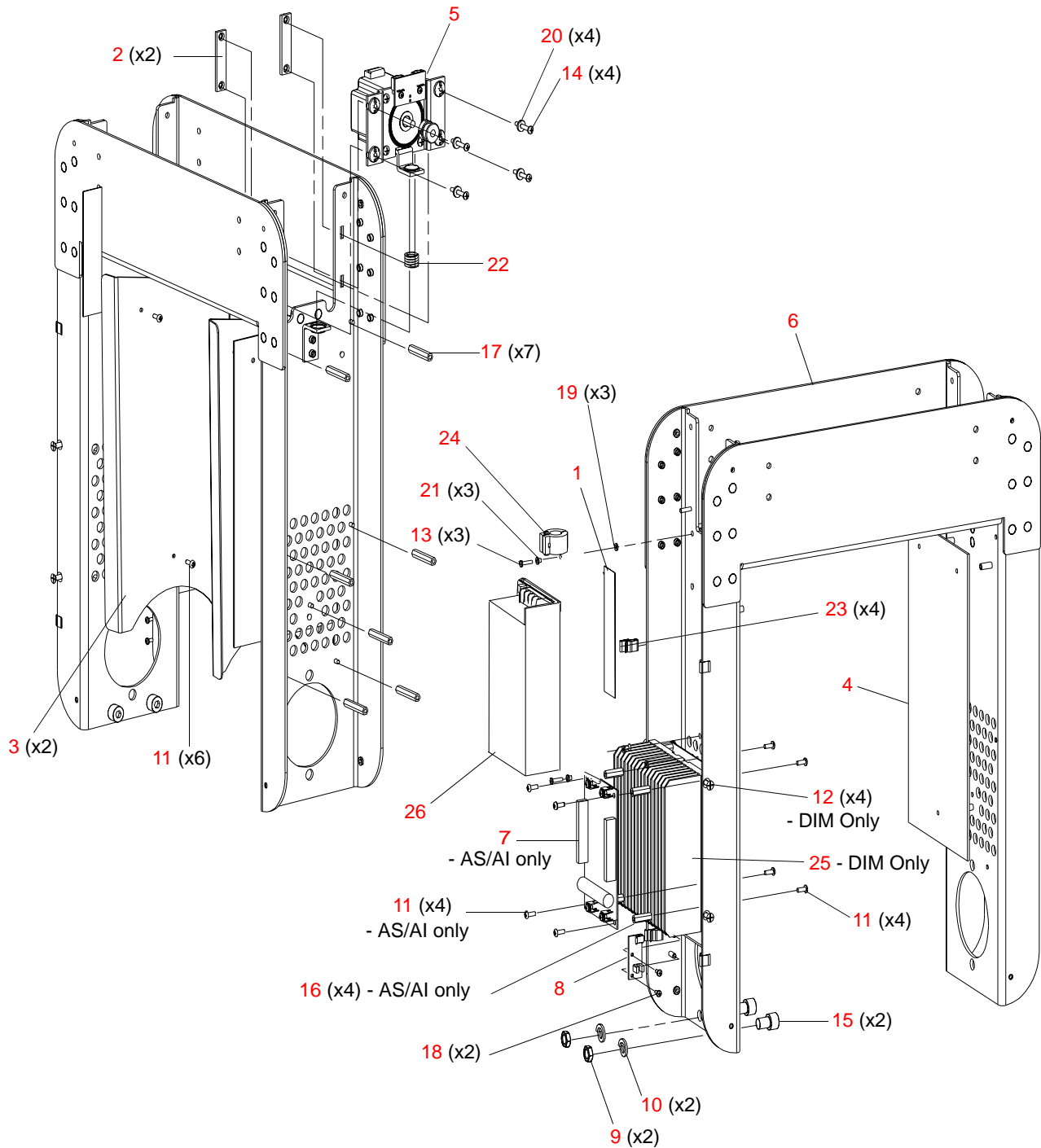

Figure 3-31: Yoke Legs Assembly

Tilt Motor Assembly

21.9663.1816 Rev D

Refer to [Figure 3-32](#).

No.	Item	Qty.	UM.	Description
1	10.9663.1825	1	EA	MOUNT, MOTOR TILT
2	21.9663.1818	1	EA	ASSY, DRIVE PULLEY
	- 10.9663.1810	1	EA	PULLEY, DRIVING - PAN/TILT
	- 10.9663.8820	1	EA	CODEWHEEL
	- 53.5561.0250	2	EA	SCREW, 6-40 X 1/4" SET CONE POINT
3	24.9661.9629	1	EA	PCB ASSY, PAN/TILT ENCODER
4	44.9663.1850	1	EA	MOTOR, 23 .81" SHAFT 12MH 6 OHM
5	53.2200.0008	4	EA	NUT, 8-32 KEPS SS
6	53.6521.0001	4	EA	SCREW, 8-32 X 1/2" PPB
7	55.2203.0001	2	EA	SCREW, 4-40 X 1/4 PPZ
8	55.6579.0015	4	EA	GROMMET, 3/8"HOLE .226"ID .125"THK VERSA-DAMP
9	55.6655.0005	4	EA	SPACER, 1/4"RND .359"LG .141"THRU ALUM

Tilt Motor Assembly (continued)

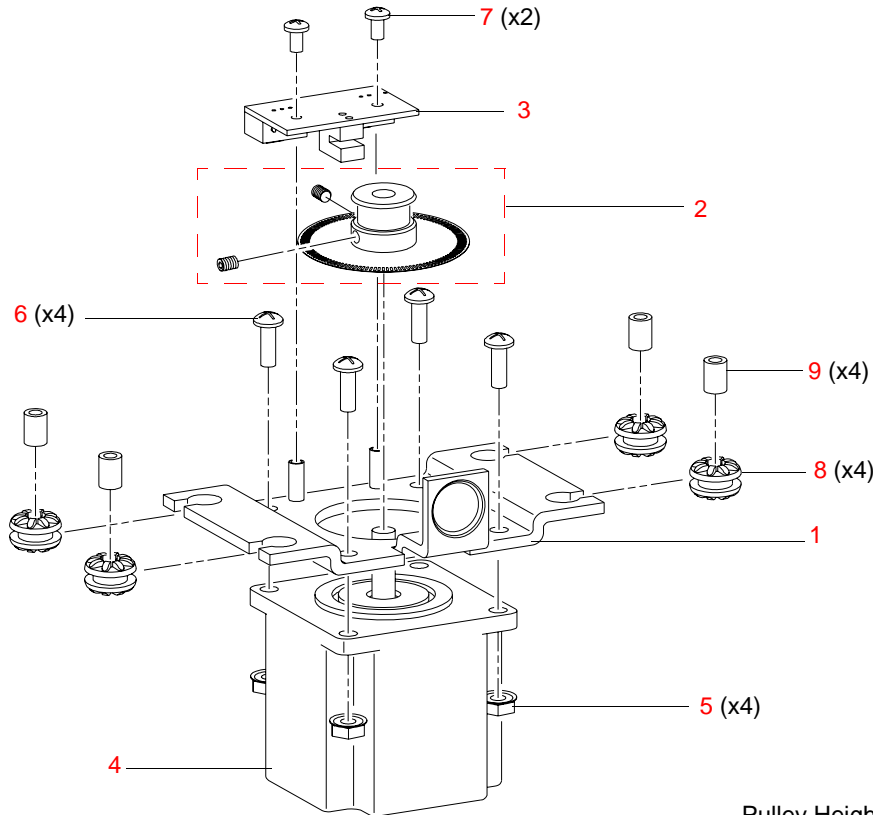

Note: Vari-Lite recommends that this assembly be replaced as a complete assembly. Although you can replace only the motor, the pulley (Item 2) is bonded to the motor shaft during assembly and cannot be removed intact. If you order a replacement motor (Item 4), also order the pulley (Item 2). Contact Vari-Lite Customer Service for installation information.

Pulley Height Detail & Installation

Step 1. Apply one drop of Loctite 603 to motor shaft.

Step 2. Install drive pulley on motor shaft using twisting motion to insure coverage of shaft with loctite.

Step 3. Do not allow Loctite to drip into motor bearing.

Step 4. Set pulley height as shown above.

Step 5. Apply Loctite 242 to pulley set screws. Insure set screws are aligned and tightened on flat sides of motor shaft.

Figure 3-32: Tilt Motor Assembly

Crossmember Assembly

21.9663.1811.01 (TS/TI) Rev J
 21.9663.1811.11 (AS/AI) Rev J
 21.9663.1811.21 (TSD/TID - 115V DIM) Rev J
 21.9663.1811.31 (TSE/TIE - 240V DIM) Rev J

Refer to [Figure 3-33](#).

No.	Item	Qty.	UM.	Description
1	10.9663.1808	1	EA	TOGGLE, PAN
2	10.9663.1809	1	EA	ACTUATOR, TOGGLE PAN
3	10.9663.1821	1	EA	COVER, PAN TUBE
4	10.9663.1827	2	EA	NUT PLATE, PAN/TILT MOTOR
5	10.9663.1844	1	EA	SHIELD, WIRE PAN
6	10.9663.1846	1	EA	TETHER, PAN TUBE SAFETY
7	10.9663.1890	1	EA	PULLEY, PAN (changed 12-13-02)
8	21.9663.1812	1	EA	ASSY, INNER CROSSMEMBER
9	21.9663.1813	1	EA	ASSY, OUTER CROSSMEMBER
10	21.9663.1815	1	EA	ASSY, PAN MOTOR
11	21.9663.1819.01	1	EA	ASSY, PAN TUBE (TS/TI ONLY)
	21.9663.1819.11	1	EA	ASSY, PAN TUBE (AS/AI ONLY)
	21.9663.1819.21	1	EA	ASSY, PAN TUBE (115V DIMMER) (added 08-25-03)
	21.9663.1819.31	1	EA	ASSY, PAN TUBE (240V DIMMER) (added 08-25-03)
12	24.9663.3230	1	EA	PCB ASSY, WHEEL SENSOR
-	25.9663.2001	1	EA	CABLE ASSY, PAN EOT - NOT SHOWN
13	53.2020.0001	1	EA	NUT, 1/4-20 HEX STL ZINC PLTD
14	53.5509.1375	1	EA	SCREW, 8-32 X 3/8" PPZ TYPE F
15	53.6505.0009	1	EA	BOLT, 1/4-20 X 2 1/2" HX HD CAP ZINC
16	53.6552.0001	6	EA	SCREW, 8-32 X 1/2" PFZ
17	53.6556.0006	4	EA	SCREW, 4-40 X 3/8" LG PPZ TYPE F
18	53.6575.0020	14	EA	SCREW, 8-32 X 3/8" LG PFZ TYP-F THRD CUTNG
19	53.6617.0001	4	EA	SCREW, 6-32 X 1" PPB
20	54.1206.0014	3	EA	RING, RETAINING 1.375" SHAFT 1.291" GRV DIA .056" GRVWD EXTERNAL
21	54.2047.0024	1	EA	BELT, TIMING GT 3MM PITCH 150GRV 6MM WD NEOPRENE
22	55.2203.0001	2	EA	SCREW, 4-40 X 1/4 " PPZ
23	55.3301.0006	4	EA	WASHER, #6 FLAT SS
24	55.6563.0001	3	EA	SCREW, 10-32 X 1/4" PPZ
25	55.6568.0055	1	EA	SPRING, CPRSN .240"OD .813"LG .038" WIRE DIA MUSIC WIRE

No.	Item	Qty.	UM.	Description
26	55.6799.0001	1	EA	SHIM, 1.375" ID, 1.875" OD, 0.010" THK
27	55.6799.0002	1	EA	SHIM, 1.375" ID, 1.875" OD, 0.005" THK

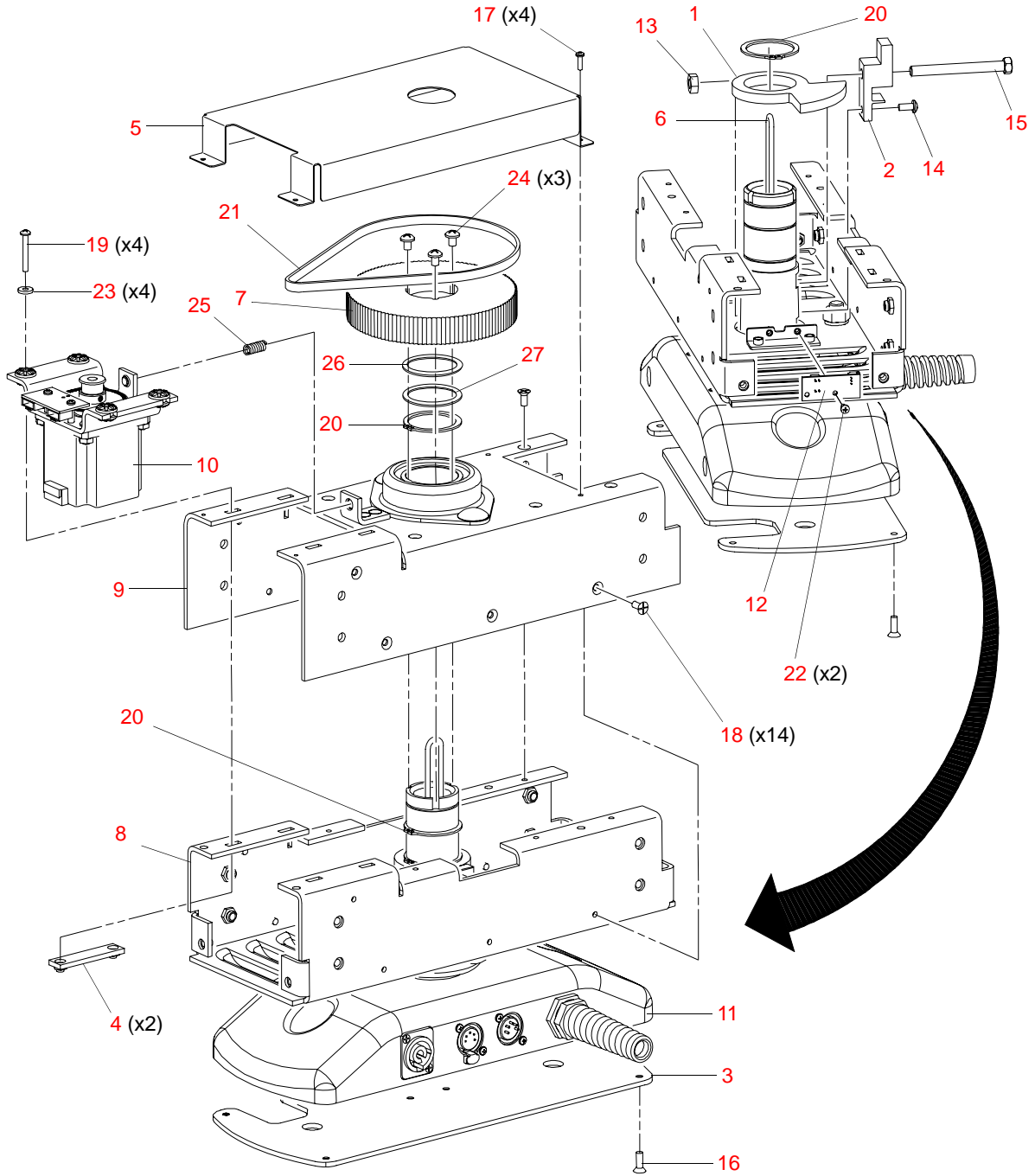

Figure 3-33: Crossmember Assembly

Inner Crossmember Assembly

21.9663.1812 Rev D

Refer to [Figure 3-34](#).

No.	Item	Qty.	UM.	Description
1	10.9663.1805	1	EA	CROSSMEMBER, INNER
2	10.9678..0886	1	EA	SPACER, PAN BEARING .235" THK
3	53.2019.0001	2	EA	NUT, 3/8-16 HEX
4	53.6505.0022	2	EA	BOLT, 3/8-16 X 3/4"LG CARRIAGE GRD5 ZINC PLT
5	53.6539.0001	2	EA	WASHER, 3/8" SPLIT LOCK
6	54.1255.0002	1	EA	BEARING ASSY, FLUSH MOUNT HOUSING LARGE

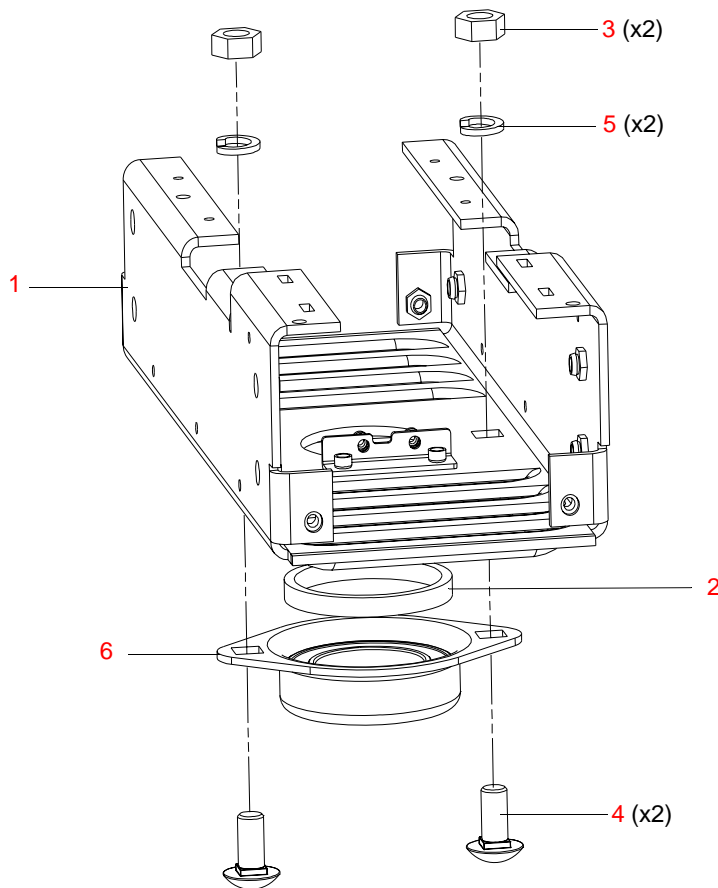

Figure 3-34: Crossmember Inner Assembly

Outer Crossmember Assembly

21.9663.1813 Rev C

Refer to [Figure 3-35](#).

No.	Item	Qty.	UM.	Description
1	10.9663.1897	1	EA	SPACER, PAN BEARING
2	21.9663.1843	1	EA	ASSY, CROSSMEMBER OUTER
3	53.2019.0001	2	EA	NUT, 3/8-16 HEX
4	53.6505.0022	1	EA	BOLT, 3/8-16 X 3/4"LG CARRIAGE GRD5 ZINC PLT
5	53.6505.0023	1	EA	BOLT, 3/8-16 X 1 1/4"LG CARRIAGE GRD5 ZINC PLT
6	53.6539.0001	2	EA	WASHER, 3/8" SPLIT LOCK
7	54.1255.0001	1	EA	BEARING ASSY, BLACK FLUSH MOUNT HOUSING

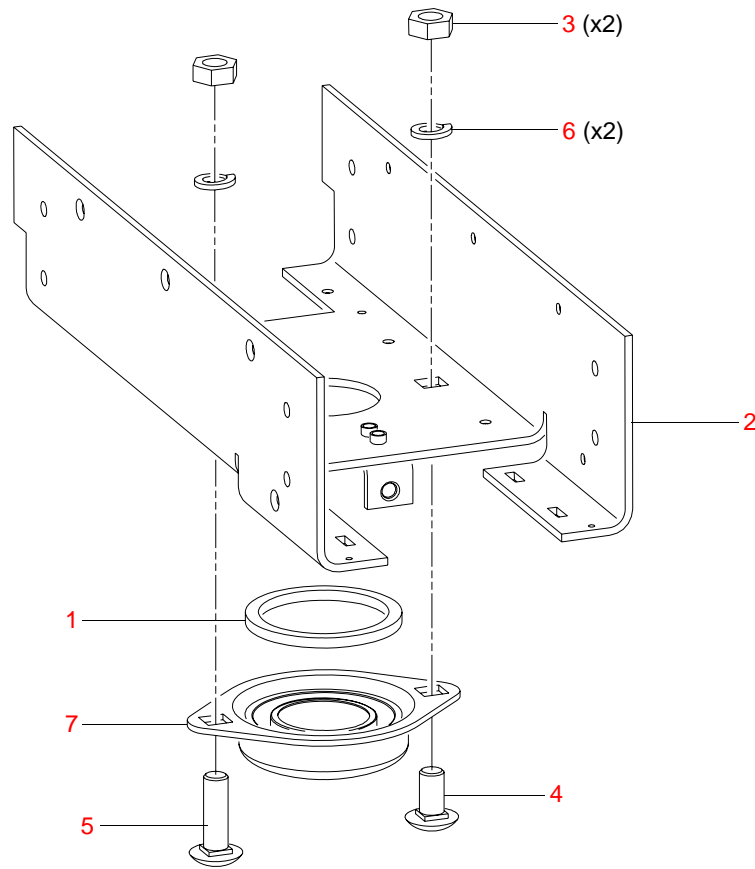

Figure 3-35: Crossmember Outer Assembly

Pan Motor Assembly

21.9663.1815 Rev D

Refer to [Figure 3-36](#).

No.	Item	Qty.	UM.	Description
1	10.9663.1817	1	EA	MOUNT, MOTOR TILT
2	21.9663.1818	1	EA	ASSY, DRIVE PULLEY
	- 10.9663.1810	1	EA	PULLEY, DRIVING - PAN/TILT
	- 10.9663.8820	1	EA	CODEWHEEL
	- 53.5561.0250	2	EA	SCREW, 6-40 X 1/4" SET CONE POINT
3	24.9661.9629	1	EA	PCB ASSY, PAN/TILT ENCODER
4	44.9663.1850	1	EA	MOTOR, 23 .81" SHAFT 12MH 6 OHM
5	53.2200.0008	4	EA	NUT, 8-32 KEPS SS
6	53.6521.0001	4	EA	SCREW, 8-32 X 1/2" PPB
7	55.2203.0001	2	EA	SCREW, 4-40 X 1/4 PPZ
8	55.6579.0015	4	EA	GROMMET, 3/8"HOLE .226"ID .125"THK VERSA-DAMP
9	55.6655.0005	4	EA	SPACER, 1/4"RND .359"LG .141"THRU ALUM

Pan Motor Assembly (continued)

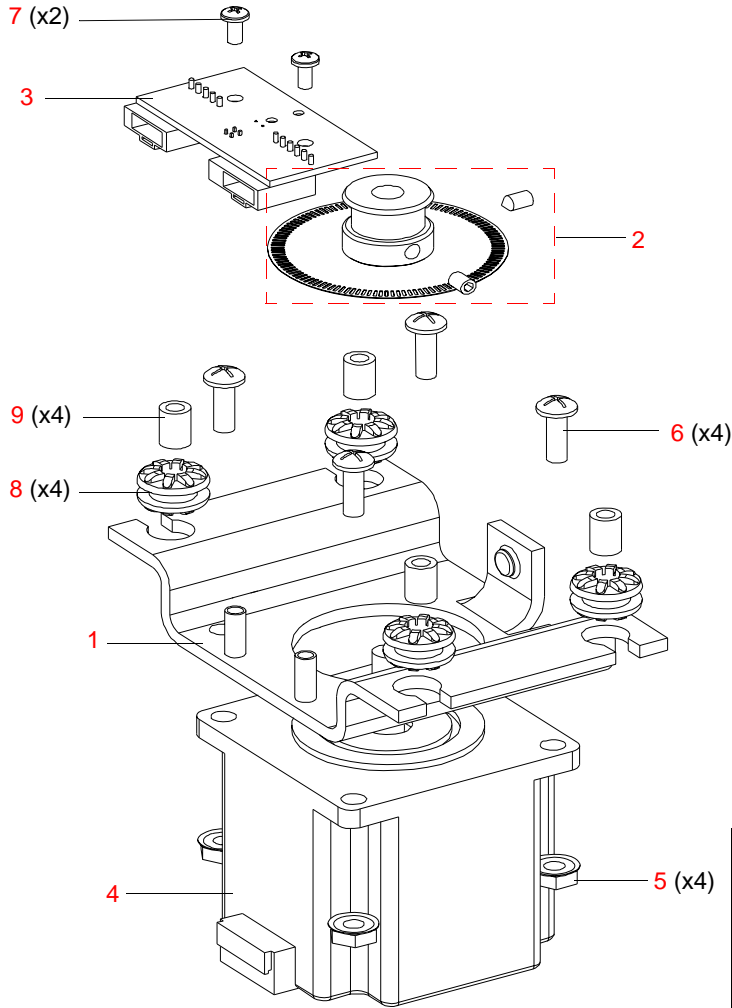

Note: Vari-Lite recommends that this assembly be replaced as a complete assembly. Although you can replace only the motor, the pulley (Item 2) is bonded to the motor shaft during assembly and cannot be removed intact. If you order a replacement motor (Item 4), also order the pulley (Item 2). Contact Vari-Lite Customer Service for installation information.

Pulley Height Detail & Installation

Step	1. Apply one drop of Loctite 603 to motor shaft.
Step	2. Install drive pulley on motor shaft using twisting motion to insure coverage of shaft with loctite.
Step	3. Do not allow Loctite to drip into motor bearing.
Step	4. Set pulley height as shown above.
Step	5. Apply Loctite 242 to pulley set screws. Insure set screws are aligned and tightened on flat sides of motor shaft.

Figure 3-36: Pan Motor Assembly

Pan Tube Assembly

21.9663.1819.01 (TS/TI) Rev P

21.9663.1819.11 (AS/AI) Rev P

21.9663.1819.21 (115V Dim) Rev P

21.9663.1819.31 (240V Dim) Rev P

Refer to [Figure 3-37](#).

No.	Item	Qty.	UM.	Description
1	04.9640.0374	1	EA	LABEL, P.E. GROUND
2	10.9663.1851	1	EA	PAN TUBE, TOP
3	24.9663.3895	1	EA	PCB ASSY, DMX INPUT
4	25.9663.1921	1	EA	CABLE ASSY, ARC POWER INPUT (PIGTAIL) (AS/AI ONLY)
5	25.9663.2015.01	1	EA	CABLE ASSY, NEUTRIK CONNECTOR, 115V
-	25.9663.2816.01	1	EA	CABLE ASSY, INC. LVS AC INPUT (TS/TI ONLY) - NOT SHOWN
-	25.9663.2816.11	1	EA	CABLE ASSY, ARC LVS AC INPUT (AS/AI ONLY) - NOT SHOWN
-	25.9663.2021	1	EA	CABLE ASSY, BALLAST CNTRL LINK (AS/AI ONLY) - NOT SHOWN
-	25.9663.2022	1	EA	CABLE ASSY, DATA I/O LINK - NOT SHOWN
6	25.9663.2030	1	EA	CABLE ASSY, STRAIN RELIEF (TS/TI ONLY)
-	25.9663.2033	1	EA	CABLE ASSY, LAMP PWR INC. (TS/TI ONLY) - NOT SHOWN
-	25.9663.2035	1	EA	CABLE ASSY, ARC PWR TO IGNITOR (AS/AI ONLY) - NOT SHOWN
7	52.8295.0002	2	EA	TERMINAL STRIP, 300V 12AWG 20A 2 POS. (AS/AI ONLY)
	52.8295.0002	1	EA	TERMINAL STRIP, 300V 12AWG 20A 2 POS. (TS/TI ONLY)
8	52.8295.1002	1	EA	SPACER, TERMINAL STRIP, 600V, 2 POS (AS/TS ONLY)
9	53.2200.0004	2	EA	NUT, 4-40 KEPS SS
10	53.2200.0006	4	EA	NUT, 6-32 KEPS SS
11	53.6536.0001	2	EA	SCREW, 4-40 X 1/2" PFZ
12	51-0541	4	EA	SCREW, 4 X 3/8"LG H/L PPZ
13	53.6558.0014	1	EA	SCREW, 6-32 X 3/4" PPZ TYPE F THD CUTTING (AS/TS ONLY)
14	53.6582.0001	2	EA	SCREW, 6-32 X 3/4" PFZ
15	55.2199.1000	0.17	FT	HEATSHRINK, 1" BLACK (AS/TS ONLY)
16	55.6662.0009	1	EA	HOLE PLUG, 7/8" HOLE DIA., BLACK (DIM ONLY)
17	67.4018.0043	1	EA	FERRITE CORE, ROUND CABLE EMI 25.9MMX28.6MM (AS/AI ONLY)
18	68.4536.0003	1	EA	CHOKES ASSY, COMON MODE (AS/AI ONLY)

Pan Tube Assembly (continued)

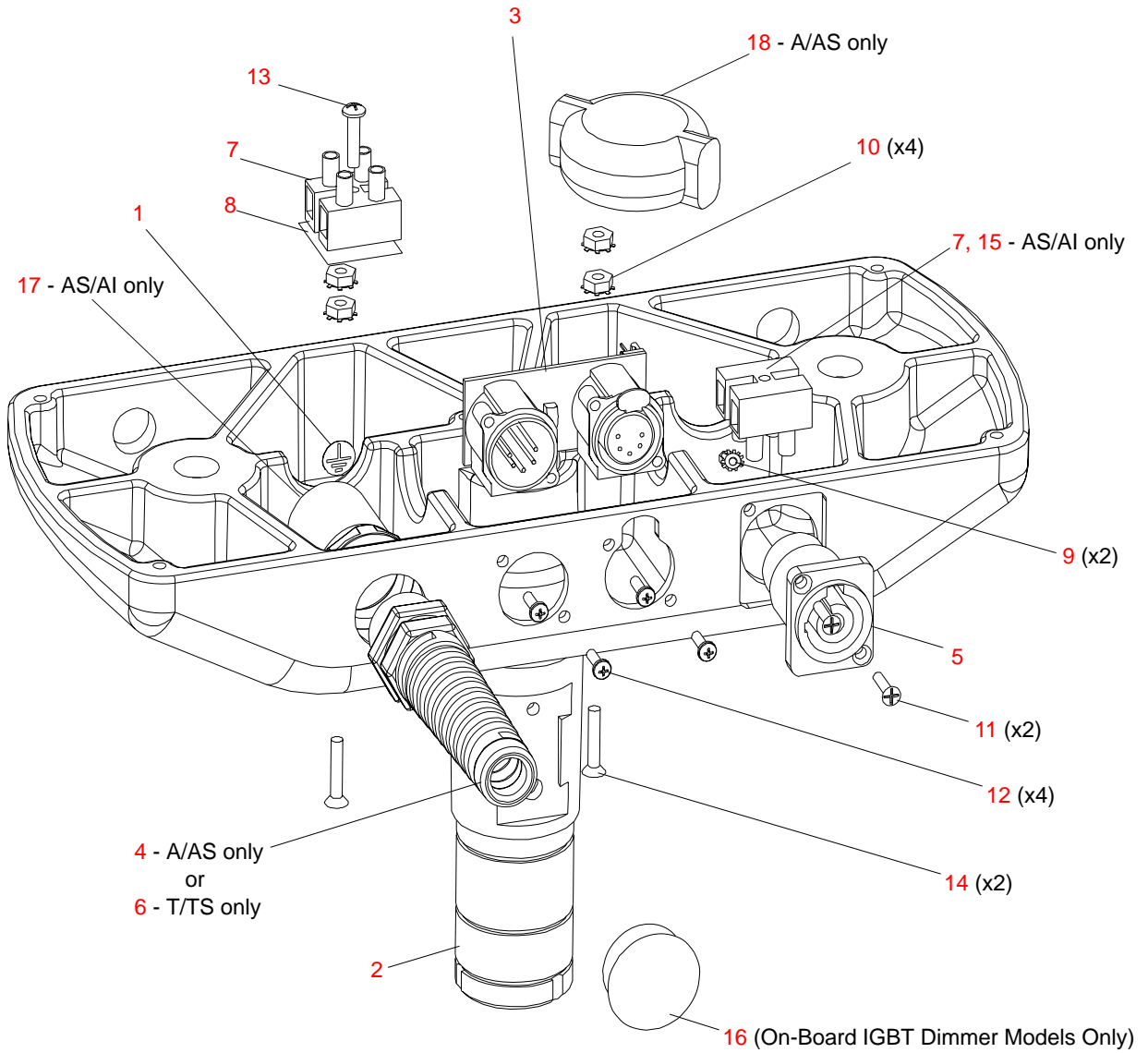

Figure 3-37: Pan Tube Assembly

DMX Input PCB Assembly

24.9663.3895 Rev 0

Refer to [Figure 3-38](#).

No.	Item	Qty.	UM.	Description	Ref
1	11.9663.1830	1	EA	PCB FAB, DMX INPUT	-
2	52.6259.0006	1	EA	HEADER, 5POS MTA FRCT LOK STRT	J3
3	52.6625.0006	1	EA	CONN, RECEPT XLR 5PIN FEMALE	J1
4	52.6626.0006	1	EA	CONN, RECEPT XLR 5PIN MALE	J2
5	62.3039.0102	1	EA	CAP, 1000PF 250V RAD CER DISC 20% X-Y	C1

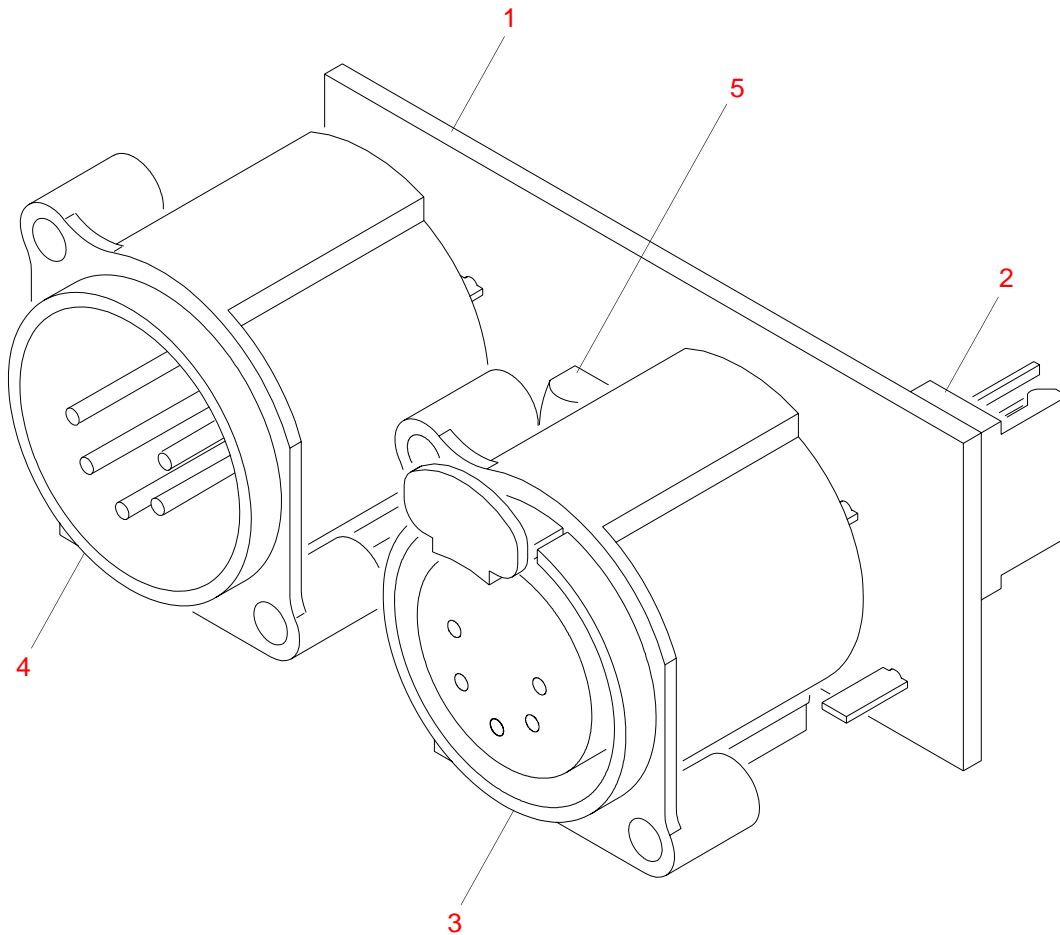

Figure 3-38: DMX Input PCB Assembly

Cables

Arc Power Input (Pigtail) Cable Assembly

25.9663.1921 Rev M

Refer to [Figure 3-39](#).

No.	Item	Qty.	UM.	Description
1	52.6274.2316	1	EA	STRAIN RELIEF, SKINTOP FLEX TYPE PG16 BLK
2	52.6400.0110	1	EA	PLUG, 17-9 STD SEX CPC 600V KEY A
3	52.6431.0002	1	EA	BACKSHELL, CPC17 NYLON .300-.525 cbl rng (changed 02-14-04)
4	52.6523.0004	1	EA	CONN, HOUSING 4POS PLUG SHROUDED WIRE TO WIRE
5	52.8210.0002	4	EA	SOCKET, GOLD 24-20AWG TYPE3+ 0.080-0.100 INS DIA
6	52.8231.0005	1	EA	TERM, RING #6 BLUE 16-14 AWG REEL PIDG
7	52.8298.1146	2	EA	FERRULE, WIRE 1X14 AWG L2=8MM BLUE
8	52.8298.1160	2	EA	FERRULE, WIRE 1X16 AWG L2=8MM BLACK
9	52.8342.0001	3	EA	SOCKET, GOLD 18-14AWG TYPE 3+ REEL 0.11-0.15 INS DIA
10	52.8344.0003	2	EA	SOCKET, CPC POWER 14AWG 13A LOOSE
11	52.8366.0001	4	EA	CONTACT, 22-24AWG MALE CRIMP
12	55.2183.0001	0.08	FT	HEATSHRINK, 1/2" BLACK
13	55.2199.0002	0.33	FT	HEATSHRINK, 1/16" CLEAR
14	73.7087.0013	4	FT	CABLE, COMPOSITE VL1000 ARC POWER INPUT

Arc Power Input Cable Assembly (continued)

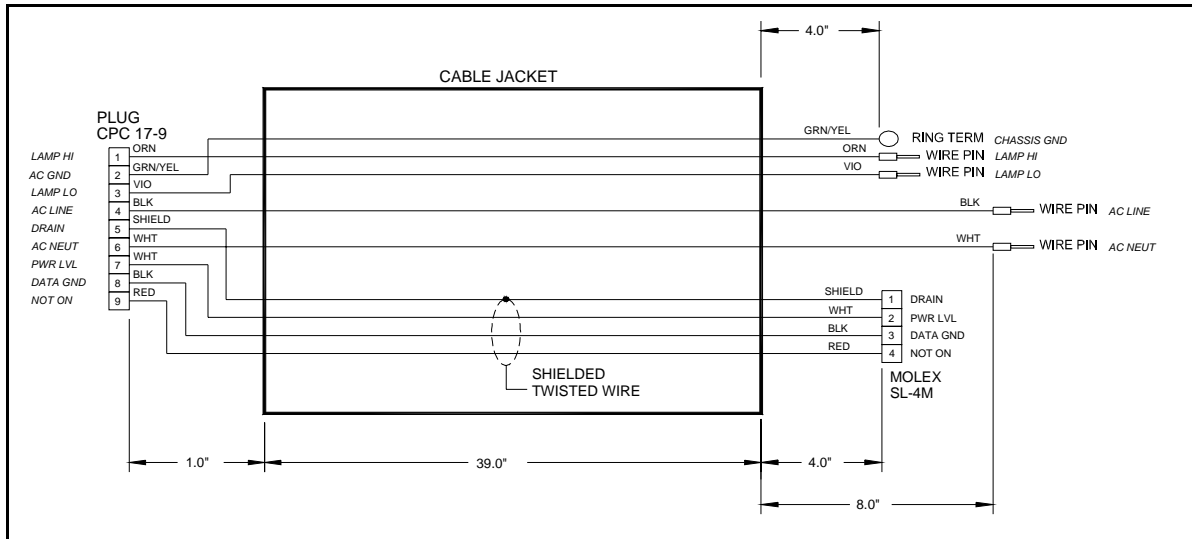
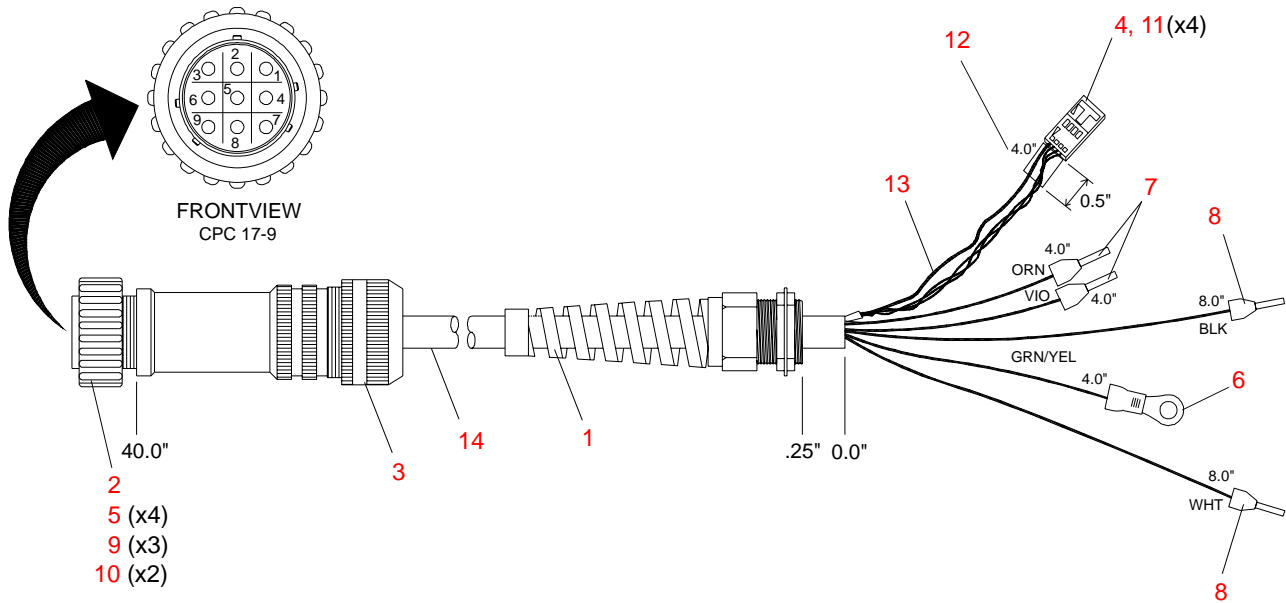

Figure 3-39: Arc Power Input (Pigtail) Cable Assembly

Pan EOT Cable Assembly

25.9663.2001 Rev A

Refer to [Figure 3-40](#).

No.	Item	Qty.	UM.	Description
1	52.6467.0003	1	EA	CONN, FEM PLUG 3 POS 30-24 AWG CRIMP PHR
2	52.6467.0024	3	EA	CONTACT, SOCKET 30-24AWG CRIMP (REEL) PH (JST)
3	52.6524.0006	1	EA	CONN, HOUSING 6POS RECEPTACLE
4	52.8346.0001	3	EA	CONTACT, 24-30AWG FEMALE CRIMP
5	73.5126.0029	1.08	FT	WIRE, 26AWG 3COND 300V 80C <BLK-RED-WHT> UL1061, 19 STRND

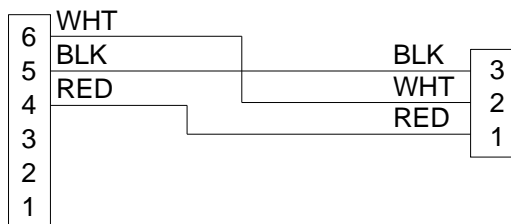
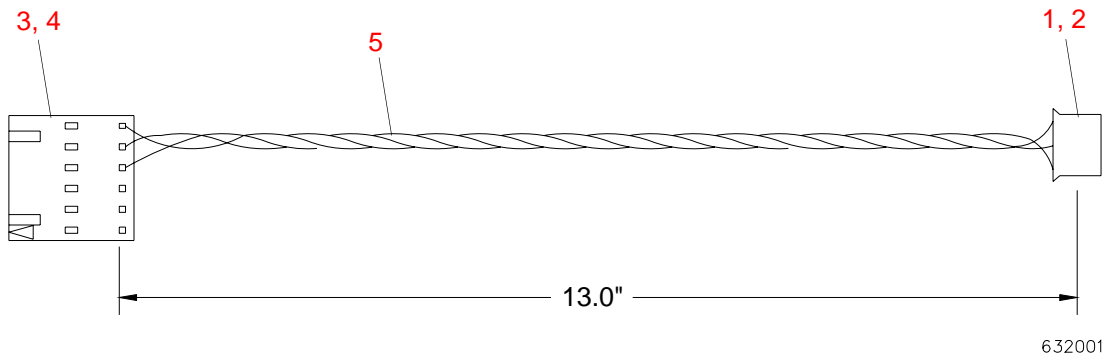

Figure 3-40: Pan EOT Cable Assembly

Tilt COT Cable Assembly

25.9663.2002 Rev A

Refer to [Figure 3-41](#).

No.	Item	Qty.	UM.	Description
1	52.6467.0003	1	EA	CONN, FEM PLUG 3 POS 30-24 AWG CRIMP PHR
2	52.6467.0024	3	EA	CONTACT, SOCKET 30-24AWG CRIMP (REEL) PH (JST)
3	52.6524.0006	1	EA	CONN, HOUSING 6POS RECEPTACLE
4	52.8346.0001	3	EA	CONTACT, 24-30AWG FEMALE CRIMP
5	73.5126.0029	2.75	FT	WIRE, 26AWG 3COND 300V 80C <BLK-RED-WHT> UL1061, 19 STRND

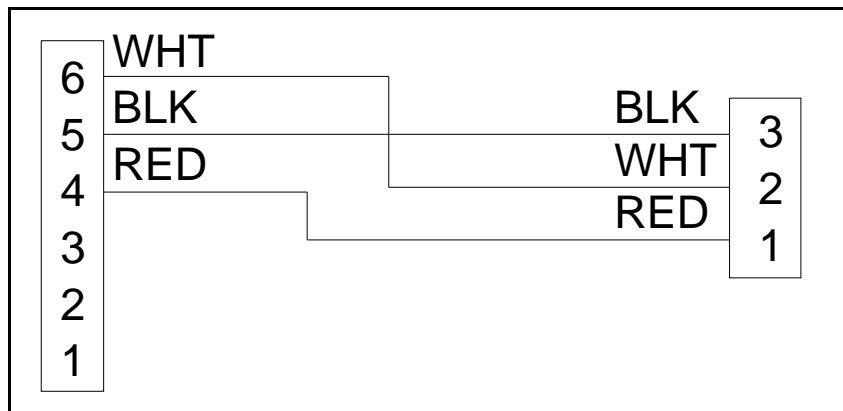
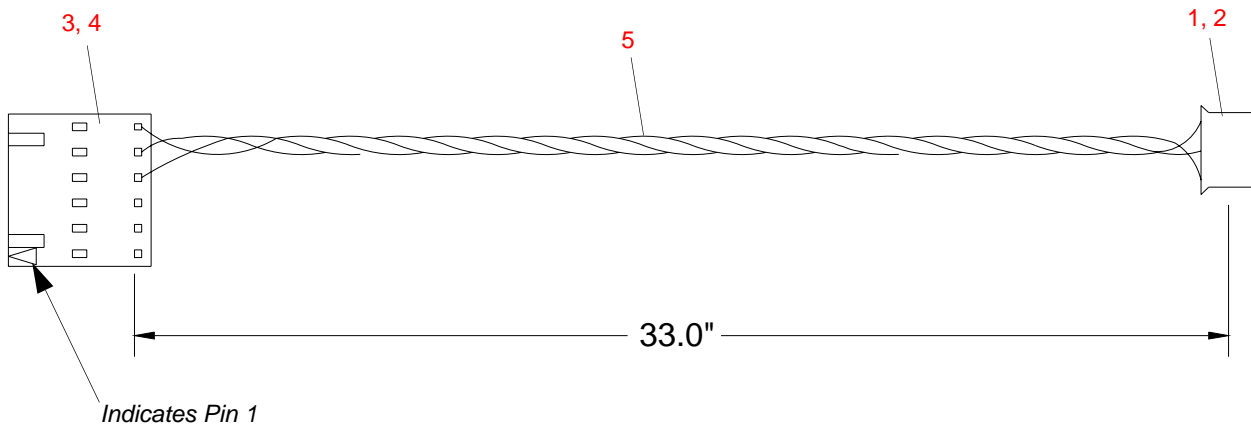

Figure 3-41: Tilt COT Cable Assembly

AC Line Input Cable Assembly

25.9663.2015.01 Rev C

Refer to [Figure 3-42](#).

No.	Item	Qty.	UM.	Description
1	52.6541.0003	1	EA	CONN, CHASSIS PWR INLET 3POLE LOCKING (115V)
2	52.8231.0005	1	EA	TERM, RING #6 BLUE 16-14 AWG REEL PIDG
3	52.8331.0003	1	EA	RECEPT, FASTON .187" 16-14AWG PIDG BLUE (REEL) .170"ID
4	73.3516.0504	0.42	FT	WIRE, 16AWG 300V 105C PVC GRN/YEL UL1569

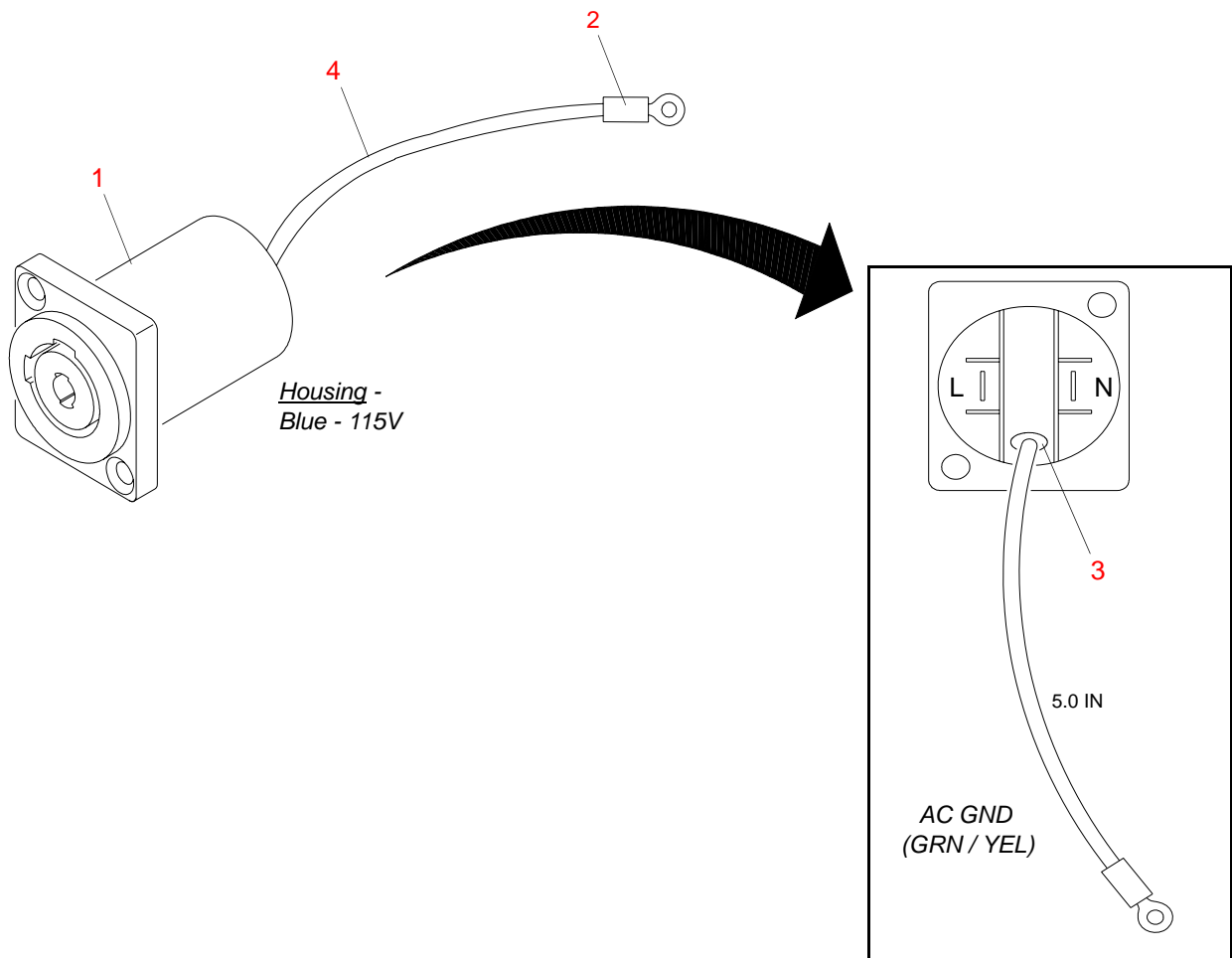

Figure 3-42: AC Line Input Cable Assembly

Incandescent LVS AC Input Cable Assembly

25.9663.2816.01 Rev B

(Formally 25.9663.2016.01 Rev 0)

Refer to [Figure 3-43](#).

No.	Item	Qty.	UM.	Description
1	52.8331.0003	2	EA	RECEPT, FASTON .187" 16-14AWG PIDG BLU .170" ID
2	52.8362.0001	4	EA	TERM, RING #6 16-14 AWG INS SMALL DIAMETER
3	55.2186.0001	3	EA	CABLE TIE, .10"WD 4.00"LG SMALL
4	73.7089.0000	12.33	FT	WIRE, 22AWG BLK 300V TEFLON STRANDED
5	73.7089.0009	12.33	FT	WIRE, 22AWG WHT TEFLON STRANDED
6	73.7089.0504	9.33	FT	WIRE, 22AWG 300V 200C TEF GRN/YEL UL1180

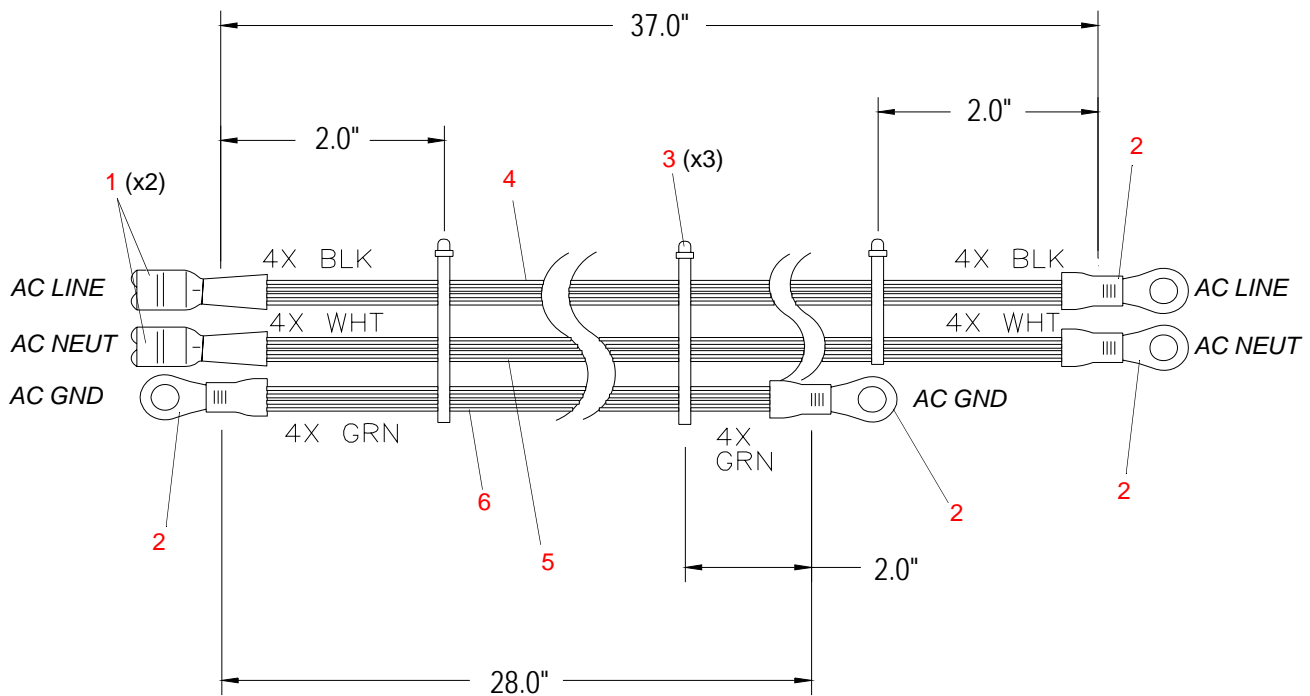

Figure 3-43: Incandescent LVS AC Input Cable Assembly

Arc LVS AC Input Cable Assembly

25.9663.2816.11 Rev B

(Formally 25.9663.2016.11 Rev 0)

Refer to [Figure 3-44](#).

No.	Item	Qty.	UM.	Description
1	52.8298.1160	2	EA	WIRE, FERRULE, 1X 16 AWG L2-8MM BLK
2	52.8362.0001	4	EA	TERM, RING #6 16-14 AWG INS SMALL DIAMETER
3	55.2186.0001	3	EA	CABLE TIE, .10"WD 4.00"LG SMALL
4	73.7089.0000	12.33	FT	WIRE, 22AWG BLK 300V TEFLON STRANDED
5	73.7089.0009	12.33	FT	WIRE, 22AWG WHT TEFLON STRANDED
6	73.7089.0504	9.33	FT	WIRE, 22AWG 300V 200C TEF GRN/YEL UL1180

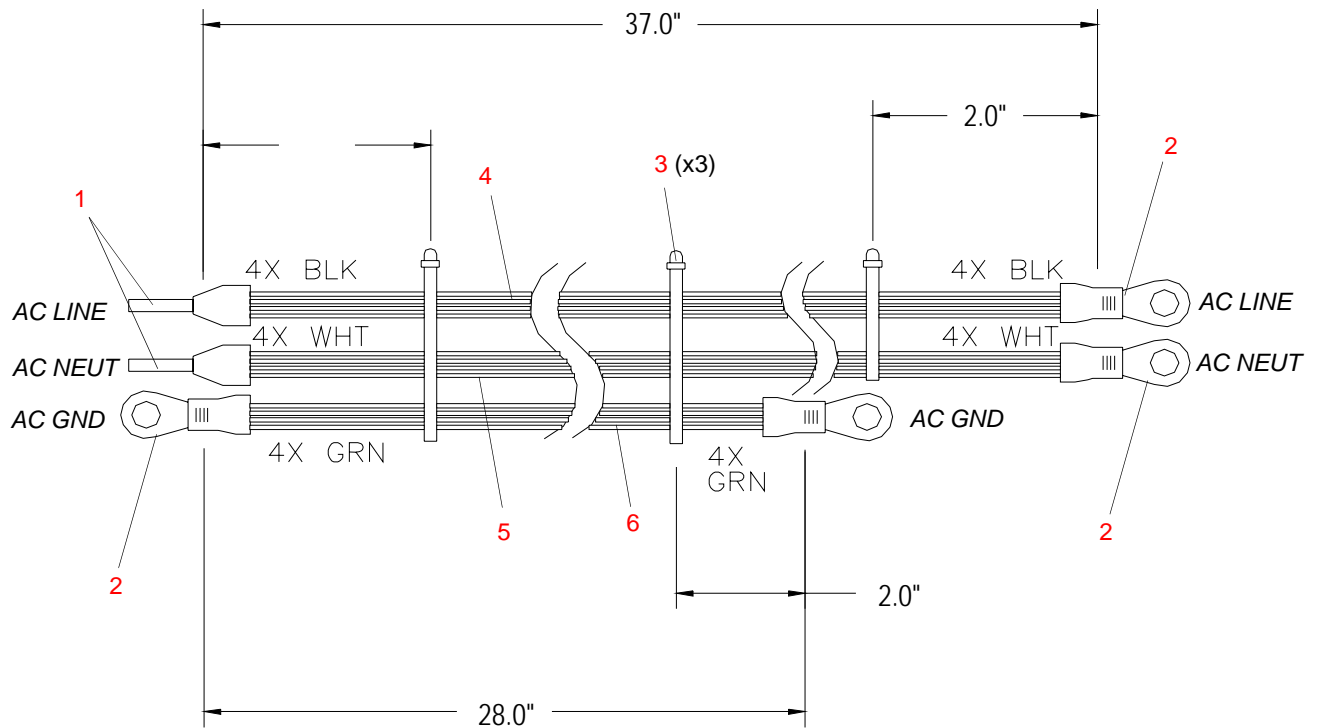

Figure 3-44: Arc LVS AC Input Cable Assembly

LVS Chassis Ground Cable Assembly

25.9663.2817 Rev B

(Formaly 25.9663.2017 Rev B)

Refer to [Figure 3-45](#)

No.	Item	Qty.	UM.	Description
1	52.8362.0001	2	EA	TERM, RING #6 BLUE 16-14 AWG SMALL DIAMETER
2	73.3516.0504	1.0	FT	WIRE, 16AWG 300V 105C PVC GRN/YEL UL1569 (changed 09-11-03)

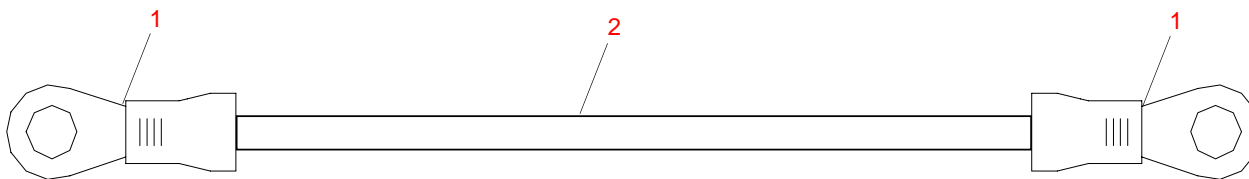

Figure 3-45: LVS Chassis Ground Cable Assembly

Head to Backcap Ground Cable Assembly

25.9663.2018 Rev G

Refer to [Figure 3-46](#).

No.	Item	Qty.	UM.	Description
1	55.2036.0001	2	EA	SLEEVE, 1/16" ROPE DIA. ALUM OVAL COMPRESSION
2	73.7188.0002	1.92	FT	WIRE ROPE, 1/16" ROPE DIA. 7X7 GALV STEEL (changed 11-19-03)

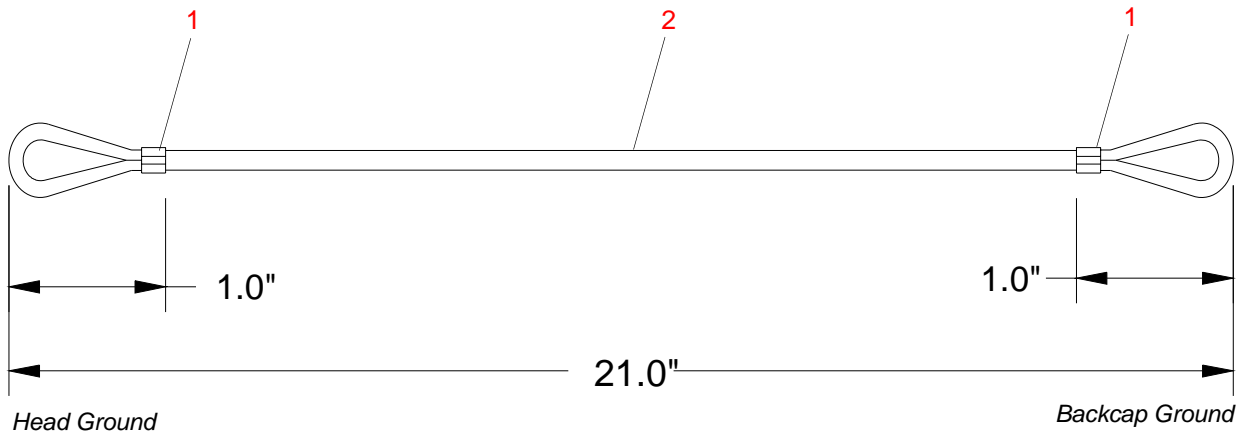

Figure 3-46: Head to Backcap Ground Cable Assembly

Yoke to Head Ground Cable Assembly

25.9663.2019 Rev B

Refer to [Figure 3-47](#).

No.	Item	Qty.	UM.	Description
1	52.8231.0005	2	EA	TERM, RING #6 BLUE 16-14 AWG REEL PIDG
2	73.7089.0504	4	FT	WIRE, 22AWG 300V 200C TEF GRN/YEL UL1180

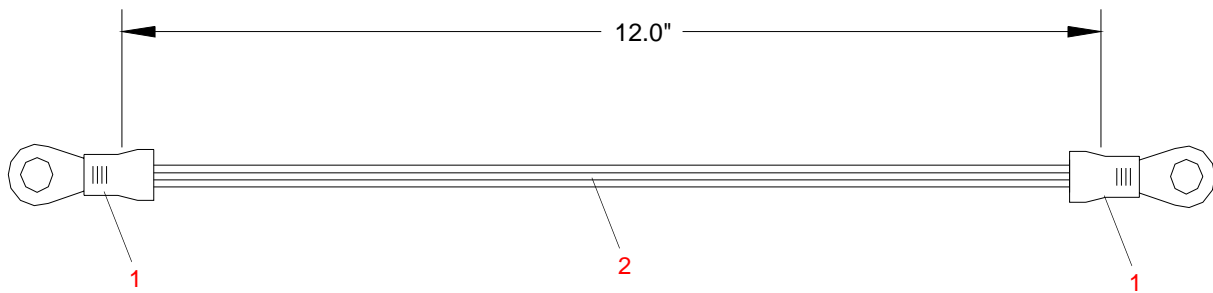

Figure 3-47: Yoke to Head Ground Cable Assembly

Pan/Tilt Control Cable Assembly

25.9663.2020 Rev B

Refer to [Figure 3-48](#).

No.	Item	Qty.	UM.	Description
1	52.6610.0008	1	EA	HOUSING, 20POS 26-22AWG UNLOADED MT RECEPT DBL ROW
	52.8351.0004	18	EA	CONTACT, 26-22 AWG RECP MTE (NOT SHOWN)
2	52.6224.1020	1	EA	COVER, FRONT 20POS MT LATCHING
3	52.6224.2020	1	EA	COVER, BACK 20POS MT
4	52.6524.0005	2	EA	CONN, HOUSING 5POS RECEPTACLE
5	52.6588.0006	2	EA	HOUSING, 6POS XH 250V/3A 2.5MMPITCH -USE SXH CONTACTS
6	52.7007.0001	8	EA	CONTACT, 28-22AWG PHOSPHOR BRONZE TIN-PLT SXH
7	52.8346.0001	10	EA	CONTACT, 24-30AWG FEMALE CRIMP
8	73.5116.0123	2.67	FT	WIRE, 24AWG 4COND TW 300V 80C <BLK-BRN-RED-ORG> UL1061
9	73.5124.1289	2.33	FT	WIRE, 24AWG 5COND 300V 80C (BLK-BRN-RED-GRY-WHT)

Pan/Tilt Control Cable Assembly (continued)

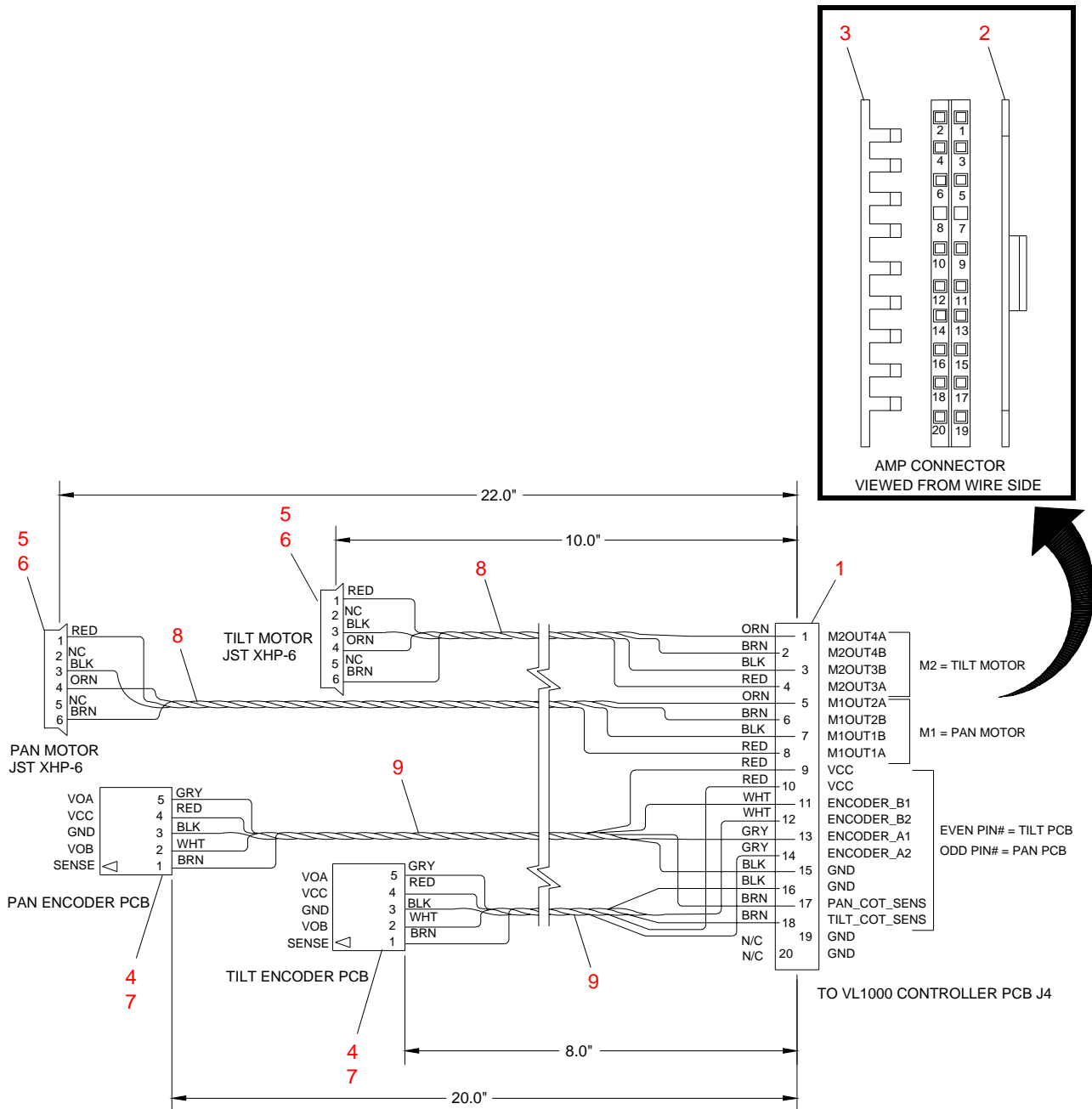

Figure 3-48: Pan/Tilt Control Cable Assembly

Ballast Control Link Cable Assembly

25.9663.2021 Rev A

Refer to [Figure 3-49](#).

No.	Item	Qty.	UM.	Description
1	53.6396.2904	1	EA	RECEPT, 4POS MTA100 W/POL TAB RED CLSD END
2	52.6524.0004	1	EA	CONN, HOUSING 4POS RECEPTACLE
3	52.8367.0001	4	EA	CONTACT, 22-24AWG FEMALE CRIMP
4	55.2186.0001	2	EA	CABLE TIE, .10"WD 4.00"LG SMALL
5	73.5122.0259	2	FT	WIRE, 22AWG 4COND 300V 80C <BLK-RED-GRN-WHT> UL1061, 19 STRAND

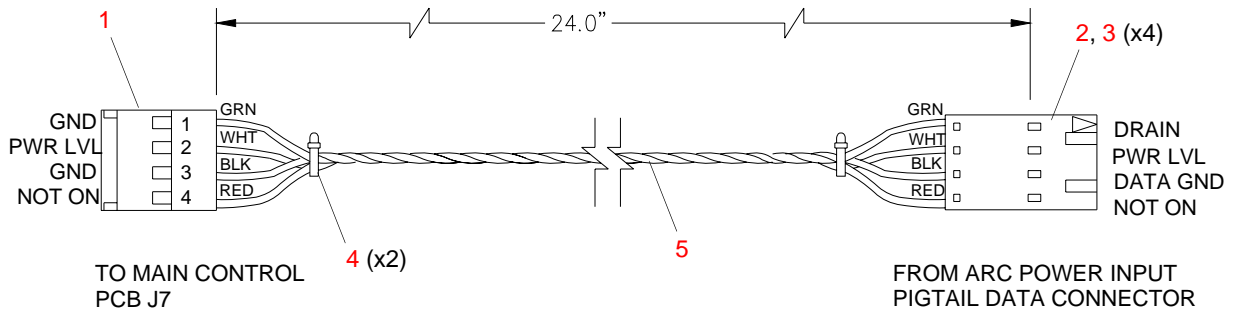

Figure 3-49: Ballast Control Link Cable Assembly

Data I/O Link Cable Assembly

25.9663.2022 Rev B

Refer to [Figure 3-50](#).

No.	Item	Qty.	UM.	Description
1	53.6396.2205	2	EA	RECEPT, 5POS MTA100 W/POL TAB RED CLSD END
2	73.5122.0259	2	FT	WIRE, 22AWG 4COND 300V 80C <BLK-RED-GRN-WHT> UL1061, 19 STRAND

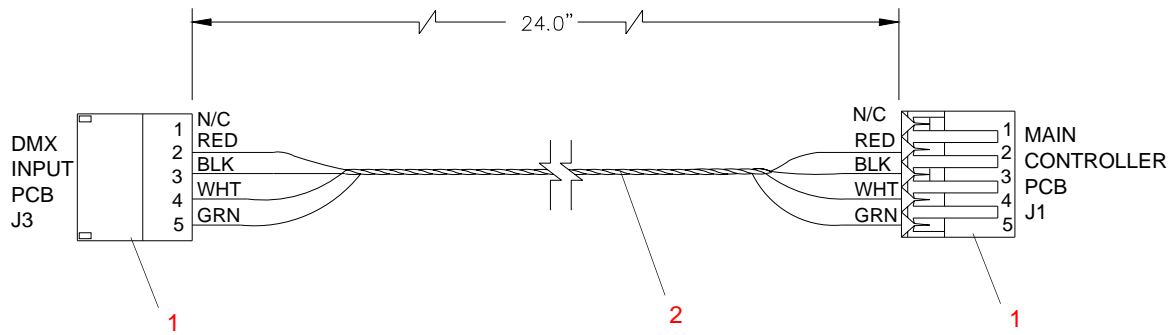

PIN	COLOR	DMX SIGNAL	VARI-LITE SIGNAL
1	N/C	-	-
2	RED	COM IN+	BDCAST+
3	BLACK	COM IN-	BDCAST-
4	WHITE	COM OUT+	REPLY+
5	GREEN	COM OUT-	REPLY-

Figure 3-50: Data I/O Link Cable Assembly

LVS DC Output Cable Assembly

25.9663.2824 Rev A

Refer to [Figure 3-51](#)

No.	Item	Qty.	UM.	Description
1	52.6442.1805	1	EA	RECEPT, MTA156 W/TAB ORN 5POS 18AWG CLOSED END
2	52.8362.0001	2	EA	TERM, RING #6 BLUE 16-14 AWG SMALL DIAMETER
3	55.2186.0001	2	EA	CABLE TIE, .10"WD 4.00"LG SMALL
4	73.3518.0002	3	FT	WIRE, 18AWG 300V 105C PVC RED UL1569
5	73.3518.0010	3	FT	WIRE, 18AWG 300V 105C PVC BLK UL1569

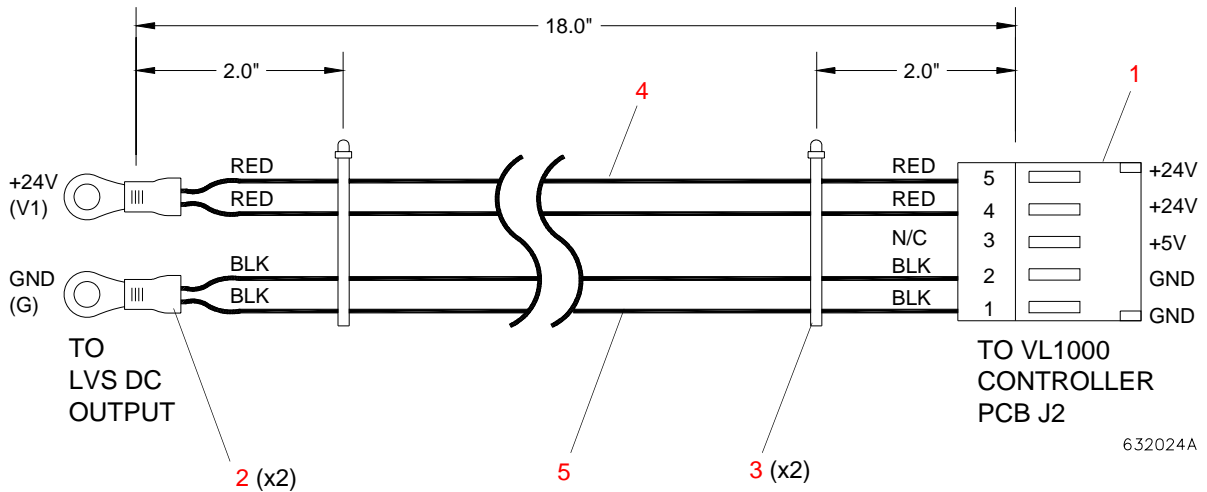

Figure 3-51: LVS DC Output Cable Assembly

Incandescent Power Input Cable Assembly

25.9663.2030 Rev A

Refer to [Figure 3-52](#).

No.	Item	Qty.	UM.	Description
1	52.6274.2313	1	EA	STRAIN RELIEF, SKINTOP FLEX TYPE PG13 BLK
2	52.8231.0005	1	EA	TERM, RING #6 BLUE 16-14 AWG REEL PIDG
3	52.8298.1160	2	EA	FERRULE, WIRE 1X16 AWG L2=8MM BLACK
4	55.2268.0187	1	FT	HEATSHRINK, 3/16" CLEAR KYNAR VDE UL 600V 150DEG C
5	55.2268.0500	0.13	FT	HEATSHRINK, 1/2" CLEAR KYNAR VDE UL 600V 150DEG C
6	73.9636.0153	4	FT	CORDAGE, 1.5/3 750V 60C EURO BLK HD-22 11MMOD

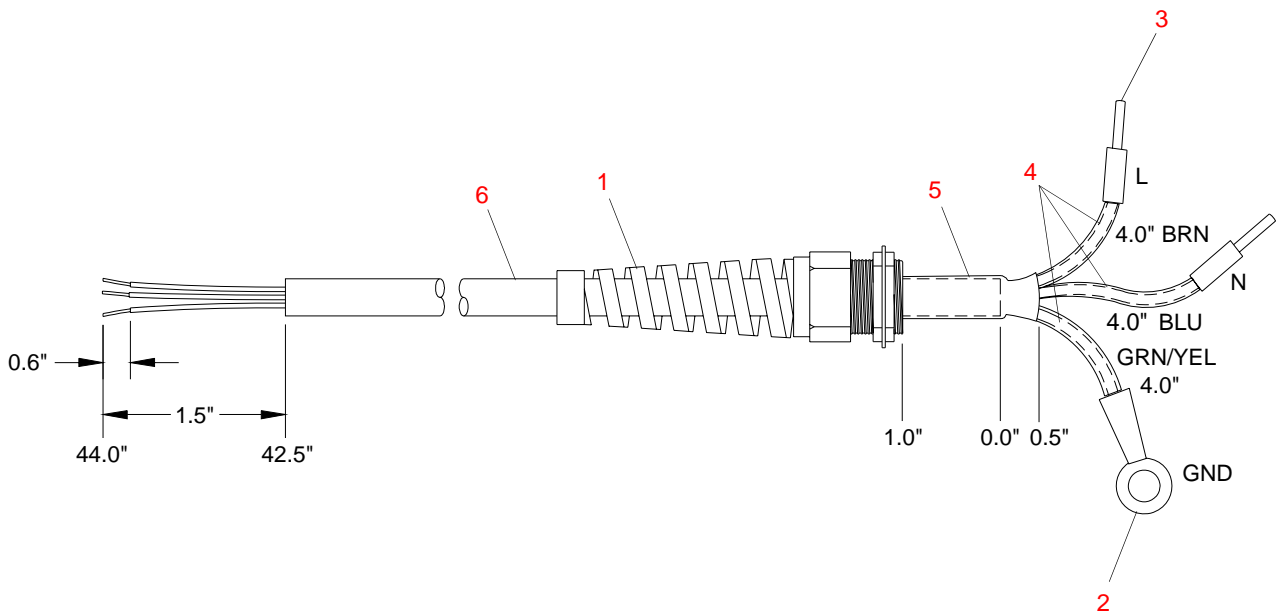

Figure 3-52: Incandescent Power Input Cable Assembly

Incandescent Lamp Power Cable Assembly

25.9663.2033 Rev G

Refer to [Figure 3-53](#).

No.	Item	Qty.	UM.	Description
1	25.9663.2018	1	EA	CABLE ASSY, HEAD TO BACKCAP GND
2	52.8298.1160	2	EA	FERRULE, WIRE 1X16 AWG L2=8MM BLACK
3	52.8386.0001	2	EA	CONN, BUTT SPLICE 16-22AWG UNISULATED SOLISTRAND
4	55.2186.0002	1	EA	CABLE TIE, .09"WD 3.750"LG TEFZEL
5	55.2200.0003	0.33	FT	HEATSHRINK, 3/16" VITON
6	55.2260.0133	4.0	FT	SLEEVING, FIBERGLASS .133" ID
7	55.2260.0294	1.75	FT	SLEEVING, FIBERGLASS .294" ID
8	73.6616.0011	3.5	FT	WIRE, 16AWG 600V 600C MICA TAPE TAN
9	73.7089.0001	16	FT	WIRE, 22AWG BRN 300V TEFLON STRANDED
10	73.7089.0006	16	FT	WIRE, 22AWG VIO TEFLON STRANDED

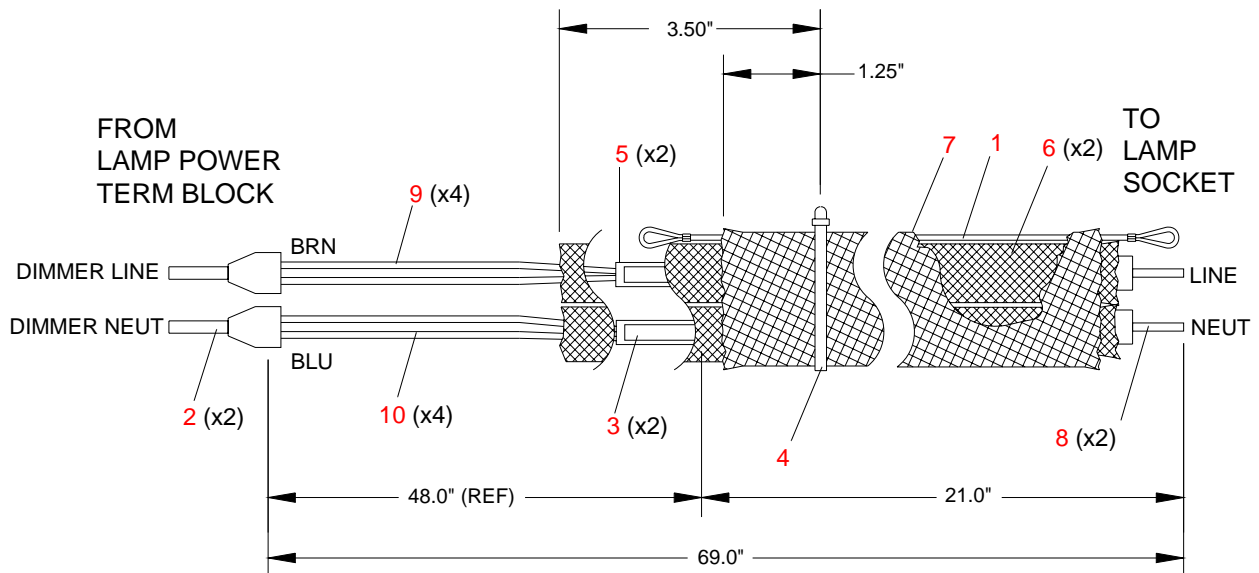

Figure 3-53: Incand Power to Lamp Socket Cable Assembly

Arc Power to Ignitor Cable Assembly

25.9663.2035 Rev C

Refer to [Figure 3-54](#).

No.	Item	Qty.	UM.	Description
1	52.8231.0005	2	EA	TERM, RING #6 BLUE 16-14 AWG REEL PIDG
2	52.8298.2160	2	EA	FERRULE, WIRE 2X16 AWG L2=8MM BLACK
3	55.2186.0001	2	EA	CABLE TIE, .10"WD 4.00"LG SMALL
4	55.6699.0003	2.67	FT	SLEEVING, 1/2"NOM.DIA. POLY EXP BRAIDED
5	73.6222.0003	12	FT	WIRE, 22AWG 600V 200C TFE ORN UL1199
6	73.6222.0007	12	FT	WIRE, 22AWG 600V 200C TFE VIO UL 1199

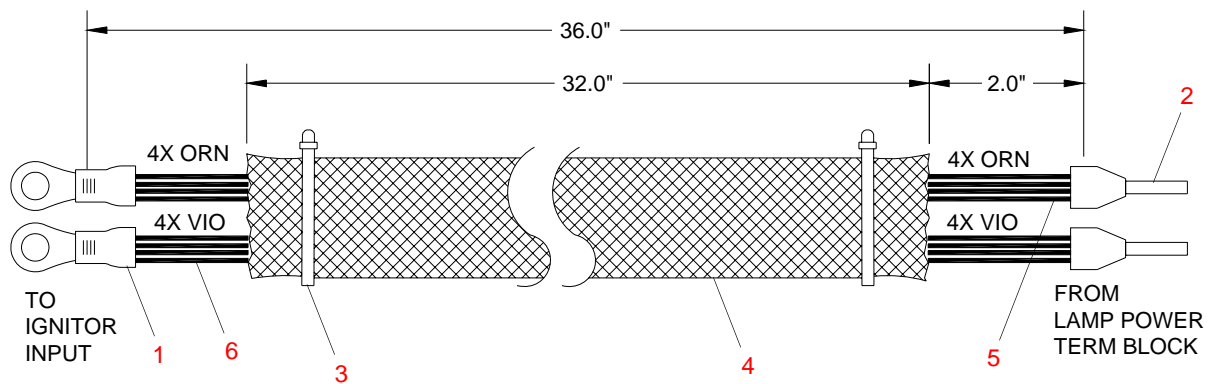

Figure 3-54: Arc Power to Ignitor Cable Assembly

Ignitor to Lamp Socket Cable Assembly

25.9663.2036 Rev H

Refer to [Figure 3-55](#).

No.	Item	Qty.	UM.	Description
1	25.9663.2018	1	EA	CABLE ASSY, HEAD TO BACKCAP GND
2	52.8231.0005	2	EA	TERM, RING #6 BLUE 16-14 AWG REEL PIDG (changed 12-13-02)
3	55.2260.0166	5.50	FT	SLEEVING, FIBERGLASS .166" ID (changed 12-13-02)
4	55.2260.0294	1.75	FT	SLEEVING, FIBERGLASS .294" ID (changed 12-13-02)
5	73.7100.0001	2.17	FT	WIRE, 16AWG 20KVDC 41/32 STRD 200C SILICONE
6	73.7190.0001	3.5	FT	WIRE, 250 DEG C
7	52.8274.1614	2	EA	CONNECTOR, BUTT SPLICE, 16-14 PIDG
8	55.2200.0003	.33	FT	HEAT SHRINK, 3/16" VITON

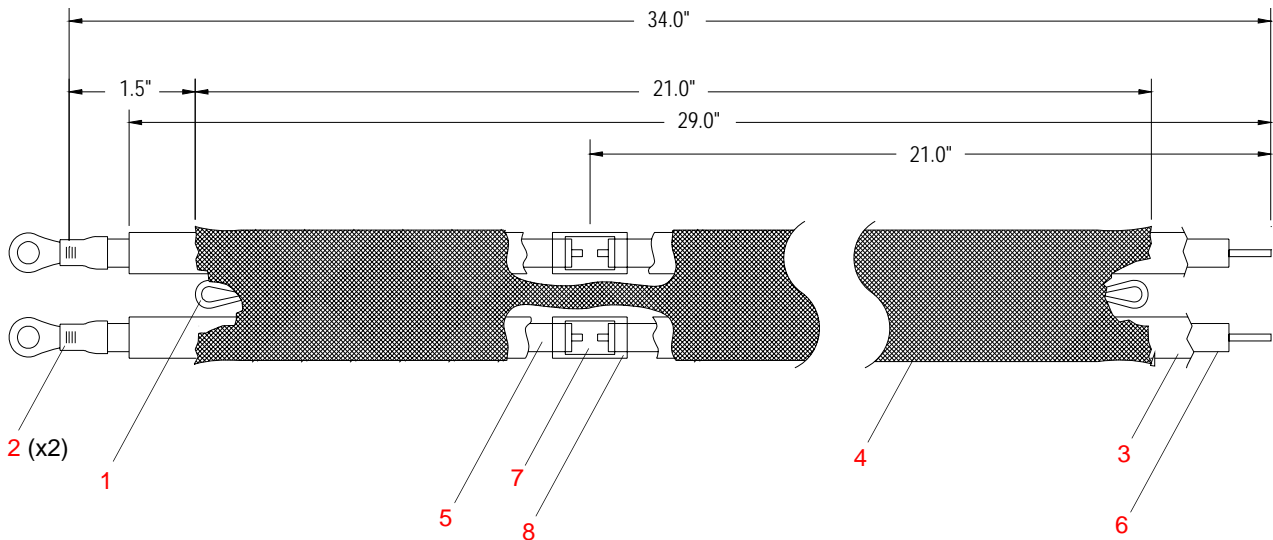

Figure 3-55: Ignitor to Lamp Socket Cable Assembly

Shutter Harness Cable Assembly

25.9663.2040 Rev F

Refer to [Figure 3-56](#) and [Figure 3-57](#).

No.	Item	Qty.	UM.	Description
1	04.9663.2040.00	1	EA	LABEL SET, SHUTTER HARNESS
2	52.6610.0040	1	EA	HOUSING, 40POS 26-22AWG UNLOADED MT RECEPT DBL ROW
	52.8351.0004	32	EA	CONTACT, 26-22 AWG RECP MTE
3	52.6224.1040	1	EA	COVER, FRONT 40POS MT LATCHING
4	52.6224.2040	1	EA	COVER, BACK 40POS MT
5	52.6661.0006	8	EA	CONN, RECEPT 6CIR WIRE TO WIRE 1.25MM PITCH
6	52.8387.0001	32	EA	CONTACT, 26-28AWG FEMALE CRIMP 1.25MM PITCH (REEL)
7	55.2186.0001	15	EA	CABLE TIE, .10"WD 4.00"LG SMALL
8	55.6699.0004	0.5	FT	SLEEVING, 3/4"NOM.DIA. POLY EXP BRAIDED
9	73.5126.0123	19.67	FT	WIRE, 26AWG 4COND TW 300V 80C (BLK-BRN-RED-ORG)

TO VL1000 CONTROLLER PCB J10

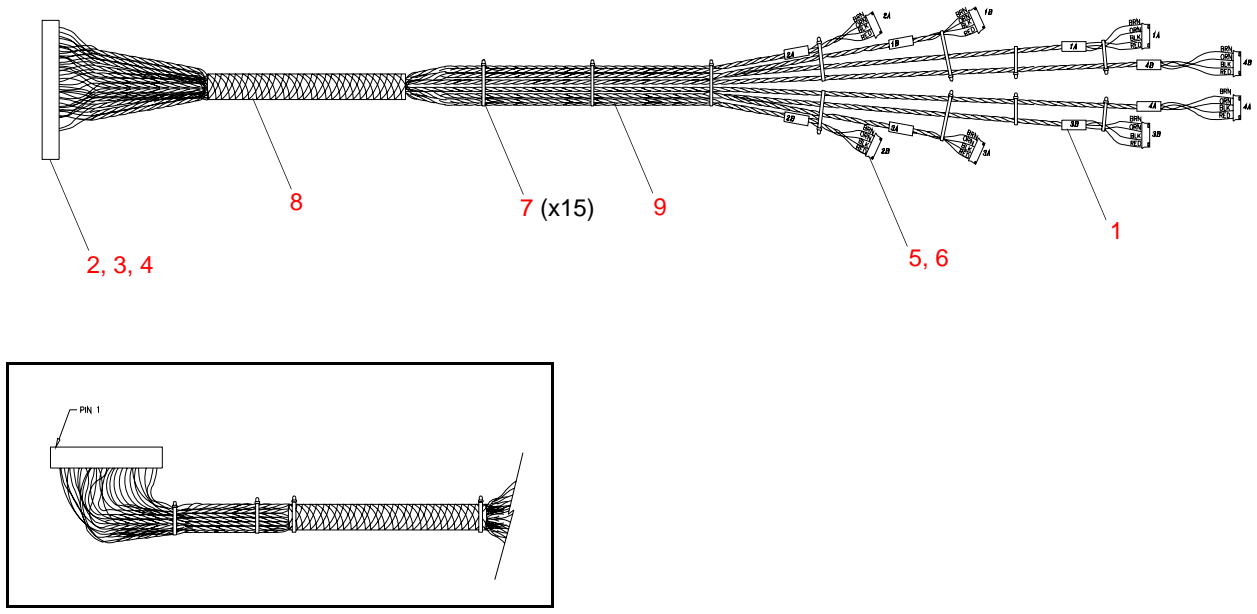

Figure 3-56: Shutter Harness Cable Assembly

Shutter Harness Cable Assembly (continued)

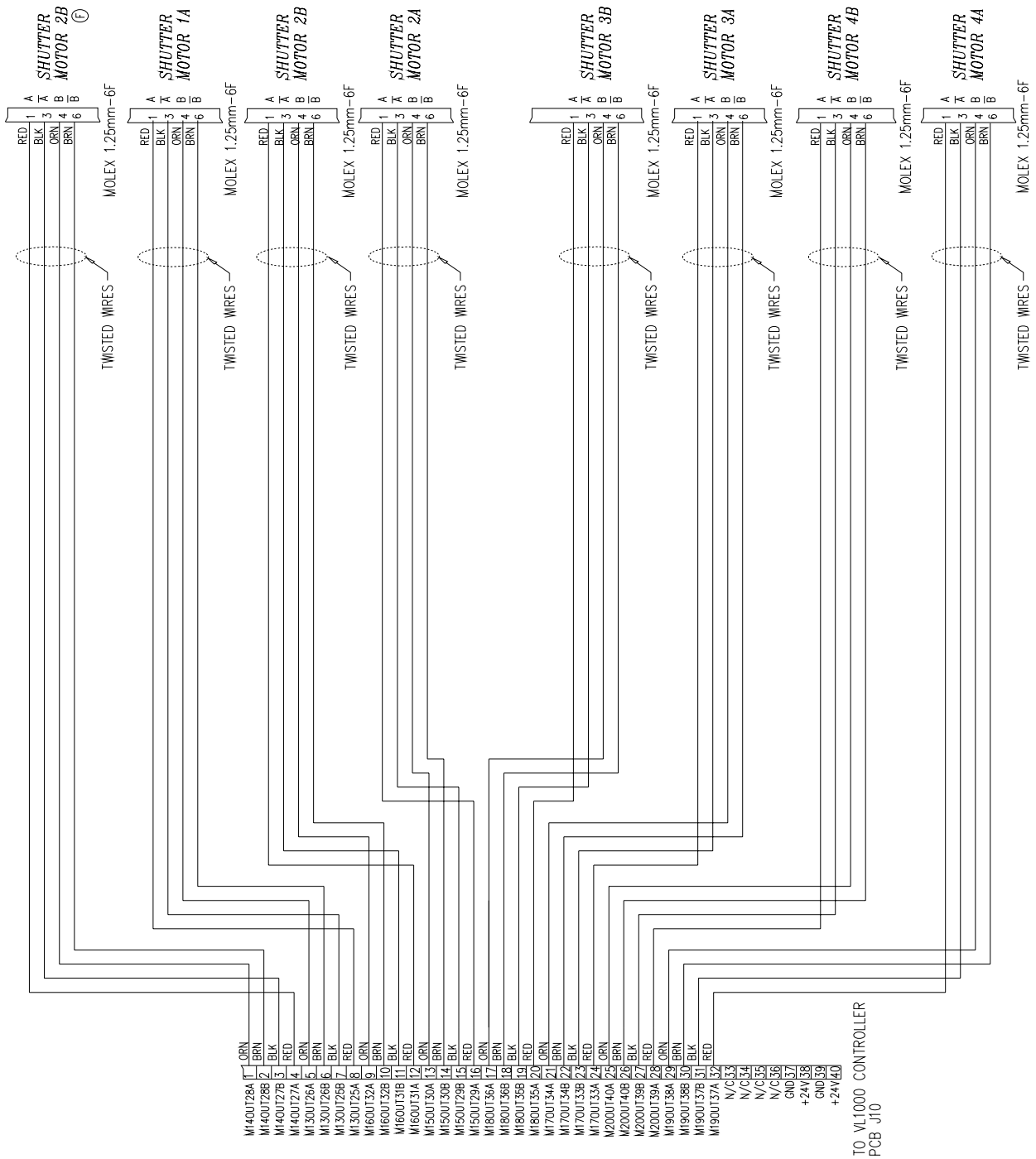

Figure 3-57: Shutter Harness Cable Assembly

Color/Gobo/Lens Harness Cable Assembly

25.9663.2050 Rev K

Refer to [Figure 3-58](#) and [Figure 3-59](#).

No.	Item	Qty.	UM.	Description
1	04.9663.2050.00	1	EA	LABEL SET, COLOR/GOBO/LENS HARNESS
2	52.6610.0017	1	EA	HOUSING, 50POS 26-22AWG UNLOADED MT RECEPT DBL ROW
	53.8351.0004	48	EA	CONTACT, 26-22 AWG RECP MTE
3	52.6224.1050	1	EA	COVER, FRONT 50POS MT LATCHING
4	52.6224.2050	1	EA	COVER, BACK 50POS MT
5	52.6467.0003	1	EA	CONN, FEM PLUG 3 POS 30-24 AWG CRIMP PHR
6	52.6467.0004	1	EA	CONN, FEM PLUG 4 POS 30-24 AWG CRIMP PHR
7	52.6467.0024	6	EA	CONTACT, SOCKET 30-24AWG CRIMP (REEL) PH (JST)
8	52.6524.0002	1	EA	CONN, HOUSING 2POS RECEPTACLE
9	52.6524.0004	1	EA	CONN, HOUSING 4POS RECEPTACLE
10	52.6661.0006	4	EA	CONN, RECEPT 6CIR WIRE TO WIRE 1.25MM PITCH
11	52.6662.0006	6	EA	HOUSING, 6POS 125V/2A 2.00MMPITCH
12	52.8346.0001	6	EA	CONTACT, 24-30AWG FEMALE CRIMP
13	52.8387.0001	16	EA	CONTACT, 26-28AWG FEMALE CRIMP 1.25MM PITCH (REEL)
14	52.8388.0001	24	EA	CONTACT, 24-30AWG FEMALE CRIMP 2.00MMPITCH (REEL)
15	55.2186.0001	12	EA	CABLE TIE, .10"WD 4.00"LG SMALL
16	55.6699.0004	0.50	FT	SLEEVING, 3/4"NOM.DIA. POLY EXP BRAIDED
17	73.5116.0123	14.25	FT	WIRE, 24AWG 4COND TW 300V 80C <BLK-BRN-RED-ORG> UL1061
18	73.5126.0002	2.67	FT	WIRE, 26AWG 2COND 300V 80C <BLK-RED> UL1061, 19STRND
19	73.5126.0029	5.92	FT	WIRE, 26AWG 3COND 300V 80C <BLK-RED-WHT> UL1061, 19STRND
20	73.5126.0123	11.42	FT	WIRE, 26AWG 4COND TW 300V 80C (BLK-BRN-RED-ORG)
21	73.7094.0001	.17	FT	WIRE, 26AWG, TEFLON, RED, 19 STRAND

Color/Gobo/Lens Cable Assembly (continued)

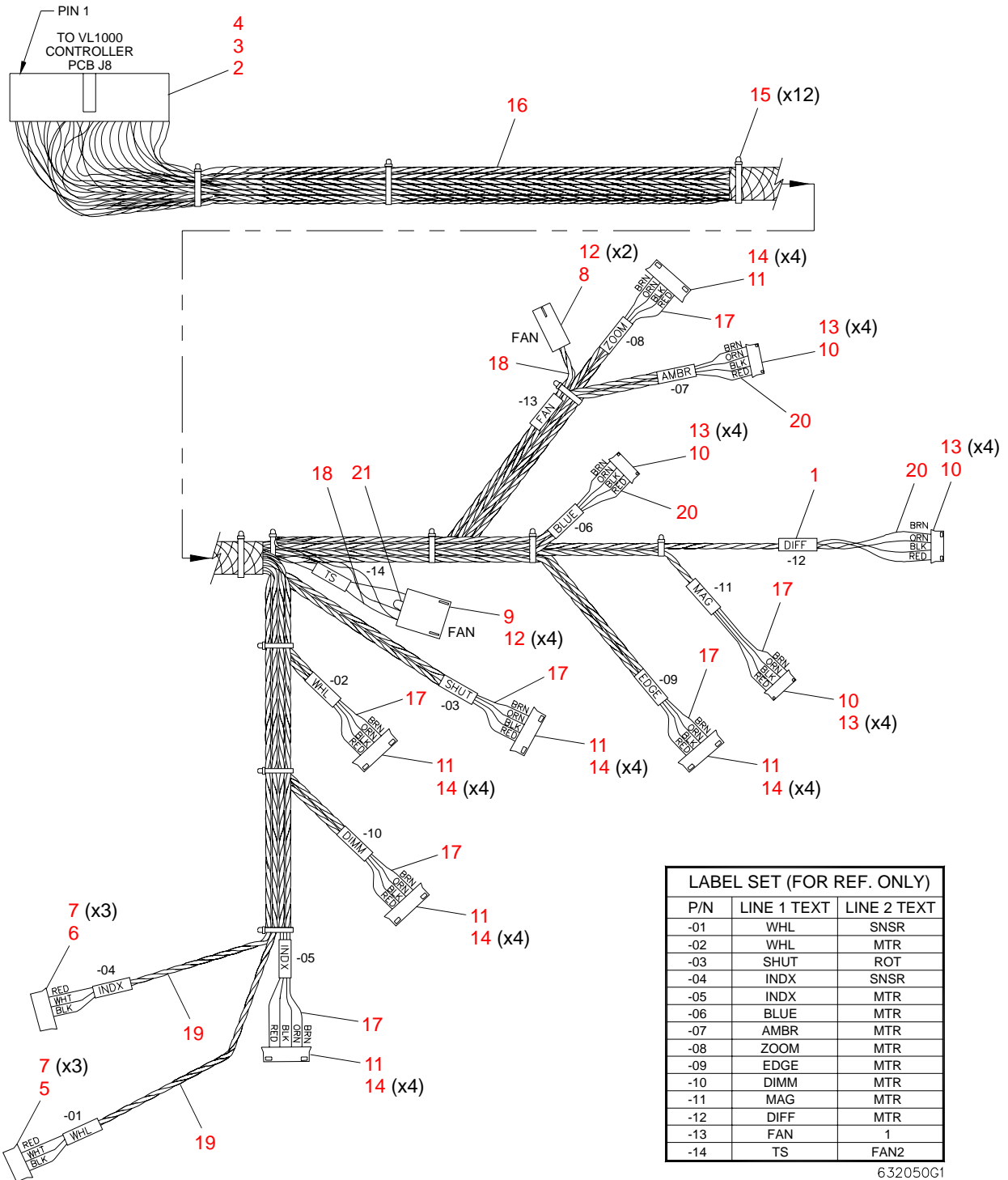

Figure 3-58: Color/Gobo/Lens Harness Cable Assembly

Color/Gobo/Lens Cable Assembly (continued)

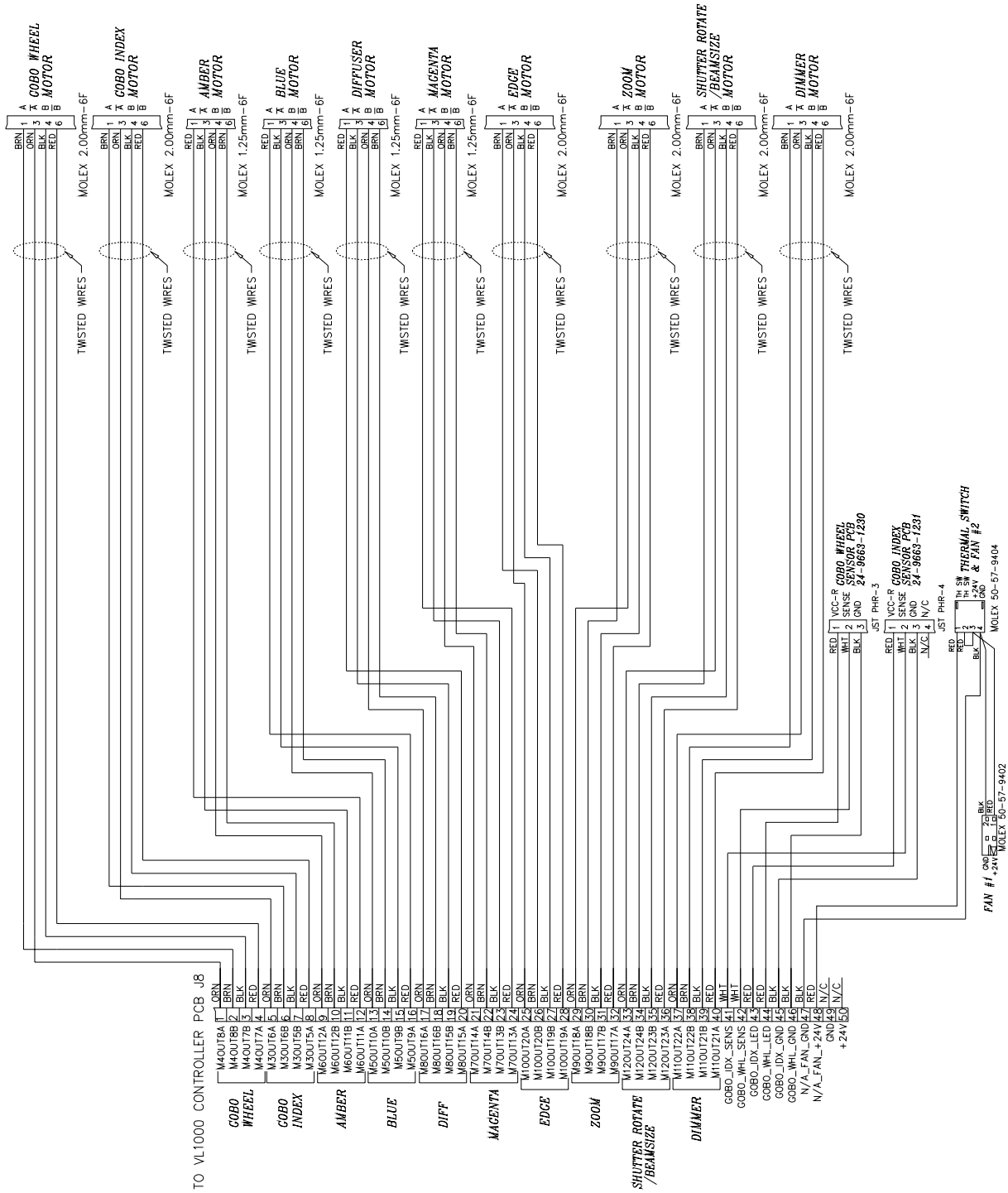

Figure 3-59: Color/Gobo/Lens Harness Cable Assembly

Dimmer to LVS Cable Assembly

25.9663.2826 Rev A

Refer to [Figure 3-60](#).

No.	Item	Qty.	UM.	Description
1	52.8313.0001	2	EA	RECEPT, FASTON 1/4" 18-14 AWG FLAG DBL CRIP
2	52.8362.0001	2	EA	TERM, RING #6 BLUE 16-14 AWG INS SMALL DIAM
3	55.2186.0001	1	EA	CABLE TIE, .10" X 4" SMALL
4	73.6016.0009	1.5	FT	WIRE, 16 AWG 600V 105C PVC WHT UL1015
5	73.6016.0010	1.5	FT	WIRE, 16 AWG 600V 105C PVC BLK UL1015

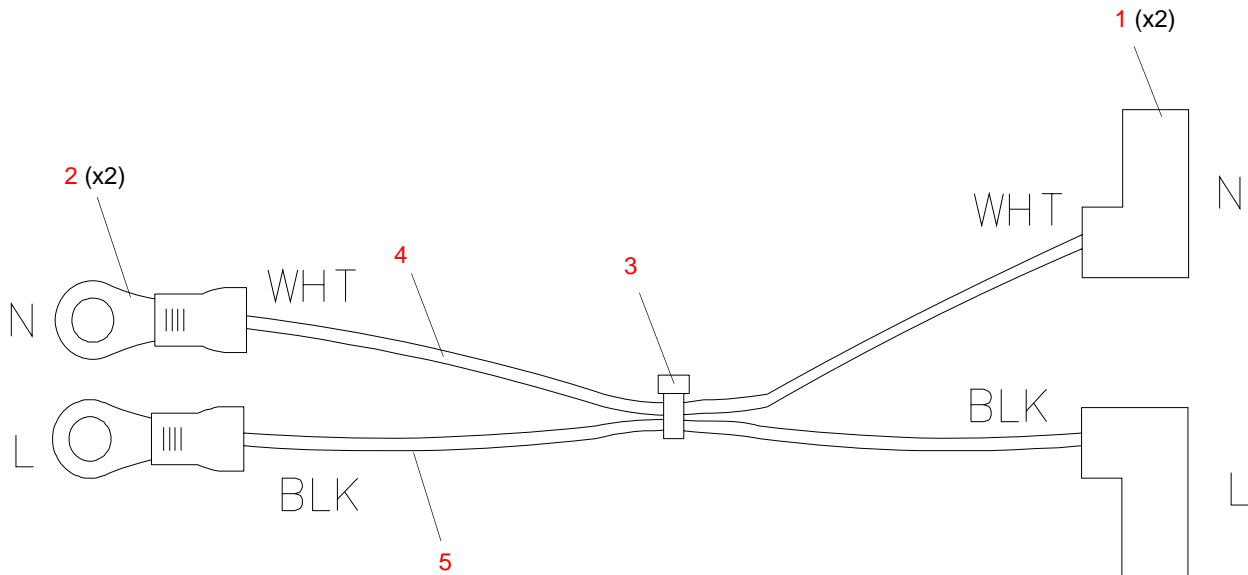

Figure 3-60: Dimmer to LVS Cable Assembly

Dimmer to Controller Cable Assembly

25.9663.2026 Rev 0

Refer to [Figure 3-61](#).

No.	Item	Qty.	UM.	Description
1	52.6396.2403	2	EA	RECEPT, 3POS MTA100 W/POL TAB 24AWG
2	73.5119.0246	3.50	FT	WIRE, 24AWG 3COND TW (RED-YEL-BLU) UL1213

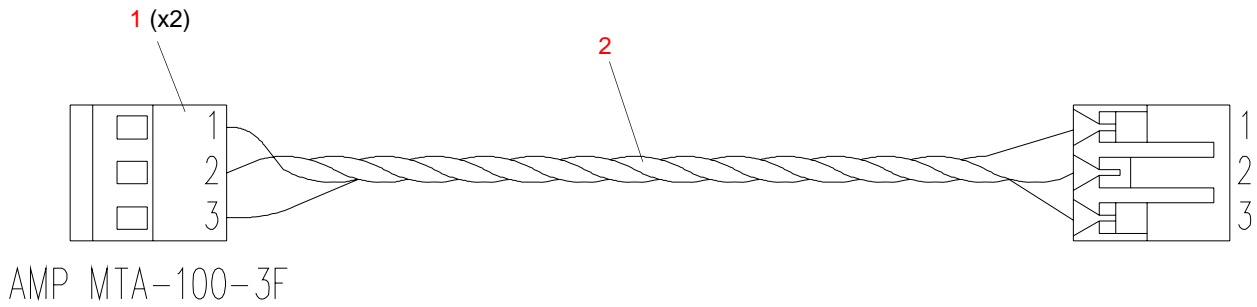

Figure 3-61: Dimmer to LVS Cable Assembly

Dimmer to Lamp Socket Cable Assembly

25.9663.2037 Rev 0

Refer to [Figure 3-62](#).

No.	Item	Qty.	UM.	Description
1	25.9663.2018	1	EA	CABLE ASSY, HEAD TO BACKCAP GND
2	52.8313.0001	2	EA	RECEPT, FASTON 1/4" 18-14AWG FLAG DBLCRP
3	52.8386.0001	2	EA	CONN., BUTT SPLICE 16-22AWG UNINSULATED
4	55.2186.0002	1	EA	CABLE TIE, .09" WD, 3.750" LG TEFZEL
5	55.2200.0003	0.33	FT	HEATSHRINK, 3/16" VITON
6	55.2260.0133	4.0	FT	SLEEVING, FIBERGLASS, 0.133" ID
7	55.2260.0294	1.75	FT	SLEEVING, FIBERGLASS, 0.294" ID
8	73.6616.0011	3.50	FT	WIRE, 16 AWG 600V 600C MICA TAPE TAN
9	73.7089.0001	6.67	FT	WIRE, 22 AWG BRN TEFLON STRANDED
10	73.7089.0006	6.67	FT <td WIRE, 22 AWG BLU TEFLON STRANDED	

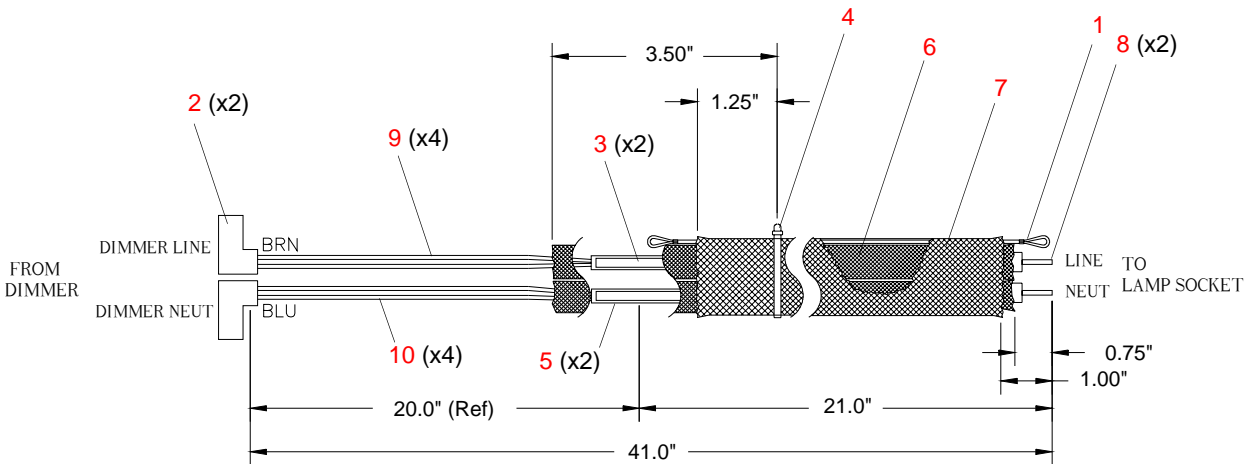

Figure 3-62: Dimmer to LVS Cable Assembly

575W Ballast I/O Cable Assembly

25.9663.1907 Rev C

Refer to [Figure 3-63](#).

No.	Item	Qty.	UM.	Description
1	52.6231.0001	1	EA	PLUG HOUSING, MNLOK PLUG 3POS
2	52.6396.2204	1	EA	RECEPT, 4POS MTA100 W/POL TAB RED CLSD END
3	52.6400.0111	1	EA	RECEPT, 17-9 STD SEX CPC 600V KEY A SQ FLANGE
4	52.8201.0005	3	EA	PIN, GOLD 24-20AWG TYPE3+ REEL .040-.080 INS DIA
5	52.8202.0001	5	EA	PIN, GOLD 18-16AWG TYPE 3+ REEL .080-.100 INS DIA
6	52.8202.0011	1	EA	PIN, GND GOLD 18-16AWG TYPE 3+ REEL .080-.100 INS DIA
7	52.8231.0005	3	EA	TERM, RING #6 BLUE 16-14 AWG REEL PIDG
8	52.8257.0002	2	EA	PIN, PHOS BRZ 20-14AWG (REEL) MNLOK .060"- .130"INS DIA
9	52.8313.0001	2	EA	RCPT, FASTON 1/4" 18-14 AWG FLAG DBL CRP (REEL)
10	52.8314.0001	1	EA	PIN, GND 20-14AWG (REEL) MNLOK .060"- .130"INS DIA
11	55.2186.0001	5	EA	CABLE TIE, .10"WD 4.00"LG SMALL
12	55.2199.1500	.19	FT	HEATSHRINK, 1 1/2" BLACK
13	67.4018.0001	1	EA	FERRITE, 26 X 28.5 X 13MM, CYLINDRICAL CORE
14	73.3522.0002	0.25	FT	WIRE, 22AWG 300V 105C PVC RED UL1569
15	73.3522.0009	0.25	FT	WIRE, 22AWG 300V 105C PVC WHT UL1569
16	73.3522.0010	0.25	FT	WIRE, 22AWG 300V 105C PVC BLK UL1569
17	73.6016.0003	2.19	FT	WIRE, 16AWG 600V 105C PVC ORG UL1015
18	73.6016.0007	2.02	FT	WIRE, 16AWG 600V 105C PVC VIO UL1015
19	73.6016.0009	0.50	FT	WIRE, 16AWG 600V 105C PVC WHT UL1015
20	73.6016.0010	0.50	FT	WIRE, 16AWG 600V 105C PVC BLK UL1015
21	73.6016.0504	1.33	FT	WIRE, 16AWG 600V 105C PVC GRN/YEL UL1015

575W Ballast I/O Cable Assembly (continued)

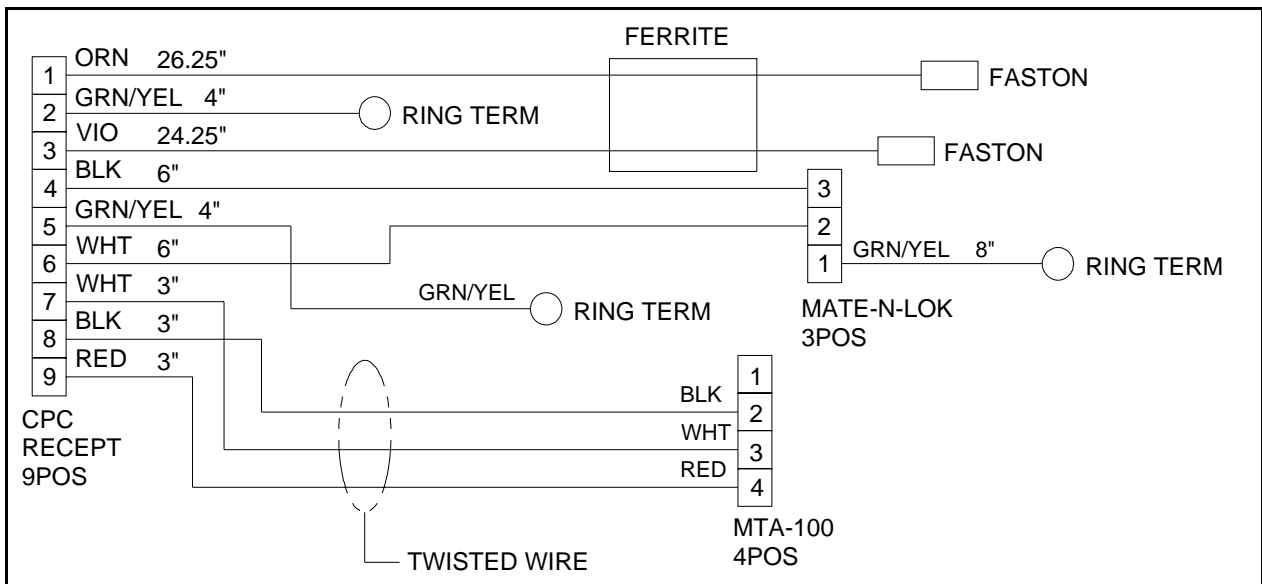
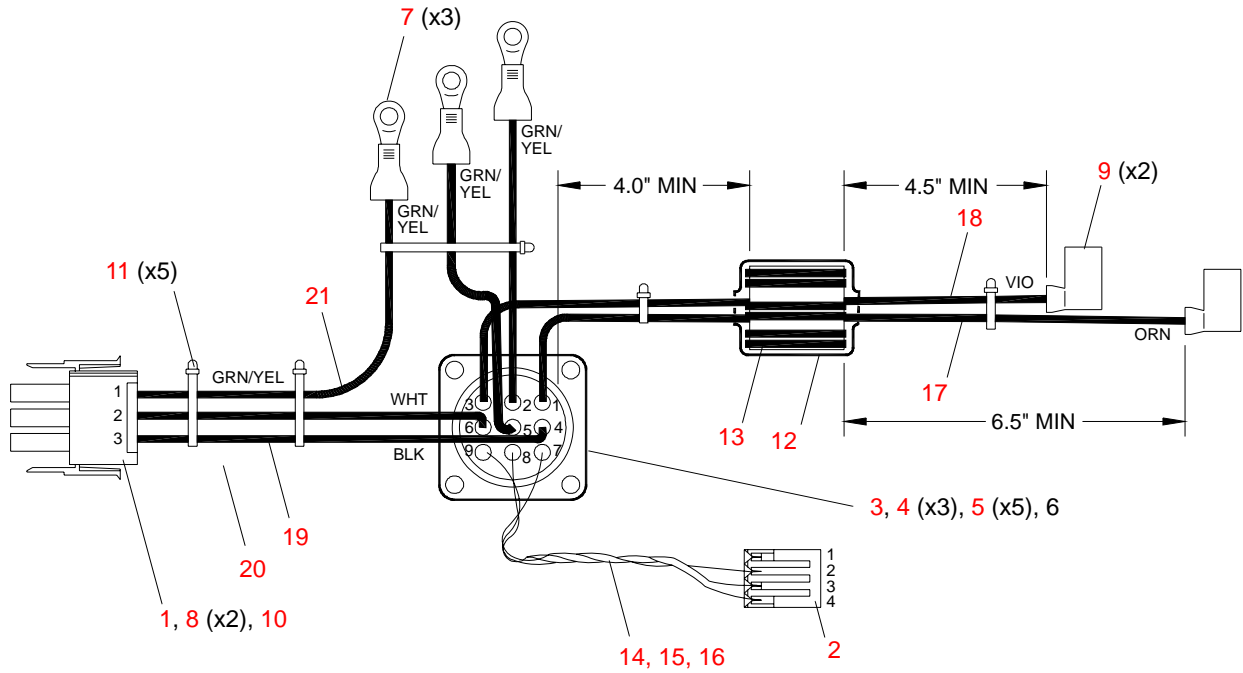

Figure 3-63: 575W Ballast I/O Cable Assembly

Notes

APPENDIX A.

Technical Bulletins

VL1000™ ERS Luminaire Technical Bulletins

The following table identifies the current technical bulletins associated with the VL1000™ ERS luminaire. These improvements have been incorporated into this manual.

Technical Bulletin	Description
S1K-001	VL1000 Tilt Bearing Hardware Check/Modification
S1K-002	VL1000 Lamp Wire Sleeving Modification
S1K-003A	VL1000 Arc Luminaire IR Coated Glass Retrofit
S1K-004A	VL1000 Incandescent Luminaire IR Coated Glass Retrofit
S1K-005	VL1000 Shutter Upgrade
S1K-006	VL1000 LVS Upgrade
S1K-007	VL1000 Thermostat Jumper Wire Assembly Installation
S1K-008	VL1000 LVS Kit Installation Procedure
S1K-009	VL1000 IGBT Dimmer Module Modification Procedure
TN-229A	Powering VARI* LITE ® Luminaires From Dimmer Circuits - NOT RECOMMENDED
TN-230	Dousing Lamps Before Shutting Off Power
TN-232	Use of Third Party Accessories

Technical Bulletins, Software Updates, support, and other information is available online at www.vari-lite.com under the "Support" link. To request access to the password-protected support areas, please contact Vari-Lite Customer Service at 1-877-827-4548 or +1-214-647-7880 or customerservice@genlytecontrols.com.

Notes



VARI*LITE®
Express yourself.

Vari-Lite
10911 Petal Street
Dallas, Texas 75238 USA
1.877.VARI-LITE * Fax 1.214.647.8038
www.vari-lite.com

Date: **14-May-2009** / Manual Part Number: **02.9663.0010 F**