



ARCHITECTURAL LIGHTING DIVISION

V.I.P. DIA

HTI / HMD 300

Congratulations on choosing a Clay Paky product! We thank you for your custom. Please note that this product, as all the others in the rich Clay Paky range, has been designed and made with total quality to ensure excellent performance and best meet your expectations and requirements.

INSTRUCTIONS MANUAL

Carefully read this instructions manual in its entirety and keep it safe for future reference.

It is essential to know the information and comply with the instructions given in this manual in order to ensure the fitting is installed, used and serviced correctly and safely.

CLAY PAKY S.p.A. disclaims all liability for damage to the fitting or to other property or persons deriving from installation, use and maintenance that have not been carried out in conformity with this instructions manual, which must always accompany the fitting.

CLAY PAKY S.p.A. reserves the right to modify the characteristics stated in this instructions manual at any time and without prior notice.

1 SAFETY INFORMATION

• Installation

Make sure all the parts for fixing the projector are in a good state of repair. Make sure the point of anchorage is stable before positioning the projector.

• Minimum distance from illuminated objects

The projector needs to be positioned so that the objects hit by the beam of light are at least 1 metre (3'3") from the lens of the projector.

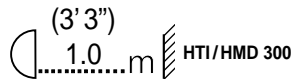

• Minimum distance from flammable materials

The projector must be positioned so that any flammable materials are at least 0.10 metres (4") from every point on the surface of the fitting.



It is permissible to mount the fitting on normally flammable surfaces.

• Maximum ambient temperature

For the fitting to operate well and reliably, the ambient temperature should not exceed 35°C (95°F).

• IP20 protection rating

The fitting is protected against penetration by solid bodies with a diameter of over 12 mm (0.47") (first digit 2), but not against dripping water, rain, splashes or jets of water (second digit 0).

• Protection against electrical shock

This fitting is classified, in accordance with the type of protection against electrical shock, in **Class I**. It must therefore be connected to a power supply system with efficient earthing.

It is, moreover, recommended to protect the supply lines of the projectors from indirect contact and/or shorting to earth by using appropriately sized residual current devices.

• Hooking up to the supply mains

The operations for connecting to the electricity mains must be carried out by a qualified electrical installer.

Check that the mains frequency and voltage correspond to the frequency and voltage for which the projector is designed, given on the electrical data label.

This label also gives the input power. Refer to this to evaluate the maximum number of fittings to connect to the electricity line in order to avoid overloading.

• Maintenance

Before starting any maintenance work or cleaning the projector, cut off power from the supply mains.

After switching off, do not remove any parts of the fitting for 4 minutes. After this time the likelihood of the lamp exploding is virtually nill. If it is necessary to replace the lamp, wait for another 15 minutes to avoid getting burnt.

The fitting is designed to hold in any splinters produced by a lamp exploding. The lenses must be mounted and, if visibly damaged, they have to be replaced with genuine spares.

• Temperature of the external surface

The maximum temperature that can be reached on the external surface of the fitting, in a thermally steady state, is 100°C (212°F).

• Lamp



The fitting mounts a high-pressure lamp that needs an external igniter. This igniter is fitted onto the fitting.

- Carefully read the "operating instructions" provided by the lamp manufacturer.
- Immediately replace the lamp if damaged or deformed by heat.



The products referred to in this manual conform to the European Community Directives to which they are subject:

- Low Voltage 73/23
- Electromagnetic Compatibility 89/336

2 UNPACKING AND PREPARATION

• Unpacking

Open the cardboard box, take out the polystyrene wrapping and separate it, freeing the projector. Remove the plastic bag from the projector and position this on a horizontal top.

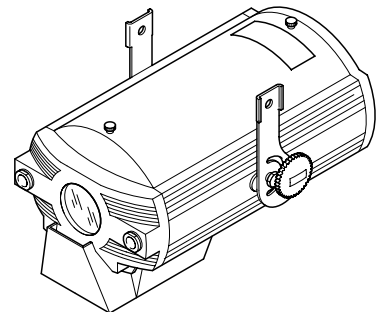

• Packing contents

Besides the projector, the packing also contains the following accessories:

- Bracket code 173008/001 (1).
- 2 countersunk head screws M6x10 mm code 020005/021 (2).
- 2 countersunk washers code 020214/001 (3).
- Hexagonal wrench 4 mm code 050004 (4).
- 2 accessory holder guides of standard length 170 mm code 173007/801 (5).
- Double ended wrench 7/8 mm code 050003 (6).
- Wrench 16 mm cod. 750467/001 (7).
- Standard lens 1:2.4/100mm code 173040/801 (8).
- Lens mounting code 173051/801 (9).
- Lens hood plate code 173017/001 (10).
- Socket for mounting on cable code 030210 (11).
- This instructions manual code 099575 (12).

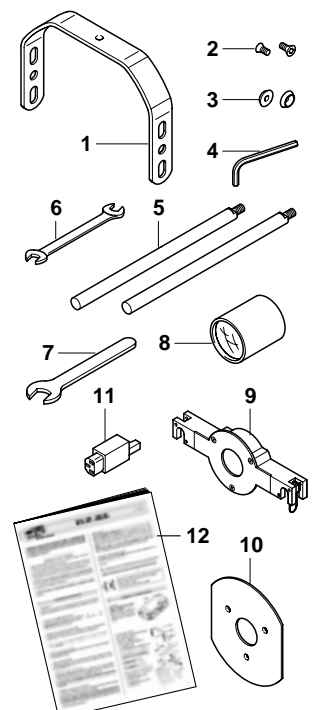

• Fitting projector mounting

Position the bracket (1) on the plates (13) according to the desired height. In correspondence with the chosen hole, place the countersunk washers (3) and the screws (2), then lock it all with the aid of the Allen wrench supplied (4). Adjust the projector mounting in the desired position and lock it with the knobs (14).

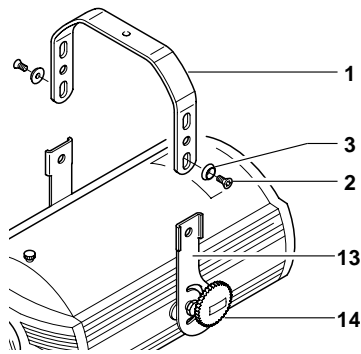

The bracket (1) can also be fitted towards the bottom of the projector. To do this, it is necessary, before fitting the bracket, to extract the knobs (14) from the rear hole and turn through 180° both the plates (13) and the spacers (15), then put the knobs (14) back into the front hole.

IMPORTANT: The central screw (16) must never be removed so as not to jeopardize the balance of the projector on the mounting.

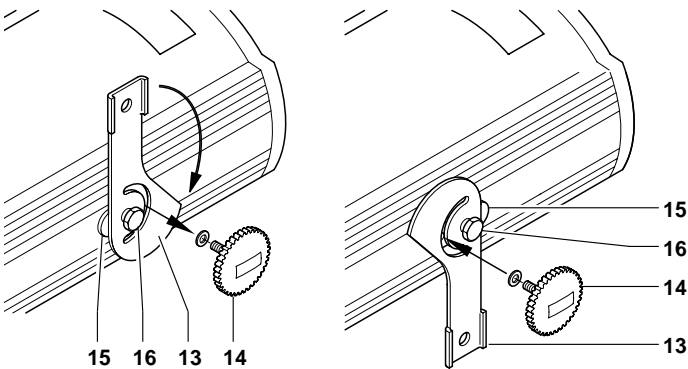

• Fitting the accessory holder guides

Screw the two accessory holder guides (5) into the threaded hole of the inserts (17), and tighten them appropriately with the 8 mm double ended wrench (6) supplied.

IMPORTANT: during this operation, take care not to turn the inserts (17) by blocking them in their position with the 16 mm special wrench (7) also supplied.

The accessory holder guides (5) are electrified at an extra-low safety voltage (24V ac) and protected against short-circuiting. This permits installing the entire range of motor driven and timed accessories available.

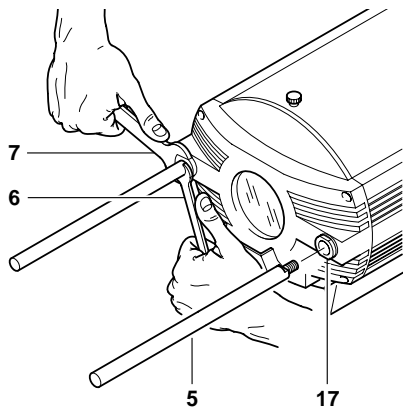

• Inserting the lamp

Refer to the instructions for opening the projector and changing the lamp in paragraph 4 MAINTENANCE.

3

INSTALLATION

• Installing the projector

The fitting must only be secured with the specific mounting, through the hole in the bracket (1). It is recommended to use a screw $\varnothing 10$ with nut and spring washer.

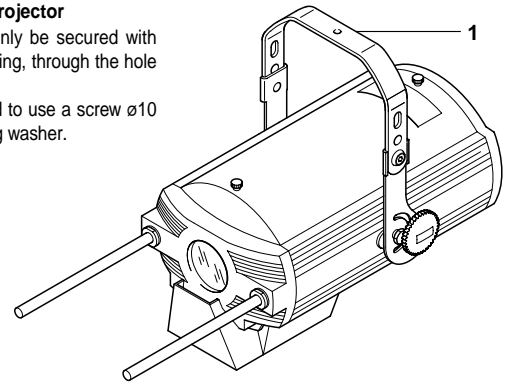

• Mains power connection

The projector has to be hooked up to the electricity mains via the specific socket (11) supplied.

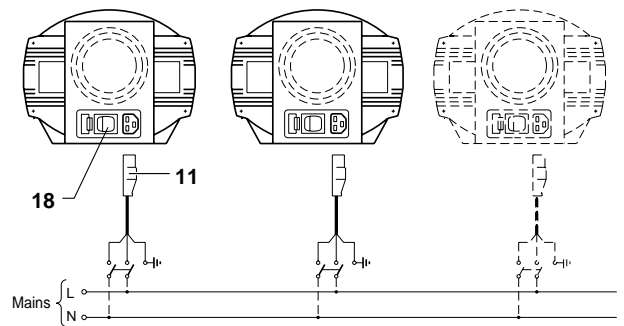

• Switching on the projector

After carrying out all the above operations, press the switch (18) checking that the projector works properly.

• Fitting the lens hood on the lens holder

If you wish to fit the lens hood plate (10) on the lens mounting (9), take out the 3 screws (19) with the aid of a Phillips screwdriver. Position the lens hood plate (10) on the cover ring (20) of the lens mounting (9) and put back in the 3 screws (19) tightening them appropriately.

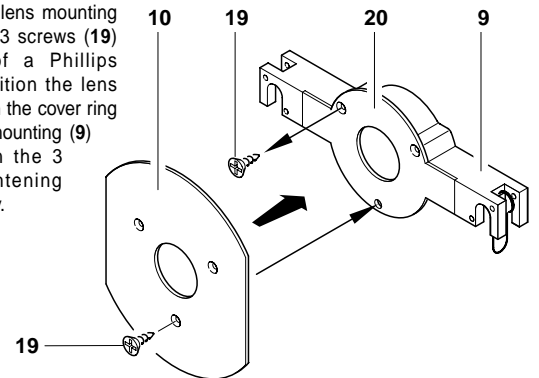

• Fitting the lens

Insert the lens (8) into the mounting (9) and tighten the handwheel (21). Rest the lens mounting on the guides (5) and lock it by turning the fixing clips (22) inwards until they clip on.

In addition to the lens supplied as standard there is a vast range of optional lenses.

• Fitting accessories for special effects

Fit the desired accessories on the guides, referring to the assembly instructions provided with the accessories.

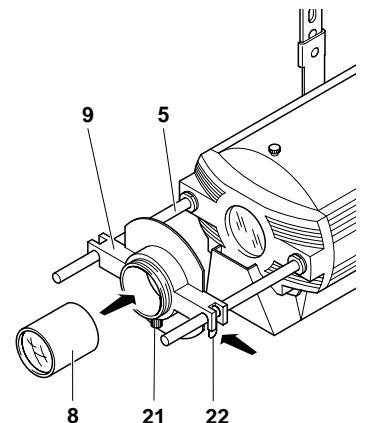

• **Centring the projector**

Slightly undo the mounting screw (23), move the projector horizontally, turning the beam of light in the desired direction, then re-tighten the mounting screw. Loosen the knobs (14), move the projector vertically on the bracket (1) to position the beam of light at the desired point, then lock the knobs (14).

• **Centring the lens**

Move the lens (8) and/or lens holder (9) axially to obtain perfect focusing.

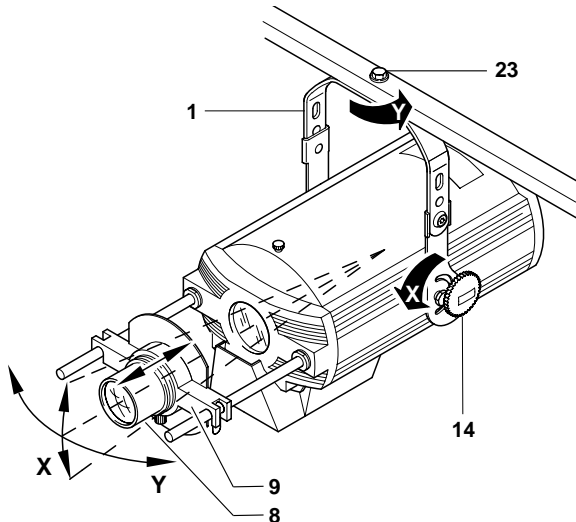

• **Rotating the axis of projection**

The holes on the bracket (1) for fixing the plates (13) are appropriately slotted to permit rotating the fitting on its axis by approximately 3°. This permits fine adjustment of the angle of the image projected, which is useful when using some particular accessories such as for slide or gobo projection.

Using the hexagonal wrench (4) supplied, loosen a screw (2) and turn the projector to the position required, and then re-tighten the screw (2).

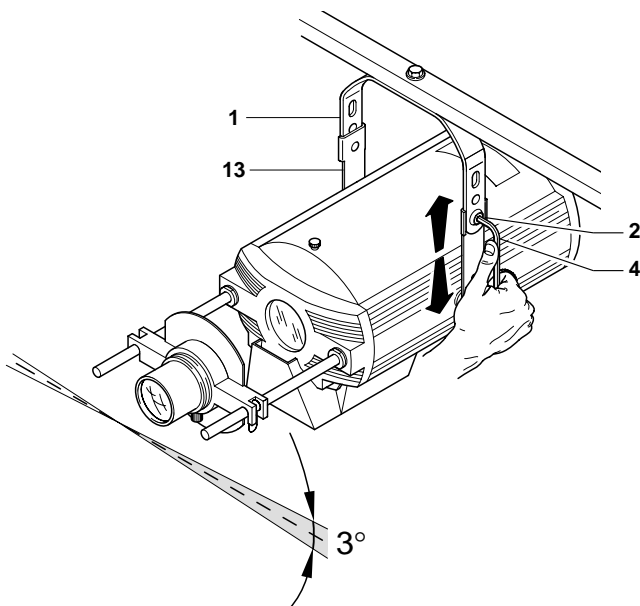

4

MAINTENANCE

• **Opening and closing the projector**

Loosen the handwheels (24) and remove the re-lamping cover (25) from the projector. After maintenance, fit the cover (25) back on and lock the handwheels (24).

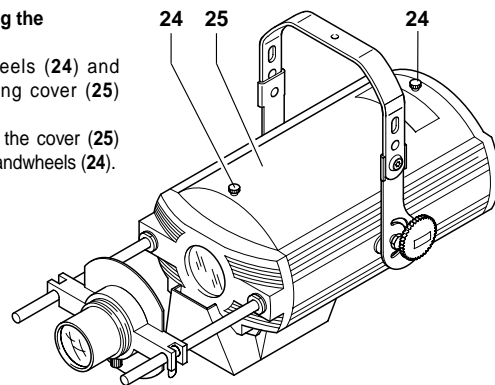

• **Re-lamping**

After opening the projector, loosen the two side ring nuts (26) of the lamp to replace and remove it from the mountings (27).

Take the new lamp out of its package, loosen the two side ring nuts (26) and insert it in the mountings (27), then screw the fixing ring nuts back on.

WARNING: Do not touch the lamp's bulb with bare hands. Should this happen, clean the bulb with a cloth soaked in alcohol and dry it with a clean, dry cloth.

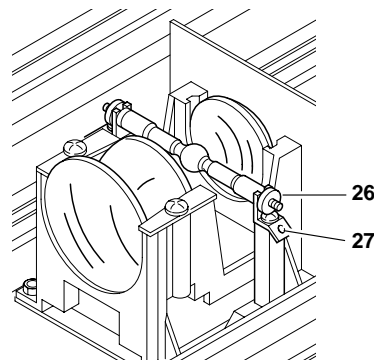

IMPORTANT: To distribute the beam of light uniformly, the lamp needs to be positioned with the protrusion (28) visible on the bulb outside the optical axis of the projector. For this purpose it is recommended to turn the protrusion towards towards the top cover (25) of the projector.

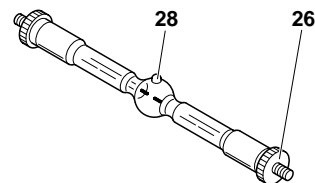

• **Replacing fuses**

To replace the fuses press the tab (29) and take out the fuse-holder box (30). Replace the broken fuses with new ones of the type described on the label (31) on the fuse-holder box (30). Put it back in so the tab clicks home (29).

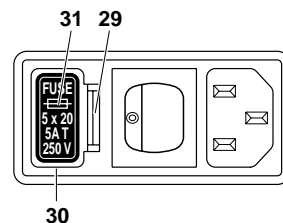

• **Periodical cleaning**

To keep the luminous efficiency of the projector unchanged, it is vital to periodically clean the parts where dust and grease can accumulate.

Observing the following guidelines will help keep the projector in perfect working order for a long time.

To remove dirt from the lens, use a soft cloth dampened with any liquid detergent for cleaning glass.

Caution: Never use solvents or spirits.

○ Parts requiring frequent cleaning.

● Parts requiring monthly cleaning.

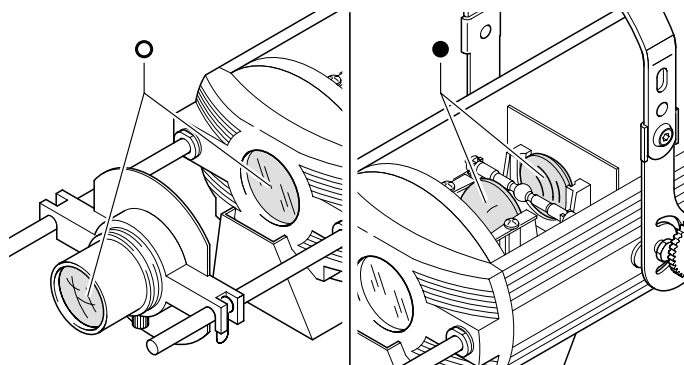

THE PROJECTOR WILL NOT SWITCH ON				TROUBLE
NO MOTOR-DRIVEN ACCESSORY WORKS				
DEFECTIVE PROJECTION				
REDUCED BRIGHTNESS				
		POSSIBLE CAUSES	CHECKS AND REMEDIES	
●		No mains supply.	Check the supply socket is powered and/or fuse conductivity.	
●	●	Lamp exhausted or defective.	Replace the lamp. (See instructions).	
●		No power on the guides.	Call an authorized technician.	
●		The accessory motors fail to work.	Call an authorized technician.	
	●	Lenses or reflector broken.	Call an authorized technician.	
	● ●	Dust or grease deposited.	Clean. (See instructions).	

Power supplies available

- Version with built-in power factor correction:
 - 220 - 240V 50Hz
 - 200V 50Hz - 230V 60Hz
 - 200 - 220V 60Hz
 - 260V 50Hz
- Version without built-in power factor correction:
 - 220 - 240V 50Hz
 - 200V 50Hz - 230V 60Hz
 - 200 - 220V 60Hz
 - 260V 50Hz
 - 120V 60Hz
 - 100V 50Hz
 - 100V 60Hz

The projector is designed to operate at the mains frequency and voltage given on the electrical data label on the back of the appliance.

Input power

- Versions with built-in power factor correction: 450VA at 230V 50Hz (standard power factor correction 35µF).
- Versions without built-in power factor correction: 800VA at 230V 50Hz.

Lamp

Metal halide supplied with special built-in power supply unit.

- Type HTI 300W
 - Connection SFc 10-4
 - Colour temperature 6,500 K
 - Luminous flux 22,000 lm
 - Average life 750 h
 - Any working position
- Type HMD 300W
 - Connection SFc 10-4
 - Colour temperature 5,700 K
 - Luminous flux 20,000 lm
 - Average life 3,000 h
 - Working position p45

Optical unit

- Base in die-cast aluminium.
- Twin lens condenser.
- Spherical reflector with a high luminous efficiency.

Lens units

- Standard: 1:2,4/100 mm (30,9°)
- Optional: 1:2,8/45 mm multi-lens (64,2°)
- Optional: 1:2,8/60 mm multi-lens (45,8°)
- Optional: 1:2,8/85 mm multi-lens (34,4°)
- Optional: 1:2,8/120 mm multi-lens (24,1°)
- Optional: 1:3,5/150 mm multi-lens (19,5°)
- Optional: 1:4/165 mm (17,2°)
- Optional: 1:4,4/200 mm (14,3°)
- Optional: 1:3,5/70÷120 mm zoom (39,5°÷22,9°)

Safety Devices

- Power supply automatically cut off in the event of overheating.
- Power supply cut off on opening the cover.
- Short-circuiting protection on the accessory holder guides.

Cooling

By forced ventilation with the axial fan (projector body) and radial fan (slide holder accessory).

Body

- In die-cast and extruded aluminium.
- Epoxy powder painting.

Mounting

- Bracket in steel painted with epoxy powders.
- Three installation positions with a step of 25 mm (0.98").
- Bracket adjustable on 120°.

Working position

Operation in any position, limited to the specifications of the lamp used.

Weights and dimensions

- Versions 200-240V with PFC: 7,8 kg (17 lbs 3 ozs).
- Versions 200-240V without PFC: 7,3 kg (16 lbs 1 ozs).
- Versions 100-120V without PFC: 10,2 kg (22 lbs 7 ozs).

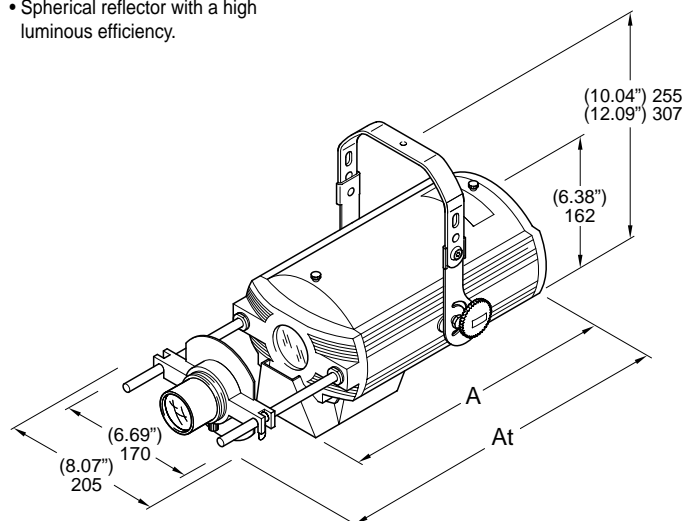

	200-240V with PFC	200-240V without PFC	100-120V without PFC
A	14.84" 377 mm	12.60" 320 mm	14.84" 377 mm
At	21.22" 539 mm	18.98" 482 mm	21.22" 539 mm