

CHANNEL	EFFECT
1	IRIS
2	COLOUR EFFECTS
3	FROST
4	DIMMER / STOPPER / STROBE
5	PAN
6	TILT
7	ZOOM
8	FOCUS
9	ROTATING PRISM CHANGE
10	PRISM ROTATION
11	FIXED GOBO CHANGE
12	ROTATING GOBO CHANGE
13	GOBO ROTATION
14	RED (option 8 OFF) CYAN (option 8 ON)
15	GREEN (option 8 OFF) MAGENTA (option 8 ON)
16	BLUE (option 8 OFF) YELLOW (option 8 ON)
17	LAMP CONTROL (only with option 3 ON)
18	PAN FINE (only with option 4 ON)
19	TILT FINE (only with option 4 ON)
20	GOBO FINE (only with option 7 ON)

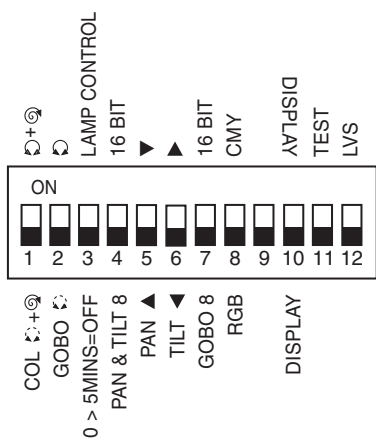

I La scelta delle opzioni si effettua commutando i microinterruttori secondo le indicazioni sotto riportate.

GB Select the options by setting the microswitches as indicated.

F Pour choisir les options, commutez les microswitch en fonction des indications ci-dessous.

D Die Wahl der Optionen erfolgt durch Umschaltung der Mikroschalter gemäß den unten gelieferten Angaben.

E Para definir las opciones, disponer los microconmutadores como se indica a continuación.

OPTION	FUNCTION
1	ON Movimento lineare del disco colori <i>Linear movement of the colour wheel</i> Mouvement linéaire du disque de couleurs <i>Stufenlose Bewegung des Farbrads</i> Movimiento lineal del disco de colores
	OFF Movimento a passi fissi del disco colori <i>Stepped movement of the colour wheel</i> Mouvement à pas fixes du disque de couleurs <i>Schrittweise Bewegung des Farbrads</i> Movimiento a pasos fijos del disco de colores
2	ON Movimento lineare del disco gobo fissi <i>Linear movement of the fixed gobo disc</i> Mouvement linéaire du disque gobo fixes <i>Stufenlose Bewegung des Rads mit nicht drehbaren Gobos</i> Movimiento lineal del disco de gobos fijos
	OFF Movimento a passi fissi del disco gobo fissi <i>Stepped movement of the fixed gobo disc</i> Mouvement à pas fixes du disque gobo fixes <i>Schrittweise Bewegung des Rads mit nicht drehbaren Gobos</i> Movimiento a pasos fijos del disco de gobos fijos
3	ON Controllo lampada (canale 17) abilitato <i>Lamp control (channel 17) enabled</i> Contrôle de la lampe (canal 17) validé <i>Lampenkontrolle (Kanale 17) aktiviert</i> Control de la lámpara (canal 17) habilitado
	OFF Spegnimento lampada dopo 5 min. di blackout (canale 17 disabilitato) <i>Auto light off after 5 min. of blackout (channel 17 disabled)</i> Arrêt de la lampe après 5 min d'interruption de l'alimentation (canal 17 invalide) <i>Ausschalten der Lampe nach 5 Min. Blackout (Kanal 17 deaktiviert)</i> Apagado de la lámpara a los 5 min del corte de señales (canal 17 inhabilitado)
4	ON Abilitazione regolazione PAN Fine e TILT Fine (canali 18-19) <i>PAN Fine and TILT Fine control enable (channels 18-19)</i> Activation réglage PAN Fin et TILT Fin (canaux 18-19) <i>Einschaltung Feineinstellung PAN / TILT (Kanäle 18-19)</i> Habilitar regulación GIRO Fino y INCLINACIÓN Fina (canales 18-19)
	OFF Disabilitazione regolazione PAN Fine e TILT Fine <i>PAN Fine and TILT Fine control disable</i> Désactivation réglage PAN Fin et TILT Fin <i>Ausschaltung Feineinstellung PAN / TILT</i> Inhabilitar regulación GIRO Fino y INCLINACIÓN Fina
5	- Inversione movimento orizzontale (PAN) <i>PAN direction change</i> Inversion mouvement horizontal (PAN) <i>Umkehr Horizontalbewegung (PAN)</i> Invertir movimiento horizontal (GIRO)
6	- Inversione movimento verticale (TILT) <i>TILT direction change</i> Inversion mouvement vertical (TILT) <i>Umkehr Vertikalbewegung (TILT)</i> Invertir movimiento vertical (INCLINACIÓN)
7	ON Abilitazione regolazione GOBO Fine (canale 20) <i>GOBO Fine control enable (channel 20)</i> Activation réglage GOBO Fin (canal 20) <i>Einschaltung Feineinstellung GOBO (Kanäl 20)</i> Habilitar regulación GOBO Fino (canal 20)
	OFF Disabilitazione regolazione GOBO Fine <i>GOBO Fine control disable</i> Désactivation réglage GOBO Fin <i>Ausschaltung Feineinstellung GOBO</i> Inhabilitar regulación GOBO Fino
8	ON Selezione sistema di miscelazione colori CMY <i>CMY colour mixing system selected</i> Sélection système de mélange couleurs CMY <i>Farbenmischsystem CYM wählen</i> Selección sistema de mezclado de los colores CMY
	OFF Selezione sistema di miscelazione colori RGB <i>RGB colour mixing system selected</i> Sélection système de mélange couleurs RGB <i>Farbenmischsystem RGB wählen</i> Selección sistema de mezclado de los colores RGB
9	- Non usata <i>Not used</i> Non utilisé <i>Nicht belegt</i> No utilizada
10	ON Orientamento display per installazione a soffitto <i>Display orientation for ceiling installation</i> Orientation de l'afficheur pour l'installation au plafond <i>Orientierung des Displays für die Deckeninstallation</i> Orientación del display para instalación en el techo
	OFF Orientamento display per installazione a pavimento <i>Display orientation for floor installation</i> Orientation de l'afficheur pour l'installation au sol <i>Orientierung des Displays für die Bodeninstallation</i> Orientación del display para instalación en el suelo
11	- Test
12	- Se ON, sul pin no. 5 del connettore di ingresso del segnale DMX è presente una bassa tensione in uscita (il LED blu è acceso per mostrare questa condizione). <i>If ON, there is Low Voltage Supply on output at DMX signal input connector pin n° 5 (the blue LED is ON to show this condition).</i> Si ON, il y a une basse tension en sortie sur la broche n.5 du connecteur d'entrée du signal DMX (la LED bleue est allumée pour indiquer cette condition). <i>Wenn ON, ist auf dem Pin Nr. 5 des Steckers für das Eingangssignal DMX eine Niedervolt Versorgungsspannung vorhanden (die blaue LED leuchtet, um diesen Zustand anzuzeigen).</i> Si está en ON, en el pin no. 5 del conector de entrada de la señal DMX, se produce una baja tensión de salida (el LED azul está encendido para indicar esta condición).

• IRIS - channel 1

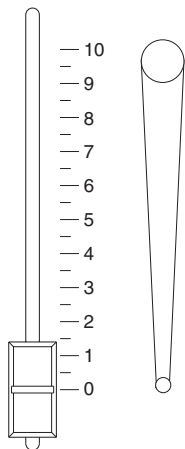

BIT	%	EFFECT
255	100	MAXIMUM APERTURE
0	0.0	MINIMUM APERTURE

• COLOUR EFFECTS - channel 2

Operation with option 1 OFF

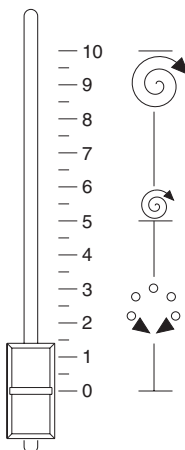

BIT	%	EFFECT
255	100	FAST ROTATION (300 rpm)
128	50.0	SLOW ROTATION (10 rph)
120 - 127	47.0 - 49.7	U.V. FILTER + WHITE
112 - 119	44.0 - 46.7	U.V. FILTER
104 - 111	41.0 - 43.7	4 COLOUR FILTER + U.V. FILTER
96 - 103	37.5 - 40.5	4 COLOUR FILTER
88 - 95	34.2 - 37.0	RED + 4 COLOUR FILTER
80 - 87	31.2 - 34.0	RED
72 - 79	28.2 - 31.0	YELLOW WITH HOLE + RED
64 - 71	25.0 - 28.0	YELLOW WITH HOLE
56 - 63	22.0 - 24.7	BLUE WITH HOLE + YELLOW WITH HOLE
48 - 55	18.7 - 21.7	BLUE WITH HOLE
40 - 47	15.5 - 18.2	COLD FILTER + BLUE WITH HOLE
32 - 39	12.5 - 15.0	COLD FILTER
24 - 31	9.5 - 12.0	WARM FILTER + COLD FILTER
16 - 23	6.2 - 9.0	WARM FILTER
8 - 15	3.2 - 6.0	WHITE + WARM FILTER
0 - 7	0.0 - 3.0	WHITE

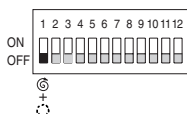

Operation with option 1 ON

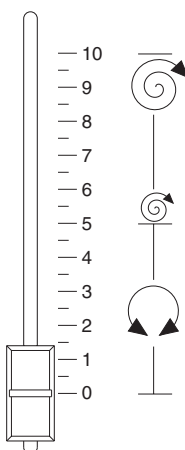

BIT	%	EFFECT
255	100	FAST ROTATION (300 rpm)
128	50.0	SLOW ROTATION (10 rph)
113	44.2	U.V. FILTER
97	38.0	4 COLOUR FILTER
81	31.7	RED
64	25.0	YELLOW WITH HOLE
48	18.7	BLUE WITH HOLE
32	12.5	COLD FILTER
16	6.2	WARM FILTER
0	0.0	WHITE

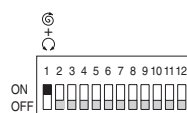

• FROST - channel 3

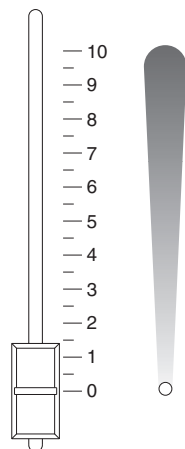

BIT	%	EFFECT
255	100	FROST INSERTED
0	0.0	FROST EXCLUDED

• DIMMER / STOPPER / STROBE - channel 4

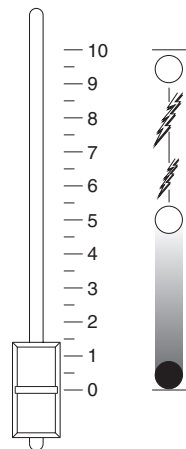

BIT	%	EFFECT
244 - 255	95.5 - 100	OPEN
243	95.0	FAST STROBE (11 flash/sec)
140	54.7	SLOW STROBE (1 flash/sec)
128 - 139	50.0 - 54.2	OPEN
0	0.0	CLOSED

Dopo 10 secondi in cui il canale è a livello 0, il proiettore commuta automaticamente alla modalità di funzionamento half power/half noise nella quale la luminosità della lampada viene dimmerata al 50% del valore nominale e la velocità di alcune ventole viene rallentata in modo da ridurre la rumorosità prodotta dalle ventole stesse. La modalità full power si ripristina immediatamente quando al canale si assegna un livello maggiore di zero.



Il funzionamento nella modalità half power/half noise è abilitato solo dopo che la lampada ha funzionato in full power per un tempo di almeno 10 minuti dopo l'accensione del proiettore o lo spegnimento della lampada tramite il canale dedicato.

After 10 seconds during which the channel is at level 0, the projector automatically switches to the half power/half noise operating mode, where the brightness of the lamp is dimmed by 50% of the rated value and the speed of some of the fans is lowered to reduce the noise produced by the fans themselves. Full power mode is restored immediately when a level greater than zero is assigned to the channel.



Operating in half power/half noise mode is only enabled after the lamp has been running at full power for at least 10 minutes after the projector was switched on or the lamp switched off via the dedicated channel.

10 secondes après que le canal est au niveau 0, le projecteur commute automatiquement sur la modalité de fonctionnement half power/half noise. Dans cette modalité, la luminosité de la lampe est graduée à 50% de la valeur nominale et la vitesse de certains ventilateurs est ralentie de façon à réduire le bruit qu'ils produisent. La modalité full power est immédiatement rétablie quand on assigne un niveau supérieur à zéro au canal.



Le fonctionnement en modalité half power/half noise n'est autorisé qu'après que la lampe a fonctionné au moins 10 minutes en full power ou que la lampe a été éteinte au moyen du canal spécifique.

Nachdem der Kanal 10 Sekunden lang auf Stand 0 war, schaltet der Projektor automatisch in die Betriebsart half power/half noise um, in der die Lichtstärke der Lampe auf 50% des Nennwertes gedämpft wird und die Geschwindigkeit einiger Lüfter so herabgesetzt wird, daß sich die Geräusentwicklung durch die Lüfter verringert. Die Betriebsart full power stellt sich unverzüglich wieder ein, sobald dem Kanal ein Stand über Null zugeordnet wird.



Die Funktionsweise in der Betriebsart half power/half noise wird nur dann aktiviert, wenn die Lampe mindestens 10 Minuten lang in full power in Betrieb war, nachdem der Projektor eingeschaltet worden ist oder nach dem Ausschalten der Lampe über den entsprechenden Kanal.

Al cabo de 10 segundos en que el canal está en el nivel 0, el proyector se conmuta automáticamente al modo de funcionamiento half power/half noise, en el que la luminosidad de la lámpara se reduce al 50% del valor nominal y se desacelera la velocidad de algunos ventiladores para reducir el ruido producido por los mismos. El modo full power se restablece inmediatamente al asignar al canal un nivel mayor que cero.



El funcionamiento en el modo half power/half noise está habilitado sólo después que la lámpara ha funcionado en full power por un tiempo mínimo de 10 minutos después del encendido del proyector o el apagado de la lámpara por medio del canal dedicado.

• PAN - channel 5

Operation with option 5 OFF

BIT	%
255	100
0	0.0

ON OFF

1 2 3 4 5 6 7 8 9 10 11 12

Operation with option 5 ON

BIT	%
255	100
0	0.0

ON OFF

1 2 3 4 5 6 7 8 9 10 11 12

• TILT - channel 6

Operation with option 6 OFF

BIT	%
255	100
0	0.0

ON OFF

1 2 3 4 5 6 7 8 9 10 11 12

Operation with option 6 ON

BIT	%
255	100
0	0.0

ON OFF

1 2 3 4 5 6 7 8 9 10 11 12

• ZOOM - channel 7

BIT	%	EFFECT
255	100	NARROW BEAM
0	0.0	WIDE BEAM

• FOCUS - channel 8

BIT	%	EFFECT
255	100	NEAR
0	0.0	DISTANT

• ROTATING PRISM CHANGE - channel 9

BIT	%	EFFECT
208 - 255	81.7 - 100	5 FACE PRISM (3D)
156 - 207	61.2 - 81.2	2 FACE PRISM
104 - 155	41.0 - 61	5 FACE PRISM
52 - 103	20.5 - 40.5	4 FACE PRISM
0 - 51	0.0 - 20.0	WHITE

• PRISM ROTATION - channel 10

BIT	%	EFFECT
255	100	FAST ROTATION (120 rpm)
193	75.5	SLOW ROTATION (2 rph)
191 - 192	74.7 - 75.0	STOP
190	74.2	SLOW ROTATION (2 rph)
128	50.0	FAST ROTATION (120 rpm)
127	49.7	POSITION 540°
105	41.7	POSITION 450°
84	33.0	POSITION 360°
63	24.7	POSITION 270°
42	16.2	POSITION 180°
21	8.2	POSITION 90°
0	0.0	POSITION 0°

• **FIXED GOBO CHANGE - channel 11**

Operation with option 2 OFF

BIT	%	EFFECT
204 - 255	80.0 - 100	GOBO 4
152 - 203	59.5 - 79.5	GOBO 3
100 - 151	39.0 - 59.0	GOBO 2
48 - 99	18.7 - 38.7	GOBO 1
0 - 47	0.0 - 18.2	WHITE

ON OFF 1 2 3 4 5 6 7 8 9 10 11 12

Operation with option 2 ON

BIT	%	EFFECT
255	100	GOBO 4
192	75.0	GOBO 3
128	50.0	GOBO 2
64	25.0	GOBO 1
0	0.0	WHITE

ON OFF 1 2 3 4 5 6 7 8 9 10 11 12

• **ROTATING GOBO CHANGE - channel 12**

BIT	%	EFFETTO
208 - 256	81.7 - 100	GOBO 4
156 - 207	61.2 - 81.2	GOBO 3
104 - 156	41.0 - 61.0	GOBO 2
52 - 103	20.5 - 40.5	GOBO 1
0 - 51	0.0 - 20.0	WHITE

• **GOBO ROTATION - channel 13**

BIT	%	EFFECT
255	100	FAST ROTATION (120 rpm)
193	75.0	SLOW ROTATION (2 rph)
191 - 192	74.7 - 75.0	STOP
190	74.2	SLOW ROTATION (2 rph)
128	50.0	FAST ROTATION (120 rpm)
127	49.7	POSITION 540°
105	41.7	POSITION 450°
84	33.0	POSITION 360°
63	24.7	POSITION 270°
42	16.2	POSITION 180°
21	8.2	POSITION 90°
0	0.0	POSITION 0°

• **COLOUR MIXING - channel 14 - 15 - 16**

RGB system enabled (option 8 OFF)

BIT	%	EFFECT
255	100	COLOUR EXCLUDED
0	0.0	COLOUR INSERTED

ON OFF 1 2 3 4 5 6 7 8 9 10 11 12

CMY system enabled (option 8 ON)

BIT	%	EFFECT
255	100	COLOUR INSERTED
0	0.0	COLOUR EXCLUDED

ON OFF 1 2 3 4 5 6 7 8 9 10 11 12

• **LAMP CONTROL (only with option 3 ON) - channel 17**

BIT	%	EFFECT
256	100	LAMP ON (full power)
128	50.0	LAMP ON (full power)
127	49.7	LAMP ON (half power)*
64	25.0	LAMP ON (half power)*
63	24.7	LAMP OFF
0	0.0	LAMP OFF

LAMP CONTROL ON OFF 1 2 3 4 5 6 7 8 9 10 11 12

I * Il funzionamento della modalità half power/half noise è abilitato solo dopo che la lampada ha funzionato in full power per un tempo di almeno 10 minuti dopo l'accensione del proiettore o lo spegnimento della lampada. Prima che siano trascorsi i suddetti 10 minuti, ai livelli dal 25.0% al 49.7% il proiettore funziona in full power.

GB * Operating in half power/half noise mode is only enabled after the lamp has been running at full power for at least 10 minutes after the projector was switched on or the lamp switched off. The projector operates at full power at levels from 25.0% to 49.7% before these 10 minutes have elapsed.

F * Le fonctionnement en modalit  half power/half noise n'est autoris  qu'apr s que la lampe a fonctionn  au moins 10 minutes en full power apr s que le projecteur a  t  allum  ou que la lampe a  t   teinte. Avant que le temps susmentionn  de 10 minutes soit  coul , aux niveaux de 25,0%   49,7%, le projecteur fonctionne en full power.

D * Die Funktionsweise in der Betriebsart half power/half noise wird nur dann aktiviert, wenn die Lampe mindestens 10 Minuten lang in full power Betrieb war, nachdem der Projektor eingeschaltet oder die Lampe ausgeschaltet worden ist. Bevor die obengenannten 10 Minuten abgelaufen sind, funktioniert der Projektor auf dem Stand zwischen 25.0% und 49.7% in full power.

E * El funcionamiento en el modo half power/half noise est  habilitado s lo despu s que la l mpara ha funcionado en full power por un tiempo m nimo de 10 minutos despu s del encendido del proyector o el apagado de la l mpara. Antes de que pasen los 10 minutos, en los niveles del 25.0% al 49.7% el proyector funciona en full power.

• FINE PAN (only with option 4 ON) - channel 18

Operation with option 5 OFF

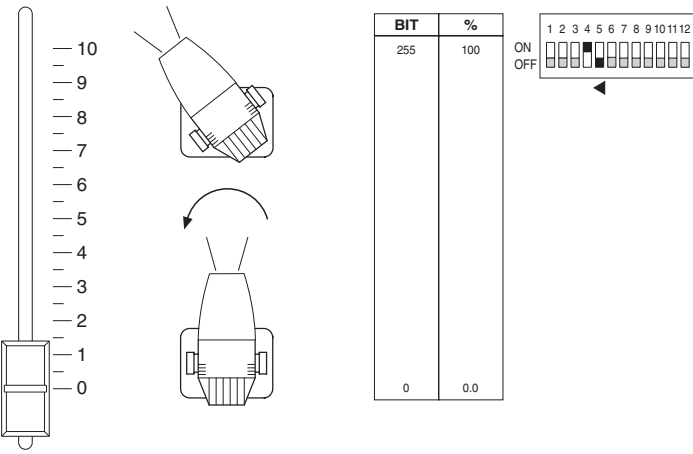

Operation with option 5 ON

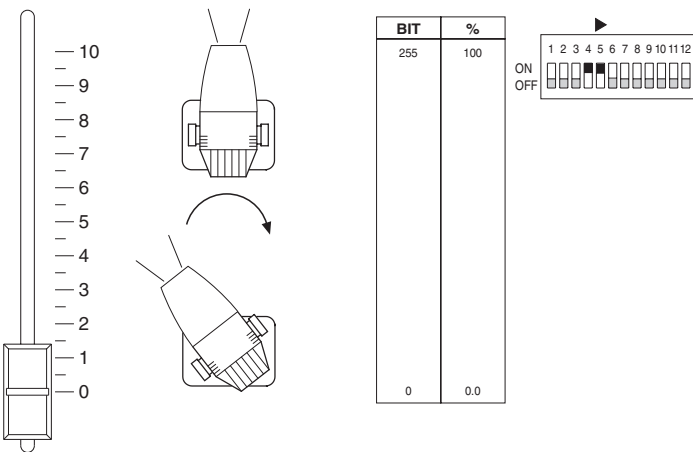

• FINE TILT (only with option 4 ON) - channel 19

Operation with option 6 OFF

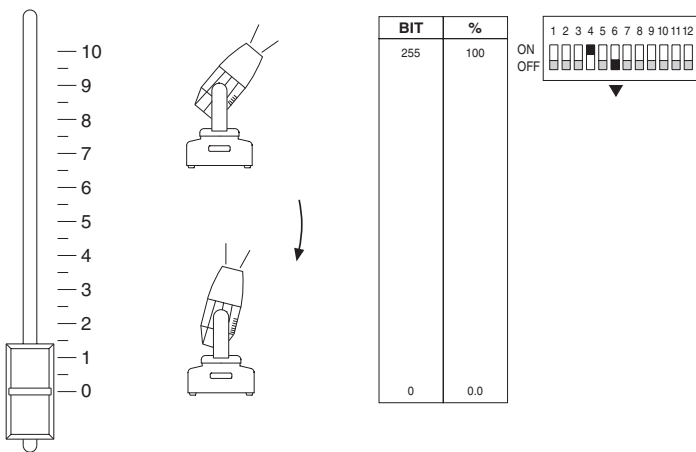

Operation with option 6 ON

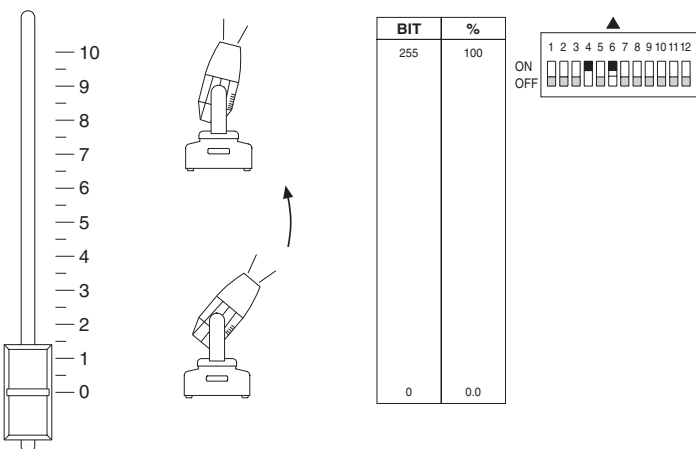

• GOBO FINE (only with option 7 ON) - channel 20

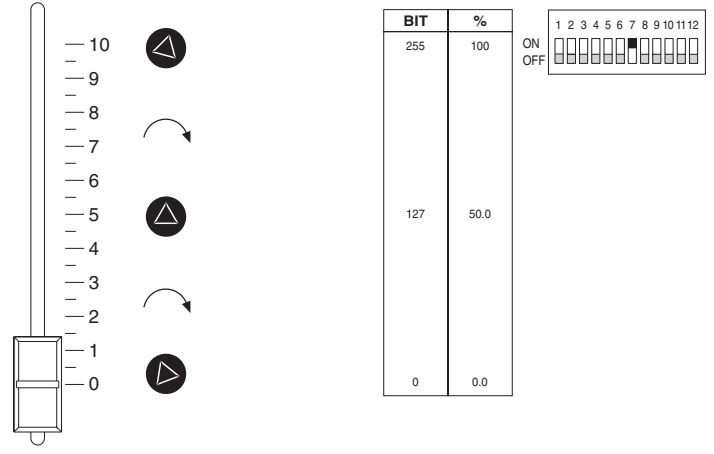

Mettendo tutti i canali a livello 0 (blackout), dopo un intervallo di circa 5 secondi, inizia una procedura di ricalibratura degli effetti (tutti eccetto il dimmer che rimane chiuso) grazie alla quale è possibile, dalla centralina di comando, riportare in posizione corretta eventuali effetti motorizzati che durante il funzionamento avessero accidentalmente "perso il passo".

L'intero ciclo di ricalibratura ha una durata di circa 40 secondi, e può essere interrotto in qualsiasi momento, semplicemente impostando un canale a livello superiore a 0. Si consiglia tuttavia di non interrompere la ricalibratura, ma di lasciarla terminare regolarmente, una volta trascorsi più di 15 secondi dal suo inizio.

By setting all channels to 0 (blackout), after an interval of about 5 seconds, all effects (except the dimmer which remains closed) are re-calibrated. It is then possible, from the control unit, to reset any motorized effects that during operation had accidentally "lost step".

The entire re-calibration cycle lasts approximately 40 seconds and can be stopped at any time by simply setting a channel at a level above 0. It is recommended not to interrupt re-calibration, but to let it end regularly, once 15 seconds have elapsed from its start.

En sélectionnant tous les canaux au niveau 0 (blackout), après un intervalle d'environ 5 secondes, une procédure de réglage des effets débute (tous les effets sauf le gradateur, qui reste fermé). Grâce à cette procédure, il est possible, depuis l'unité de commande, de reporter en position correcte d'éventuels effets motorisés qui ont "perdu la synchronisation" pendant le fonctionnement.

Le cycle de réglage complet dure environ 40 secondes et il peut être interrompu à tout moment en sélectionnant un canal de niveau supérieur à 0. supérieur à 0. Il est conseillé de ne pas interrompre le calibrage, mais de le laisser finir régulièrement, lorsque plus de 15 secondes se sont écoulées depuis le début de la procédure relative.

Stellt man alle Kanäle auf das Niveau 0 (blackout), beginnt nach etwa 5 Sekunden ein Nachkalibrierungszyklus der Effekte (alle, ausgenommen der des Dimmers, der geschlossen bleibt), dank welcher es möglich ist, von der Steuereinheit aus die motorisierten Effekte, die im Betrieb eventuell ihren „Rhythmus“ verloren haben, in ihre korrekte Position zurückzustellen.

Der gesamte Nachkalibrierungszyklus dauert etwa 40 Sekunden und kann in jedem Moment ganz einfach unterbrochen werden, indem ein Kanal über 0 eingestellt wird. Nach Ablauf von mehr als 15 Sekunden nach Beginn des Vorgangs sollte die Nachkalibrierung jedoch möglichst nicht unterbrochen, sondern ordnungsgemäß zu Ende geführt werden.

Configurando todas los canales en nivel 0 (blackout), después de un intervalo aproximado de 5 segundos, inicia un ciclo de recalibración de los efectos (todos a excepción del obscurecedor que permanece cerrado) gracias al cual es posible, por medio de la central de mando, restablecer la correcta posición de posibles efectos motorizados que durante el funcionamiento se hubieran "desajustado".

El ciclo de recalibración dura unos 40 segundos y puede interrumpirse en cualquier momento, simplemente definiendo un canal en un nivel superior a 0. Se aconseja no interrumpirlo, y esperar a que termine regularmente, si han pasado más de 15 segundos desde su inicio.