



PROFESSIONAL SHOW LIGHTING

SHADOW

QS-ST HMI 1200
 QS-LT HMI 1200
 Basic HMI 1200
 Basic HMI 575

INSTRUCTION MANUAL

IMPORTANT: Read carefully. It is essential for the correct and safe use of the equipment that erectors and operators should be fully conversant with the information and instructions given in this manual.

1 INSTALLING THE PROJECTOR

• Unpacking

Open the wooden box, remove the projector from the packing and place it on a flat horizontal surface. Unpack the standard accessories supplied with the equipment. Inspect the lamp change label (1) on the projector cover and replace it with one of the optional language versions if necessary.

Make certain that the label is never removed, as it displays important safety information.

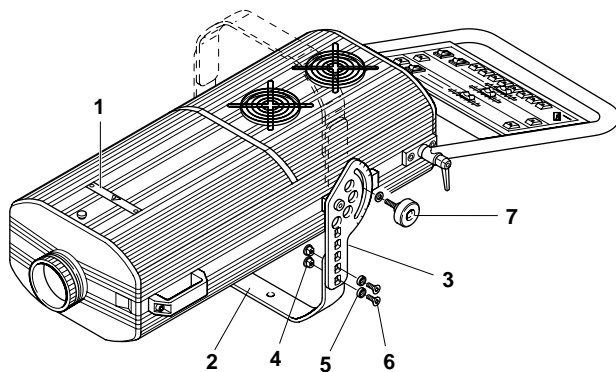

• Initial assembly operations

Position the bracket (2) on the graduated plate (3) at the desired height, select the required hole and insert the bushing (4), the chamfered washer (5) and the screw (6) and tighten the assembly using the supplied Allen wrench.

The bracket can also be mounted on the top of the projector for truss mounting by inverting the position of the graduated plate (3).

Position the support as desired and then secure it by tightening the knobs (7).

• Fitting the lamp

Refer to directions for replacement of the lamp given under heading 8 MAINTENANCE.

• Installing the projector

The projector can be mounted in any position without its operating characteristics being affected.

IMPORTANT: for ceiling installation secure the projector in the desired position by means of the holes in the support. Secure preferably using two $\varnothing 12$ mm bolts with nuts and lock washers.

Make certain that the anchorage is stable before positioning the projector.

• Minimum distance from target objects

The projector must be positioned in such a way that objects struck by the beam are separated from the fixture by at least the distance specified on the lamp change sticker next to the symbol shown in the figure on the right.

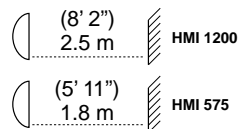

• Minimum distance of inflammable materials from any part of the fixture: 0.10 m (4") for QS and HMI 1200 Basic versions, 0.07 m (3") for HMI 575 Basic version.

F The fixture may be mounted on surfaces rated normally inflammable.

IMPORTANT: For better and more reliable operation of the projector, the ambient temperature must not exceed 35° C (95° F). Protection factor IP 20: the fixture is protected against penetration of solid bodies more than 12 mm (0.5") in diameter (first digit 2), but can be damaged by spray, jet, drip or rain water (second digit 0).

2 POWER SUPPLY AND INTERFACE

• Connecting to the electrical power supply

The operations described in this heading must be carried out by a licensed electrician.

It is good policy to connect projectors to the power supply by way of dedicated switches, so that each can be turned on and off individually from a remote station.

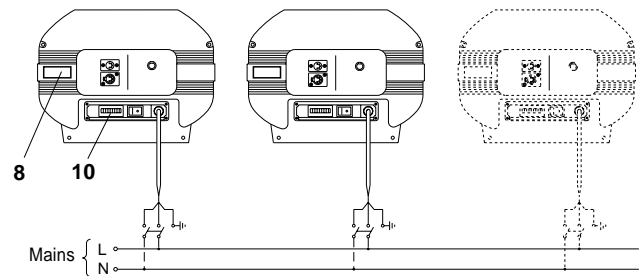

The projector is designed to operate at the voltage and frequency indicated on the electrical data plate (8) affixed to the rear end. Check that these two values correspond to the mains voltage and frequency.

IMPORTANT: the projector must be connected to a power supply circuit having a proper earth system (Class I appliance).

• Connecting the control signals

SHADOW BASIC followspots can be controlled only from the integrated control panel, while SHADOW QS models can also be controlled from a remote external controller.

0-10V CONNECTION

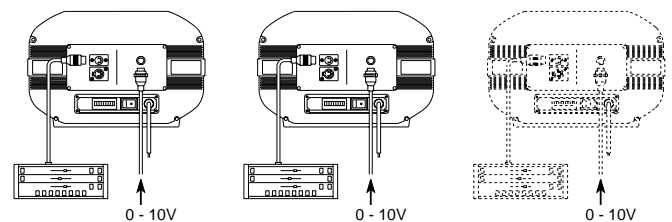

When both the external 0-10V controller and the integrated control panel are connected, the higher level signal assumes priority.

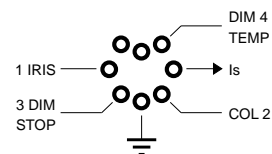

The connection between projector and controller must be made using a multicore cable with 8 wires of 0.25mm² section and a DIN 8 pin 45° plug/socket connector.

RS 232/423(PMX) - DMX 512 CONNECTION

- Several Shadow followspots can be controlled simultaneously from the integrated control panel on one fixture.

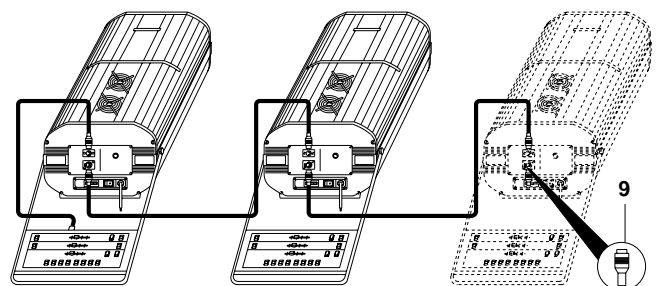

- When connected to an external controller, several projectors can be controlled either simultaneously or independently.

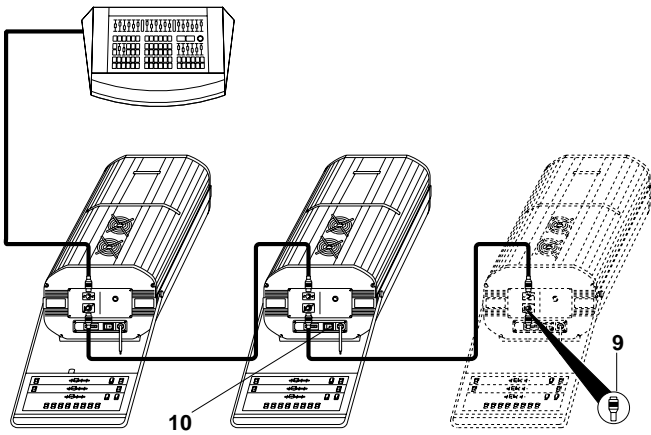

To enable independent operation of several Shadow projectors each must be assigned a unique address code. This procedure calls for the presence of an authorized technician.

Projectors are wired up to the controller and one to the next using two-core screened cable and Cannon 5 pin XLR type plug/socket connectors.

To connect a DMX line, a terminating plug (9) with a 100 Ω resistor wired between pins 2 and 3 must be fitted to the last projector connected in series; the plug is not required when using an RS232/423(PMX) signal.

The wires must not come into contact with each other or with the metal casing of the plug.

The casing of the plug/socket must be connected to the screen and to pin 1 of the connectors.

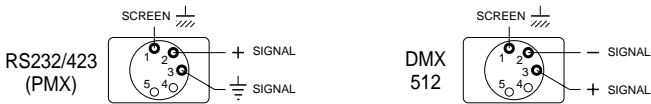

Having completed the operations described above, press the on/off switch (10). Check that the lamp comes on and that the auto-reset sequence starts.

3 CHANNELS FUNCTION (SHADOW QS)

CHANNEL	FUNCTION
1	IRIS
2	COLOUR WHEEL
3	DIMMER/STOPPER/ STROBE
4	COLOUR TEMPERATURE CONVERSION

• IRIS - channel 1

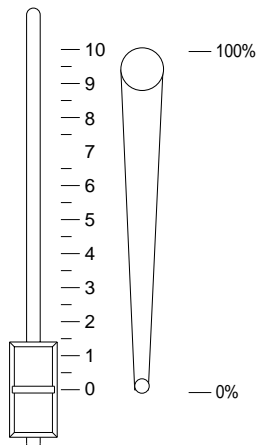

The response of the iris to the movement of the potentiometer is linear and continuous through the full 0... 100% range, so that the slider can be stopped in any position to obtain the desired aperture diameter.

• COLOUR WHEEL - channel 2

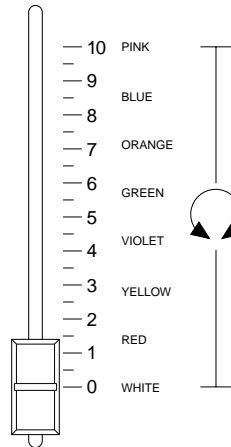

The change of colour in response to movement of the potentiometer is linear and continuous, so that the slider can be stopped in intermediate positions to obtain a two colour beam.

• DIMMER/STOPPER/STROBE - channel 3

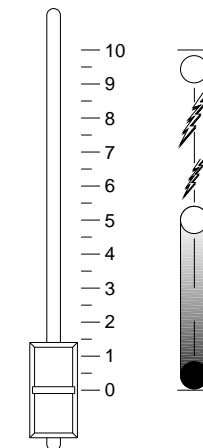

In the 0% to 50% range of adjustment the dimmer opens gradually to maximum aperture. Strobe effect is produced from 54.7% to 95% with frequency increasing from 1 to 7 flashes/second. The aperture remains fixed from 95% to 100% of the slider range.

• COLOUR TEMPERATURE CONVERSION - channel 4

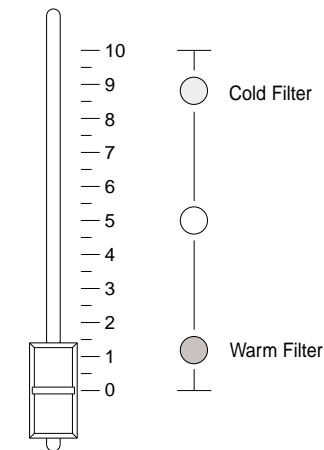

The warm filter is inserted from 0% to 33.2% of slider movement, no filter is present from 33.7% to 67.0%, and the cool filter is inserted from 67.5% to 100% of slider movement.

4 FOCUSING

• Focusing - QS-ST version

Set up the channels as shown in the table. Unscrew knob (11) and move the lens (12) forwards and back until the projected image is perfectly sharp. Secure the lens by tightening knob (11).

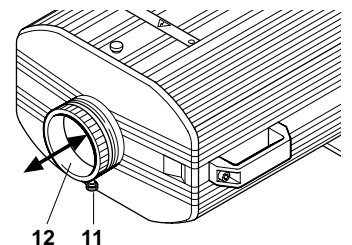

CHANNEL	FUNCTION	POSITION
1	IRIS	100% (Maximum aperture)
2	COLOUR WHEEL	0% (White)
3	DIMMER/STOPPER/ STROBE	100% (Open)
4	COLOUR TEMPERATURE CONVERSION	0% (White)

• Focusing - QS-LT version

Turn knob (13) on the rear of the projector until the projected image is perfectly sharp; this procedure can be checked by means of the pointer (14) which provides an indication of the focusing distance as shown on label (15).

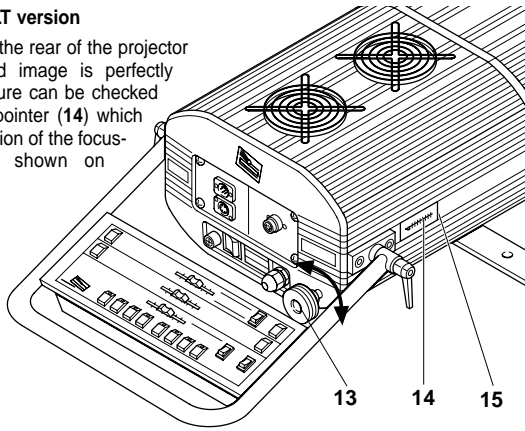

5 QS CONTROL PANEL

The controls are on the dedicated panel which can be tilted downwards through an angle of 90° starting from a position on the same axis as the projector body.

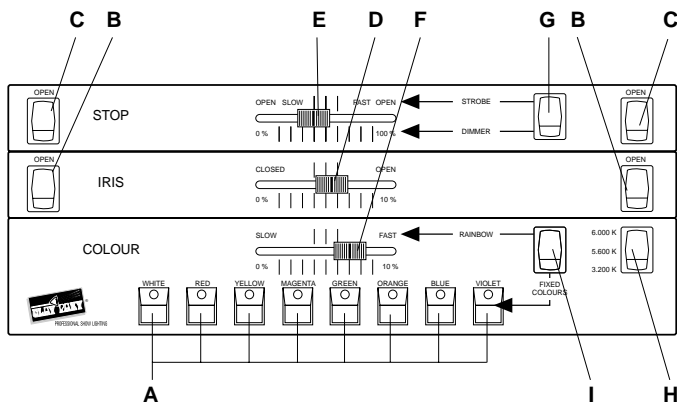

KEY

- A) 8 push buttons with indicator lights for insertion of fixed colours with two-colour beam function by pressing two adjacent buttons simultaneously;
- B) 2 flash buttons for instant iris opening;
- C) 2 flash buttons for instant stopper opening;
- D) 1 potentiometer for iris aperture adjustment;
- E) 1 potentiometer for adjusting the dimmer aperture or strobe frequency;
- F) 1 potentiometer for adjusting the rotation speed of the colour wheel (with selector I set to rainbow);
- G) 1 dimmer or strobe selector;
- H) 1 colour temperature conversion selector;
- I) 1 rainbow effect or fixed colour selector.

6 BASIC CONTROL PANEL

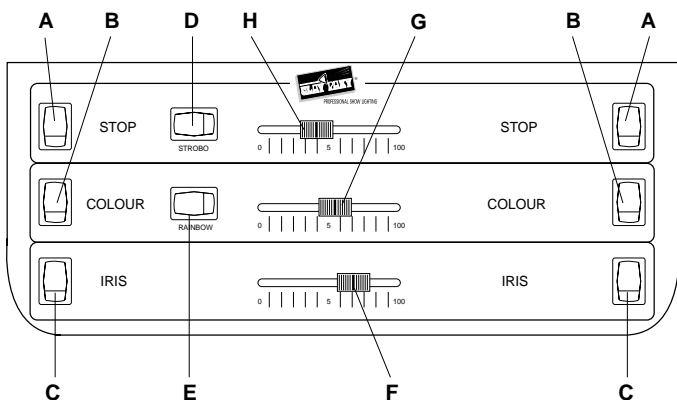

KEY

- A) 2 flash buttons for instant stopper opening;
- B) 2 flash buttons for instant rainbow effect;
- C) 2 flash buttons for instant iris opening;
- D) 1 selector for dimmer or strobe effect;
- E) 1 selector for rainbow effect or fixed colours;
- F) 1 potentiometer for iris aperture adjustment;
- G) 1 potentiometer for rainbow speed adjustment or selection of fixed colour;
- H) 1 potentiometer for dimmer aperture adjustment or strobe frequency.

7

LENS UNITS

GRAPHS SHOWING BEAM DATA AND ILLUMINATION VALUES

QS-ST / BASIC - Standard objective

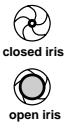
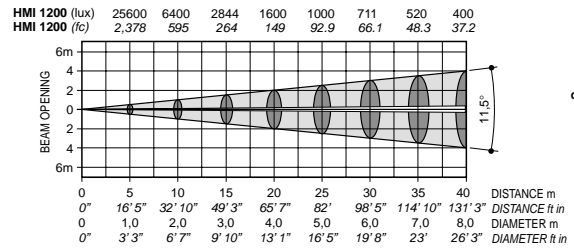

QS-ST / BASIC - Wideangle objective

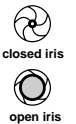
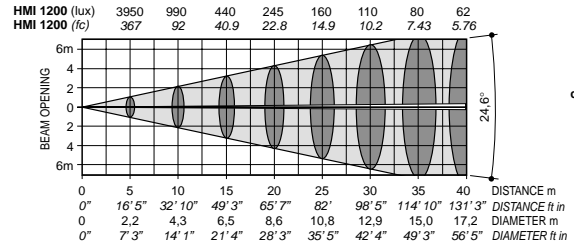

QS-LT - Standard objective

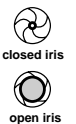
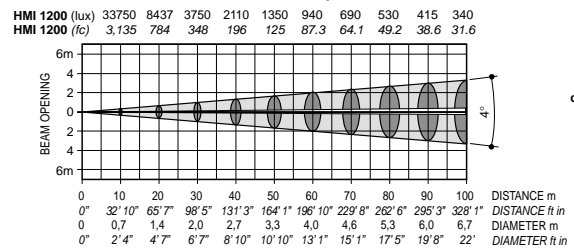

QS-LT - Wideangle objective

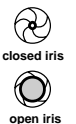
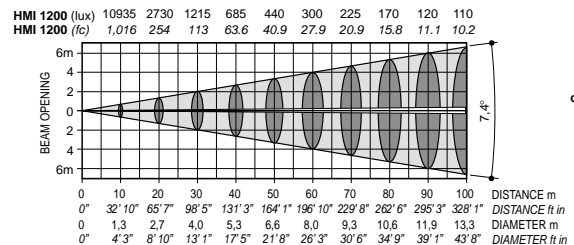

8

MAINTENANCE

IMPORTANT: isolate the projector from the electrical power supply before commencing maintenance work of any description.

The maximum temperature on the outer surface of the projector under normal operating conditions is 90°C (194°F) for QS and Basic HMI 1200 versions, and 80°C (176°F) for the Basic HMI 575 version.

After switching off, do not remove any part of the projector for at least 10 minutes, as indicated on the lamp change label (1).

Once this time has elapsed, the risk of a lamp exploding is practically zero. If the lamp needs changing, wait a further 20 minutes to avoid the risk of burns. In the event of a lamp exploding, the projector is designed to prevent fragments of glass from being scattered. The lenses supplied with the projector must be fitted at all times, and if visibly damaged must be replaced promptly with genuine spares.

• Opening the projector

Loosen knob (16) to remove the lamp access cover (17) or loosen knob (18) to remove the front cover (19). Once the necessary work has been completed, refit the cover and tighten with the relative knob.

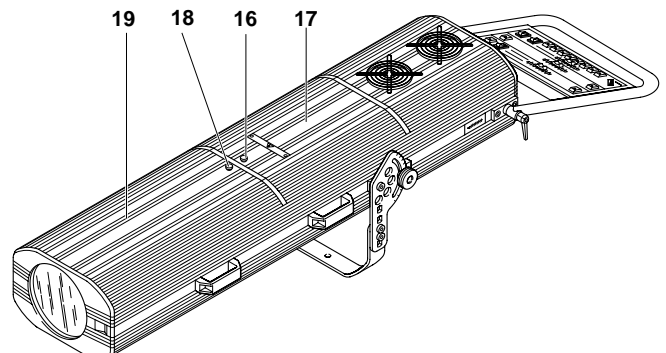

• **Changing the lamp**

Open the projector, loosen the two side nuts (20) of the lamp to be changed and remove it from the supports (21). Remove the new lamp from its box, loosen the two side nuts (20) and locate the lamp in the supports (21). Finally, retighten the nuts.

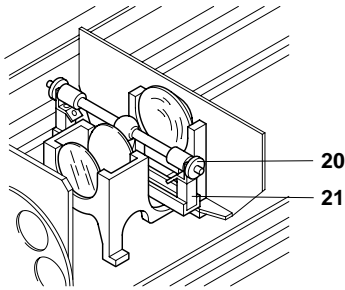

IMPORTANT: for uniform distribution of the light beam, the lamp must be positioned so that the glass pip (22) on the bulb does not coincide with the optical axis of the projector. With this in mind, locate the pip as high up as possible.

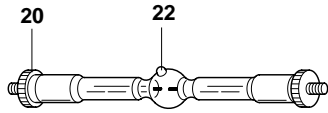

CAUTION: The projector uses a high pressure lamp with external starter.

- When fitting a new lamp, read the manufacturer's instructions carefully.
- The lamp must always be changed without delay if damaged or deformed by heat.

• **Changing the colour filters**

Having opened the projector, identify the filter to be changed, grip firmly between thumb and forefinger and push against the spring clip (23) until free of the fixed clips (24). Bend the filter outwards and remove.

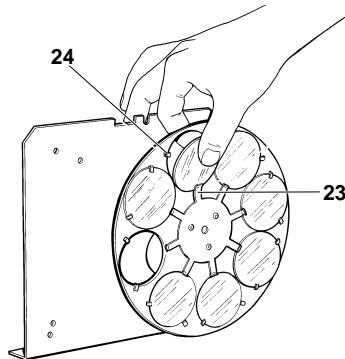

Offer the new filter to the spring clip (23) and anchor behind the two fixed clips (24).

• **Installing wide angle lenses**

Remove the projector front cover. Unscrew knobs (25), rotate the front lens plate (26) from the parking position to the operating position in alignment with the projector axis and then perform the same operation with the rear lens plate (27).

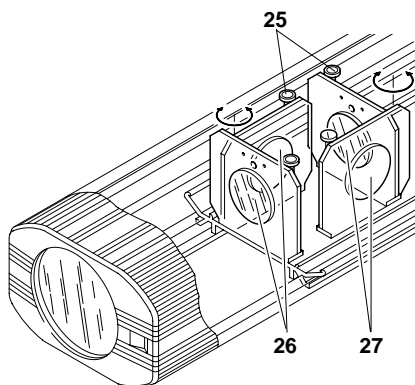

Refit the knobs and secure the two lens plates.

• **Lubrication of sliding contact parts - QS LT**

To ensure perfect operation of sliding contact parts of the projector, lubricate sparingly at 6-monthly intervals using Kernite Lube-K-AC grease.

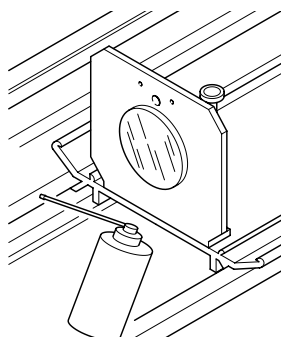

• **Routine cleaning**

To maintain the light output of the projector undiminished, parts that tend to accumulate dust and grease must be cleaned periodically. In most circumstances, the projector will give long and trouble-free service if these simple guidelines are followed. To remove dirt from the lenses and filters, use a soft cloth moistened with any liquid detergent suitable for cleaning glass.

IMPORTANT: do not use solvents or alcohol

- Parts that need cleaning frequently.
- Parts that need cleaning monthly.

Internal components should also be given a general clean once a year, dislodging dust and dirt with a brush and removing it simultaneously with a vacuum cleaner.

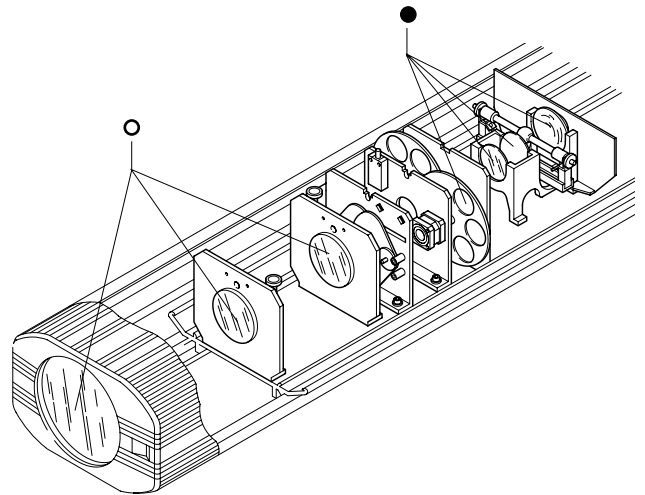

9 TROUBLESHOOTING

PROJECTOR DOES NOT LIGHT UP		ANOMALIES
ELECTRONICS NOT WORKING		
PROJECTION FAULTY FAULTS		
REDUCED BRIGHTNESS		
	POSSIBLE CAUSES	CHECKS AND REMEDIES
●	No electrical power supply.	Check that power is available at the mains socket.
●	Lamp expended or faulty.	Change lamp (see instructions).
●	Signal transmission cable short-circuiting or disconnected.	Change cables.
●	Address codes incorrect.	See projector coding instructions.
●	Defect in electronic circuits.	Contact an authorized technician.
●	Lenses broken.	Contact an authorized technician.
●	Deposit of dust or grease.	Clean (see instructions).

ELECTRICAL MECHANICAL SPECIFICATIONS

Power supply

- 220 - 240V 50Hz
- 200 - 220V 60Hz

Lamp

Metal halide with special built-in power supply.

- Type: HMI 1200W
 - Cap: SFc 15.5-6
 - Colour temperature: 6000 K
 - Luminous flux: 110000 lm
 - Average life: 750 h
- Type: HMI 575W
 - Cap: SFc 10-4
 - Colour temperature: 6000 K
 - Luminous flux: 49000 lm
 - Average life: 750 h

Power consumption

- QS-ST/LT HMI 1200: 1500VA at 230V 50Hz
- BASIC HMI 1200: 3000VA at 230V 50Hz
- BASIC HMI 575: 1500VA at 230V 50Hz

Motors

N. 4 (BASIC) N. 5 (QS) microstepping motors with full microprocessor control.

OPTICAL SYSTEM

Main optical unit

- Base in diecast aluminium.
- Twin lens condenser.
- High luminous efficiency spherical reflector.

Lens unit

QS-ST and BASIC

- Standard: 1:2.5/250mm
- Optional: wide angle for insertion inside the projector.

QS-LT

Special optics with wide angle lens as standard (manual insertion).

CONTROL SYSTEMS

Channels

- N. 3 control channels (BASIC)
- N. 4 control channels (QS)

Inputs

SHADOW QS is set up to accept analog or digital signals from controllers or computers:

- Digital serial input RS232/423(PMX) or DMX512
- 0-10V analog input

CONSTRUCTION FEATURES

Safety devices

- Power shuts off automatically in the event of overheating or cooling system failure.
- Power shuts off automatically when cover is opened.

Cooling

Forced ventilation cooling system using axial flow fans.

Housing

- Extruded diecast aluminium.
- Epoxy powder coated finish.

Mounting

- Steel bracket with epoxy powder coated finish.
- Six installation positions, 25 mm apart.
- Bracket adjustable through 100° with graduated scale for position finding.

Operating position

Will function in any position.

Weights and Dimensions

- QS-ST HMI 1200: 38 kg (83 lbs 10 ozs)
- QS-LT HMI 1200: 49 kg (107 lbs 13 ozs)
- Basic HMI 1200: 38 kg (83 lbs 10 ozs)
- Basic HMI 575: 30 kg (66 lbs)

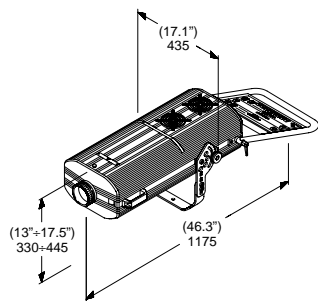

SHADOW Basic HMI 575
SHADOW Basic HMI 1200
SHADOW QS ST HMI 1200

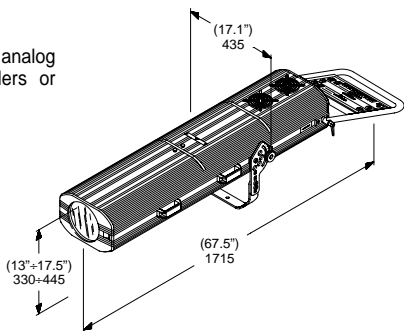

SHADOW QS-LT HMI 1200

BASIC

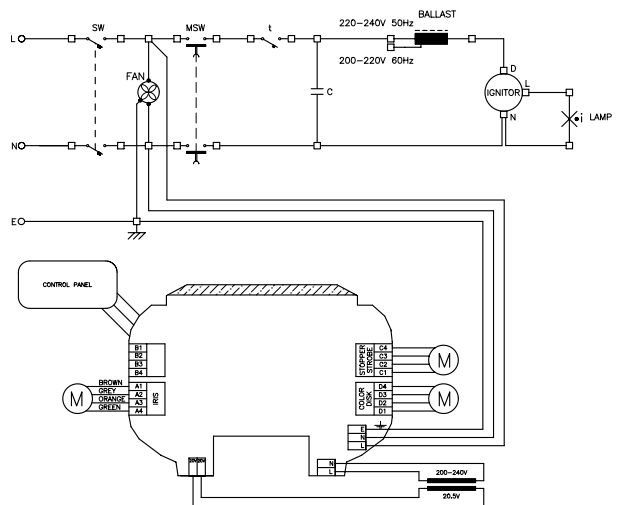

QS-ST - QS-LT

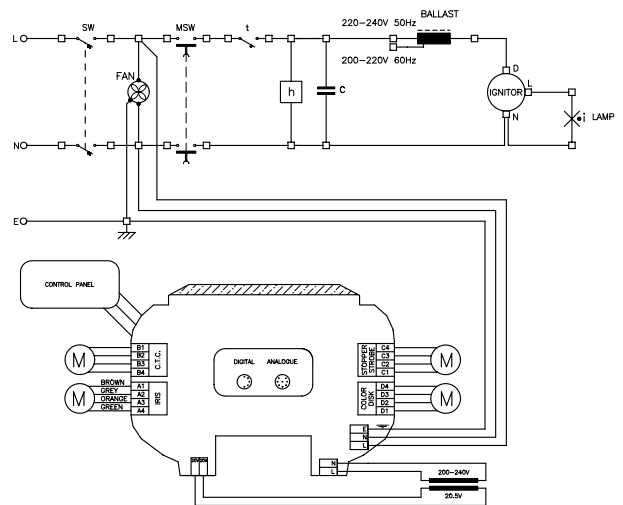

The specifications published in this manual are not binding, and may be revised or updated at any time by Clay Paky without notice in the interests of improving product quality.



The products referred to in this manual comply with EC Directives on:

- Low Voltage 73/23
- Electromagnetic Compatibility 89/336