

ALPHA WASH HALO 1200

CHANNEL	Dmx MODALITY		
	Option Stnd	Option 16 b	Option Extn
1	CYAN <input type="text" value="C"/> <input type="text" value="y"/> <input type="text" value="a"/> <input type="text" value="n"/>	CYAN <input type="text" value="C"/> <input type="text" value="y"/> <input type="text" value="a"/> <input type="text" value="n"/>	CYAN <input type="text" value="C"/> <input type="text" value="y"/> <input type="text" value="a"/> <input type="text" value="n"/>
2	MAGENTA <input type="text" value="M"/> <input type="text" value="g"/> <input type="text" value="n"/> <input type="text" value="t"/>	MAGENTA <input type="text" value="M"/> <input type="text" value="g"/> <input type="text" value="n"/> <input type="text" value="t"/>	MAGENTA <input type="text" value="M"/> <input type="text" value="g"/> <input type="text" value="n"/> <input type="text" value="t"/>
3	YELLOW <input type="text" value="Y"/> <input type="text" value="e"/> <input type="text" value="l"/> <input type="text" value="w"/>	YELLOW <input type="text" value="Y"/> <input type="text" value="e"/> <input type="text" value="l"/> <input type="text" value="w"/>	YELLOW <input type="text" value="Y"/> <input type="text" value="e"/> <input type="text" value="l"/> <input type="text" value="w"/>
4	STOPPER/STROBE <input type="text" value="S"/> <input type="text" value="h"/> <input type="text" value="u"/> <input type="text" value="t"/>	STOPPER/STROBE <input type="text" value="S"/> <input type="text" value="h"/> <input type="text" value="u"/> <input type="text" value="t"/>	STOPPER/STROBE <input type="text" value="S"/> <input type="text" value="h"/> <input type="text" value="u"/> <input type="text" value="t"/>
5	DIMMER LAMP <input type="text" value="D"/> <input type="text" value="i"/> <input type="text" value="m"/> <input type="text" value="r"/>	DIMMER LAMP <input type="text" value="D"/> <input type="text" value="i"/> <input type="text" value="m"/> <input type="text" value="r"/>	DIMMER LAMP <input type="text" value="D"/> <input type="text" value="i"/> <input type="text" value="m"/> <input type="text" value="r"/>
6	FROST <input type="text" value="F"/> <input type="text" value="r"/> <input type="text" value="s"/> <input type="text" value="t"/>	FROST <input type="text" value="F"/> <input type="text" value="r"/> <input type="text" value="s"/> <input type="text" value="t"/>	FROST <input type="text" value="F"/> <input type="text" value="r"/> <input type="text" value="s"/> <input type="text" value="t"/>
7	OVALIZER <input type="text" value="O"/> <input type="text" value="v"/> <input type="text" value="a"/> <input type="text" value="l"/>	OVALIZER <input type="text" value="O"/> <input type="text" value="v"/> <input type="text" value="a"/> <input type="text" value="l"/>	OVALIZER <input type="text" value="O"/> <input type="text" value="v"/> <input type="text" value="a"/> <input type="text" value="l"/>
8	ZOOM <input type="text" value="Z"/> <input type="text" value="o"/> <input type="text" value="o"/> <input type="text" value="m"/>	ZOOM <input type="text" value="Z"/> <input type="text" value="o"/> <input type="text" value="o"/> <input type="text" value="m"/>	ZOOM <input type="text" value="Z"/> <input type="text" value="o"/> <input type="text" value="o"/> <input type="text" value="m"/>
9	PAN <input type="text" value="P"/> <input type="text" value="a"/> <input type="text" value="n"/>	PAN <input type="text" value="P"/> <input type="text" value="a"/> <input type="text" value="n"/>	PAN <input type="text" value="P"/> <input type="text" value="a"/> <input type="text" value="n"/>
10	TILT <input type="text" value="T"/> <input type="text" value="i"/> <input type="text" value="l"/> <input type="text" value="t"/>	TILT <input type="text" value="T"/> <input type="text" value="i"/> <input type="text" value="l"/> <input type="text" value="t"/>	PAN-FINE
11	RESET	RESET	TILT <input type="text" value="T"/> <input type="text" value="i"/> <input type="text" value="l"/> <input type="text" value="t"/>
12	PAN - TILT TIME (with option Vect ON)	PAN FINE	TILT FINE
13	COLOUR TIME (with option Vect ON)	TILT FINE	RESET
14	BEAM TIME (with option Vect ON)	PAN - TILT TIME (with option Vect ON)	PAN - TILT TIME (with option Vect ON)
15	BEAM SHAPE TIME (with option Vect ON)	COLOUR TIME (with option Vect ON)	COLOUR TIME (with option Vect ON)
16		BEAM TIME (with option Vect ON)	BEAM TIME (with option Vect ON)
17		BEAM SHAPE TIME (with option Vect ON)	BEAM SHAPE TIME (with option Vect ON)

• COLOUR MIXING - channel 1 - 2 - 3

Operation with option *CMY Off*



BIT	%	EFFECT
255	100	COLOUR EXCLUDED
0	0.0	COLOUR INSERTED

IMPORTANT: The lamp dim to half power 3 seconds after the channels 1-2-3 stay at 0% level. The lamp goes back to full power when the channel level is put higher than 0%.

Operation with option *CMY On*

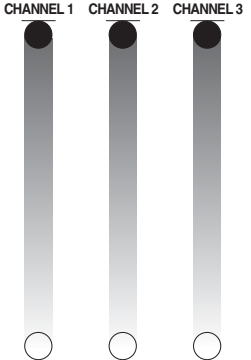

BIT	%	EFFECT
255	100	COLOUR INSERTED
0	0.0	COLOUR EXCLUDED

IMPORTANT: The lamp dim to half power 3 seconds after the channels 1-2-3 stay at 100% level. The lamp goes back to full power when the channel level is put lower than 100%.

• STOPPER / STROBE - channel 4



BIT	%	EFFECT
252 - 255	98.7 - 100	OPEN
239 - 251	93.7 - 98.2	RANDOM FAST STROBE
226 - 238	88.7 - 93.2	RANDOM MEDIUM STROBE
213 - 225	83.7 - 88.2	RANDOM SLOW STROBE
208 - 212	81.7 - 83.2	OPEN
207	81.2	FAST PULSATION
108	42.5	SLOW PULSATION
104 - 107	41.0 - 42.0	OPEN
103	40.5	FAST STROBE (12 flash/sec)
4	1.7	SLOW STROBE (1 flash/sec)
0 - 3	0.0 - 1.2	CLOSED

IMPORTANT: The lamp dim to half power 3 seconds after the channel stay at 0% level. The lamp goes back to full power when the channel level is put higher than 0%.

• DIMMER LAMP - channel 5



BIT	%	EFFECT
255	100	LAMP ON
0	0.0	LAMP OFF

• FROST - channel 6



BIT	%	EFFECT
255	100	FROST INSERTED
0	0.0	FROST EXCLUDED

• OVALIZER - channel 7



BIT	%	EFFECT
255	100	OVAL INSERTED
0	0.0	OVAL EXCLUDED

• ZOOM - channel 8



BIT	%	EFFECT
255	100	WIDE BEAM
0	0.0	NARROW BEAM

• PAN - channel 9

Operation with option *Pan* \diamond Off

(Tilt conventionally represented at 15% and option *Tilt* \diamond Off)

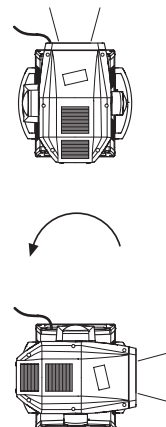

BIT	%
255	100
0	0.0

Operation with option Pan \diamond On
(Tilt conventionally represented at 15% and option Tilt \diamond Off)

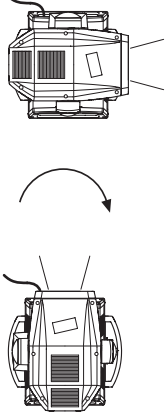

BIT	%
255	100
0	0.0

• PAN FINE - channel: 12 (16 b) - 10 (Extn)

Operation with option Pan \diamond Off
(Tilt conventionally represented at 15% and option Tilt \diamond Off)

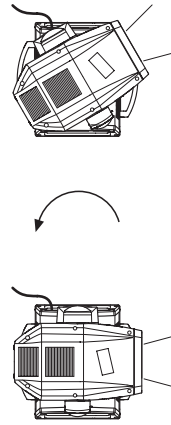

BIT	%
255	100
0	0.0

• TILT - channel: 10 (Std, 16b) - 11 (Extn)

Operation with option Tilt \diamond Off
(Pan conventionally represented at 0% and option Pan \diamond Off)

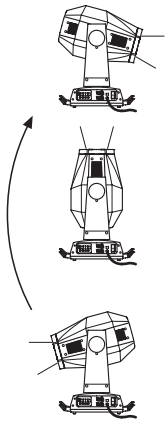

BIT	%
255	100
128	50.0
0	0.0

Operation with option Pan \diamond On
(Tilt conventionally represented at 15% and option Tilt \diamond Off)

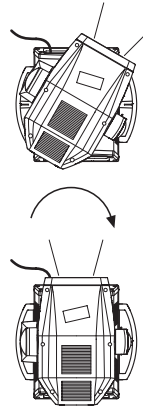

BIT	%
255	100
0	0.0

Operation with option Tilt \diamond On
(Pan conventionally represented at 0% and option Pan \diamond Off)

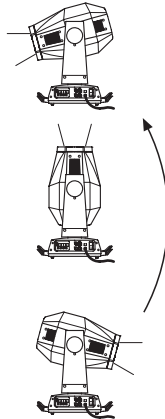

BIT	%
255	100
128	50.0
0	0.0

• TILT FINE - channel: 13 (16 b) - 12 (Extn)

Operation with option Tilt \diamond Off
(Pan conventionally represented at 0% and option Pan \diamond Off)



BIT	%
255	100
0	0.0

• RESET - channel: 11 (Std, 16b) - 13 (Extn)

BIT	%	EFFECT
255	100	COMPLETE RESET
		Complete reset is activated passing through the unused range and staying 5 seconds in complete reset levels.
128	50.0	COMPLETE RESET
127	49.7	PAN / TILT RESET
		Pan / Tilt reset is activated passing through the unused range and staying 5 seconds in Pan / Tilt reset levels.
77	30.0	PAN / TILT RESET
76	29.7	EFFECTS RESET
		Effects reset is activated passing through the unused range and staying 5 seconds in Effects reset levels.
26	10.0	EFFECTS RESET
25	9.7	
0	0.0	UNUSED RANGE

Operation with option Tilt \diamond On
(Pan conventionally represented at 0% and option Pan \diamond Off)

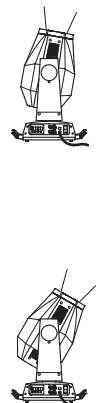

BIT	%
255	100
0	0.0

TIMING CHANNELS

Timing Channel	Channel function
Pan - Tilt time	Pan - Tilt - (Pan fine - Tilt fine)
Colour time	CMY
Beam time	Zoom - Frost
Beam shape time	Ovalizer

TIME TABLE

BIT	Seconds	BIT	Seconds	BIT	Seconds	BIT	Seconds	BIT	Seconds	BIT	Seconds
0	Full	43	8.6	86		129		172		216	
1	0.2	44	8.8	87	24	130	41	173	58	217	170
2	0.4	45	9	88		131		174		218	
3	0.6	46	9.2	89	25	132	42	175	59	219	180
4	0.8	47	9.4	90		133		176		220	
5	1	48	9.6	91	26	134	43	177	60	221	190
6	1.2	49	9.8	92		135		178		222	
7	1.4	50	10	93	27	136	44	179	65	223	200
8	1.6	51	10.2	94		137		180		224	
9	1.8	52	10.4	95	28	138	45	181	70	225	210
10	2	53	10.6	96		139		182		226	
11	2.2	54	11	97	29	140	46	183	75	227	220
12	2.4	55	12	98		141		184		228	
13	2.6	56	13	99	30	142	47	185	80	229	230
14	2.8	57	14	100		143		186		230	
15	3	58	15	101	31	144	48	187	85	231	240
16	3.2	59	16	102		145		188		232	
17	3.4	60	17	103	32	146	49	189	90	233	250
18	3.6	61	18	104		147		190		234	
19	3.8	62	19	105	33	148	50	191	95	235	260
20	4	63	20	106		149		192		236	
21	4.2	64	21	107	34	150	51	193	100	237	270
22	4.4	65	22	108		151		194		238	
23	4.6	66	23	109	35	152	52	195	110	239	280
24	4.8	67	24	110		153		196		240	
25	5	68	25	111	36	154	53	197	120	241	290
26	5.2	69	26	112		155		198		242	
27	5.4	70	27	113	37	156	54	199	130	243	300
28	5.6	71	28	114		157		200		244	
29	5.8	72	29	115	38	158	55	201	140	245	280
30	6	73	30	116		159		202		246	
31	6.2	74	31	117	39	160	56	203	150	247	290
32	6.4	75	32	118		161		204		248	
33	6.6	76	33	119	40	162	57	205	160	249	300
34	6.8	77	34	120		163		206		250	
35	7	78	35	121	41	164	58	207	170	251	310
36	7.2	79	36	122		165		208		252	
37	7.4	80	37	123	42	166	59	209	180	253	310
38	7.6	81	38	124		167		210		254	
39	7.8	82	39	125	43	168	60	211	190	255	Follow cue Data
40	8	83	40	126		169		212			
41	8.2	84	41	127	44	170	61	213	200		
42	8.4	85	42	128		171		214			
								215	210		